



haskell
EDUCATION
Learn. Think. Do.™

Price List

February 2023

2.8.23



<https://www.haskelleducation.com>

Lifetime Guarantee

The following limited Lifetime Guarantee applies to all Haskell products:

Haskell guarantees, to the Original Purchaser of this Haskell furniture, all parts to be free from defects in material and workmanship; and as long as the Original Purchaser owns this furniture, we will replace any metal part or parts thereof which our examination discloses to be defective, provided no unauthorized corrective action has been taken prior to such examination. Please note, this guarantee does not apply to product misuse, abuse, or alteration. We do not cover damage caused by accident, fire, flood or act of God.

Exceptions to the Haskell Lifetime Guarantee

Ethos Series – 12 years on casters, glides, pneumatic cylinders, tablets and tablet support arms.

Echo™ Series – marker board laminates are subject to manufacturer's published warranty.

Explorer Series® – 12 years on casters and pneumatic cylinders.

Fuzion™ Sit Stand Series – 12 years on casters, glides, and adjust mechanism. 20 years on hydraulic cylinder.

Contents

alphabetical

General Information	5	Explorer Series®	
Finish Guide	7	Rover® Table	68
360 Series		Explorer Series® Maker Table	74
360 Series Chair	11	Explorer Series® Cargo Cart	86
360 Series Stool	14	Explorer Series® Storage Carts	96
		Explorer Series® Think Nook™	100
Assemble Series		Fuzion™ Series	
Assemble Series Conferencing & Multi-Purpose	19	Fuzion™ Series Sit to Stand Desk	102
Assemble Series Training Tables	20	Fuzion™ Series Teacher's Lectern with Storage ...	104
		Fuzion™ Series Teacher's Desk	105
Captiva™ Series		Marathon Series	
Captiva™ Series Pedestals	23	Marathon Series Desking & Storage	110
Captiva™ Series Lateral Files	27	Marathon Series Seating	118
Captiva™ Series Wardrobe & Storage Cabinets	28		
Captiva™ Series Vertical Files	34	Market Series	
Captiva™ Series Bookcases	37	Market Series Pedestals	122
		Market Series Lateral Files	125
Disco Series		Market Series Wardrobe & Storage Cabinets	127
Disco Series Stool	40	Market Series Vertical Files	135
		Market Series Bookcases	138
Echo™ Series		Market Series Desking	141
Echo™ Series Instruction Zone	43	Market Series Instruction Zone	151
Echo™ Series Individual Student Desk	44		
Echo™ Series Training & Teaming Tables	47	Smart Series	
Echo™ Half Round Training Table	50	Smart Series Desking	154
Echo™ Series Meeting Tables	54	Smart Series Instruction Zone	164
Echo™ Series Easel, Marker Boards and Rails	56		
		Voyager Series	
Ethos Series		Voyager Series Tables	168
Ethos Series Storage Base	61	Voyager Series Storage Carts	172
Ethos Series Five Star Base	63		
Ethos Series Stool Height	64		

Contents

by type

General Information	5
Finish Guide	7
Filing & Storage	
Market Series Pedestals	122
Market Series Lateral Files	125
Market Series Wardrobe & Storage Cabinets	127
Market Series Vertical Files	135
Market Series Bookcases	138
Captiva™ Series Pedestals	23
Captiva™ Series Lateral Files	27
Captiva™ Series Wardrobe & Storage Cabinets	28
Captiva™ Series Vertical Files	34
Captiva™ Series Bookcases	37
Desking	
Market Series	141
Marathon Series	110
Smart Series	154
Carts, Lecterns & Instruction Zone	
Market Series Instruction Zone	151
Smart Series Instruction Zone	164
Echo™ Series Instruction Zone	43
Echo™ Series Easel, Marker Boards and Rails	56
Explorer Series® Cargo Cart	86
Explorer Series® Storage Carts	96
Voyager Series Storage Carts	172
Explorer Series® Think Nook™	100
Makerspace	
Rover® Table	68
Explorer Series® Maker Table	74
Explorer Series® Cargo Cart	86
Explorer Series® Storage Carts	96
Explorer Series® Think Nook™	100
Tables	
Assemble Series Conferencing & Multi-Purpose	19
Assemble Series Training Tables	20
Echo™ Series Instruction Zone	43
Echo™ Series Individual Student Desk	44
Echo™ Series Training & Teaming Tables	47
Echo™ Half Round Training Table	50
Rover® Table	68
Explorer Series® Maker Table	74
Voyager Series Tables	168
Seating	
Ethos Series Storage Base	61
Ethos Series Five Star Base	63
Ethos Series Stool Height	64
Marathon Series Seating	118
Rover® Table Stool	69
Explorer Series® Think Nook™	100
Sit to Stand	
Fuzion™ Series Sit to Stand Desk	102
Fuzion™ Series Teacher's Lectern with Storage ...	104
Fuzion™ Series Teacher's Desk	105

General Information

Prices

All prices are subject to change without notice. All orders will be accepted for delivery within prevailing lead time at prices in effect at the time that the order is received by us.

Please call Customer Support for current lead times.

Lifetime Guarantee

All Haskell products are covered by the following limited Lifetime Guarantee:

Haskell guarantees, to the Original Purchaser of this Haskell furniture, all parts to be free from defects in material and workmanship; and as long as the Original Purchaser owns this furniture we will replace any metal part or parts thereof which our examination discloses to be defective, provided no unauthorized corrective action has been taken prior to such examination. Please note this guarantee does not apply to product misuse, abuse, or alteration. We do not cover damage caused by accident, fire, flood or act of God.

Exceptions to the Haskell Lifetime Guarantee

Ethos Series – 12 years on casters, glides, pneumatic cylinders, tablets and tablet support arms.

Echo™ Series – marker board laminates are subject to manufacturer's published warranty.

Custom Finish Program

Custom Paint Finish – All Haskell standard paint colors consist of a two coat electrostatic enamel process, providing a high impact and fade resistant finish. At Haskell we offer you any paint color through our paint matching program and all custom paint colors are offered in the same two coat electrostatic enamel process as our standard offering. There will be an upcharge for custom paint colors as follows:

1) For orders of 20 pieces or more, excluding accessories, add \$250 net charge per color, per order.

2) For orders of less than 20 pieces, excluding accessories, add \$500 net charge per color, per order.

Bright whites, bright colors and micas are available but are quoted on a per job basis and charges may differ from those listed above. If in question, please submit a sample to Haskell Customer Support.

Custom Plastic Finish – At Haskell we offer you any plastic color through our plastic matching program, allowing clients to customize the Ethos Series for your specific project needs. There will be quantity requirements of 300 piece and an upcharge for the plastic matching program, please contact your local sales representative for more information and pricing.

Custom Approval Process – Submit two samples for Haskell to match, we will return the matched sample for your signed approval. Please add 15-20 working days to normal lead times to allow for custom finishes. Samples should be sent to address listed below and tagged with the project name.

Haskell, LLC.
273 Montgomery Avenue
Bala Cynwyd, PA 19004

Engineering Specials (non-catalog products)

Prices for non-catalog products (any variation in size,color or other standards from our catalogued items) will be supplied upon request. Orders for non-catalog products will be accepted only with a valid quotation number appearing on the customer's order. Non-catalog products are not subject to standard lead times.

Contact Customer Support for quotation and lead time information.

Freight Damage and Claims

We carefully inspect and pack our products before we turn it over to the carrier. Everything is packaged to prevent damage in transit. We select the best carriers available who transport furniture on a regular basis. Once we give it to the carrier, we cannot be responsible for damage in shipment as the transportation company assumes complete responsibility for delivering the product to you in good condition. So, when you take delivery of the product, protect yourself by noting on the bill of lading the extent of any damage or shortage before signing it. Concealed damage should be reported to the carrier as soon as discovered—not later than 15 days from receipt of shipment. Our Customer Support staff will assist in helping you to file the claims if you so desire.

Freight

The cost of freight to the contiguous 48 states is included in the cost of the product on orders with a list price of \$22,250 or more provided that the order ships to a single address. Multiple orders shipping to one location on one day will be combined to reach the \$22,250 list price. Customers should specifically request that orders ship together if they want to combine orders for freight savings. Such a request may result in a delay until all orders are ready for shipping.

Ethos Series – free freight with 25 chairs or more.

Changes and Cancellations

Given our short lead times, cancellations or changes to product models, colors, sizes or quantities can only be accepted within the week of order entry. Please contact Customer Support to find out what options are available.

NOTE: PUT IT IN WRITING!

All changes and cancellations must be sent via fax or e-mail to ensure accurate recording of your change request. Non-catalog items or "Engineering Specials" (any product variation in size, color, or other standard from our regularly catalogued items) require 50% deposit with the order, which will be forfeited in the event of cancellation after the first week of order entry.

General Information

How to Place an Order

Provide the following information:

1. P.O. Number
2. "Bill to" and "ship to" name and address
3. Quantity
4. Complete model number
5. Brief description
6. Options (where applicable)
 - a. Special keying instructions
 - b. Paint finish (specify by name and number)
 - c. Top finish (specify by name and number)
 - d. Trim options (where applicable)
 - e. Accessories

Order Entry and Communications

All communications and orders should be directed to our offices at:

Haskell, LLC. Telephone: 800.334.8888
 273 Montgomery Avenue Facsimile: 724.265.1223
 Bala Cynwyd, PA 19004 sales@haskelloffice.com

Order Acknowledgements

All customer orders are acknowledged in writing by fax or e-mail. You can expect to receive an acknowledgment within 48 hours after entering your order. We would ask you to confirm that the acknowledgement is correct within two days. If we do not hear from you, we will advise you that production is commencing on your order as shown on your acknowledgement.

Returns

All returns must be approved and authorized in writing by Haskell Customer Support before any return can take place. In those instances where a return has been authorized, shipments will not be accepted unless accompanied by a written authorization from Haskell Customer Support Department. Merchandise must be returned in original shipping materials. A restocking fee will apply.

Storage

If you are not able to accept delivery within a week of the acknowledged ship date, we can store the product, at your expense. If Customer Support is notified in time to delay production, storage charges can be avoided. Please notify Customer Support in writing of any schedule changes immediately and they will try to accommodate your request.

GSA - U.S. General Services Administration

Contract Number: GS-27F-029DA

Contract Period: Contact your sales representative

Approved Product: Complete Line from Haskell

Federal Supply Schedule: FSC Group 71, Part 1 / Office Furniture / FSC Class 7110

Special Item Numbers (SIN): 711-1, 711-2, 711-3, 711-7, 711-8

Business Classification: Small Business

Discount: Contact your sales representative

End-User Prompt Payment Terms: 1% 20 days, net 30 days

Accepted Credit Cards: MasterCard, Visa, American Express, Discover

Maximum Order Limitation: \$500,000

Freight Program: 1-20 Units, Origin. 21+ Units, Destination

Lead Times: 4-6 weeks

Finish Guide

worksurface options: Assemble, Echo™, Fuzion™, Smart, Marathon, Market

WOOD GRAIN LAMINATE	HASKELL CODE	PATTERNED LAMINATE	HASKELL CODE
Asian Night 7949-38	NI	Casual Linen 4943-38	LC
Fusion Maple 7909-60 (HA)	H	Classic Linen 4943-38	LN
Grey Elm 8201-38	GE	Grey Nebula 4622-60	GN
Harvest Maple 7953-38	MH	Pressed Linen 4991-38	PN
Montana Walnut 7110-60 (MT)	K	Shadow Zephyr 4857-60	ZS
Natural Rift 7954-38	NA	White Tigris 4783-60	TG
Neo Walnut 7991-38	NW	SOLID LAMINATE	HASKELL CODE
Wild Cherry 7054-60 (CH)	WR	Fog 961-58 (Formica)	FF
		WRITABLE LAMINATE	HASKELL CODE
		Frosty White 949-90 (Formica) (available on Echo™ series only) consult price list for upcharge for writable surface	F9

wood grain 3mm edge options: Assemble, Echo™, Fuzion™, Smart, Marathon, Market Desking

COLOR	HASKELL CODE
Asian Night W7949	AN
Fusion Maple W7909-2009	I
Grey Elm W8201	GE
Harvest Maple W7953	MH
Montana Walnut W7110	OW
Natural Rift W7954	RT
Neo Walnut W7991	NW
Summer Flame (matches wild cherry) TL420-2009	SM

solid 3mm edge options: Assemble, Echo™, Fuzion™, Smart, Marathon, Market Desking

COLOR	HASKELL CODE
Black W1595	A
Fog F961	FG
Grey W1500	B
Orange Grove WD501	OG
Pepperdust WD327	G
Primary Yellow PTSY914	PY
Slate Grey WD91	F
Spectrum Blue F8515	SB
Spectrum Red F845	SR

paint color options: Captiva™, Smart, Marathon, Market Desking & Storage

PAINT COLOR	HASKELL CODE	PAINT COLOR	HASKELL CODE
Arctic Gray 5019	AG	Smoke 5066	SM
Black 5002	BK		
Brownstone 5064	BR		
Graphite 5925	28		
Pacifica 5083	PF		
Platinum	P2		
Platinum* 5055	PL		
Powder Beige 5025	BG		
*PL is smooth the rest are textured			

paint color options: Explorer frame color options

PAINT COLOR	HASKELL CODE
Green Apple	GA
Navy	EN
Platinum	P2

360 series

introduction



General

Designed with simplicity in mind, the 360 Chair is anything but simple. Packed into the sleek frame are a multitude of features all designed to enhance the total experience of students, teachers, and facilities staff alike. With its breadth of line, the 360 Chair meets the rigorous needs of today's learning environments while enhancing student engagement and supporting great design.

Base Options



Bookbag Rack

Optional bookbag rack allows easy access for storage of backpacks and personal items.



Heights









Color Notation

Choose colors for the chair, seat, back and optional bookbag rack.



360 Series

Chair

DESCRIPTION	ITEM #	NOTES	D	W	H	PRICE	SHIP WT.	LEAD TIME*
360 3 legged chair with back, 18"h Platinum frame. Available Glides Only 	TS0G0.18PL	glides only	23.5	26	31.25	\$372	18	S
360 3 legged chair without back, 18"h Platinum frame. Available Glides only 	TS3G0.18PL	glides only	23.5	26	18	\$294	13	S
360 chair with back without bookbag rack, 18"h. Platinum frame. 	TS1G0.18PL	glides	23.5	26	31.25	\$384	23	S
	TS1CHW0.18PL	hard wheel casters for carpeted surfaces				\$384	23	S
	TS1CSW0.18PL	soft wheel casters for hard surfaces				\$406	23	S
360 chair with back with bookbag rack, 18"h. Platinum frame. 	TS1G1.18PL	glides	23.5	26	31.25	\$424	26	S
	TS1CHW1.18PL	hard wheel casters for carpeted surfaces				\$424	26	S
	TS1CSW1.18PL	soft wheel casters for hard surfaces				\$446	26	S
360 chair without back without bookbag rack, 18"h. Platinum frame. 	TS2G0.18PL	glides	23.5	26	18	\$306	18	S
	TS2CHW0.18PL	hard wheel casters for carpeted surfaces				\$306	18	S
	TS2CSW0.18PL	soft wheel casters for hard surfaces				\$328	18	S
360 chair without back with bookbag rack, 18"h. Platinum frame. 	TS2G1.18PL	glides	23.5	26	18	\$338	20	S
	TS2CHW1.18PL	hard wheel casters for carpeted surfaces				\$338	20	S
	TS2CSW1.18PL	soft wheel casters for hard surfaces				\$360	20	S

to order

- Item Number
- Size/Frame Color
- Bookbag Rack
- Seat Finish
- Back Finish

example

TS1CHW1 - 18PL - TR - 8B - 8B
ITEM NUMBER SIZE/FRAME COLOR BOOKBAG RACK SEAT FINISH BACK FINISH
please separate each item with a dot

seat/back finish options

CODE	DESCRIPTION
8A	Black
8B	Red
8D	Sky
8E	Green Apple
8F	Orange
8I	Purple
8J	Navy
8L	Storm

bookbag rack finish options

CODE	DESCRIPTION
TS	Storm
TR	Red
TN	Navy
TG	Green Apple

frame paint finish

CODE	DESCRIPTION
8A	Platinum (only option)

360 Series

360 Series - fabric planner

For Purchase Order Number:

Project Name:

Headboard: 1 Linear Yard

Fabric Manufacturer:

Fabric Pattern:

Fabric Color:

Seat: 2 Linear Yards

Fabric Manufacturer:

Fabric Pattern:

Fabric Color:

Seat: 1 Linear Yard

Fabric Manufacturer:

Fabric Pattern:

Fabric Color:

Yardage requirements are for non-railroaded upholstery. Please contact customer service for railroading requirements or repeats over 2 inches.

This form must accompany your order. Send completed form to sales@haskelloffice.com

The lead-time of your order is directly related to when the COM fabric is received.

Please ship COM to: Haskell, 3770 Hagen Dr., Wyoming, MI 49548





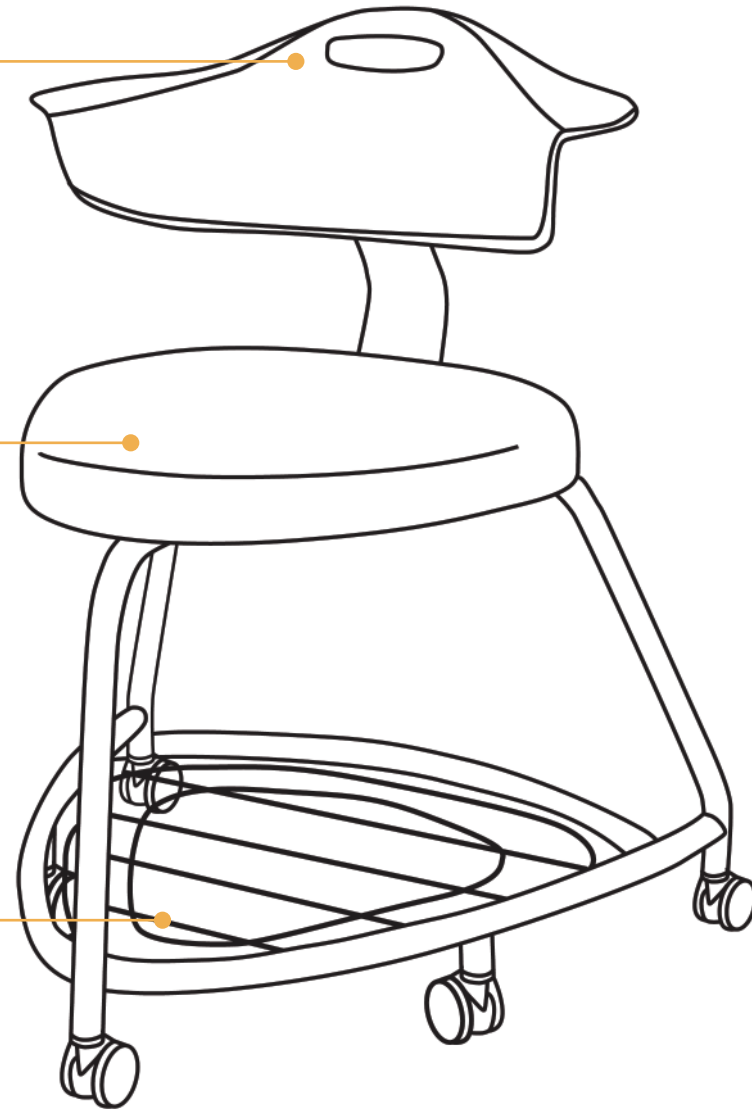

Clearly label all materials with the dealer name, project name, and purchase order number.

[Download the COM Fabric Planner for 360 Series](#)



360 Series

Upholstered Chair

DESCRIPTION	ITEM #	NOTES	D	W	H	COM PRICE	SHIP WT.	LEAD TIME*
360 3 legged chair with back, 18"h Platinum frame. Available Glides Only 	UTS0G0.18PL	glides only	23.5	26	31.25	\$472	18	S
360 3 legged chair without back, 18"h Platinum frame. Available Glides only 	UTS3G0.18PL	glides only	23.5	26	18	\$394	13	S
360 chair with back without bookbag rack, 18"h. Platinum frame. 	UTS1G0.18PL	glides	23.5	26	31.25	\$484	23	S
	UTS1CHW0.18PL	hard wheel casters for carpeted surfaces				\$484	23	S
	UTS1CSW0.18PL	soft wheel casters for hard surfaces				\$506	23	S
360 chair with back with bookbag rack, 18"h. Platinum frame. 	UTS1G1.18PL	glides	23.5	26	31.25	\$524	26	S
	UTS1CHW1.18PL	hard wheel casters for carpeted surfaces				\$524	26	S
	UTS1CSW1.18PL	soft wheel casters for hard surfaces				\$546	26	S
360 chair without back without bookbag rack, 18"h. Platinum frame. 	UTS2G0.18PL	glides	23.5	26	18	\$406	18	S
	UTS2CHW0.18PL	hard wheel casters for carpeted surfaces				\$406	18	S
	UTS2CSW0.18PL	soft wheel casters for hard surfaces				\$428	18	S
360 chair without back with bookbag rack, 18"h. Platinum frame. 	UTS2G1.18PL	glides	23.5	26	18	\$438	20	S
	UTS2CHW1.18PL	hard wheel casters for carpeted surfaces				\$438	20	S
	UTS2CSW1.18PL	soft wheel casters for hard surfaces				\$460	20	S

to order

- Item Number
- Size/Frame Color
- Bookbag Rack
- Seat Finish
- Back Finish

example

TS1CHW1 - 18PL - TR - 8B - 8B

ITEM NUMBER SIZE/FRAME COLOR BOOKBAG RACK SEAT FINISH BACK FINISH

please separate each item with a dot

back finish options

CODE	DESCRIPTION
8A	Black
8B	Red
8D	Sky
8E	Green Apple
8F	Orange
8I	Purple
8J	Navy
8L	Storm

bookbag rack finish options

CODE	DESCRIPTION
TS	Storm
TR	Red
TN	Navy
TG	Green Apple

frame paint finish

CODE	DESCRIPTION
PL	Platinum (only option)

360 Series

Stool

DESCRIPTION	ITEM #	NOTES	D	W	H	PRICE	SHIP WT.	LEAD TIME*
360 stool with back, without bookbag rack, 24"h. Platinum frame.	TS4G0.24PL	glides	23.5	26	37.25	\$448	25	S
	TS4CHW0.24PL	hard wheel casters for carpeted surfaces				\$448	25	S
	TS4CSW0.24PL	soft wheel casters for hard surfaces				\$470	25	S
360 stool with back, with bookbag rack, 24"h. Platinum frame.	TS4G1.24PL	glides	23.5	26	37.25	\$480	27	S
	TS4CHW1.24PL	hard wheel casters for carpeted surfaces				\$480	27	S
	TS4CSW1.24PL	soft wheel casters for hard surfaces				\$502	27	S
360 stool without back or bookbag rack, 24"h. Platinum frame.	TS5G0.24PL	glides	23.5	26	24	\$364	22	S
	TS5CHW0.24PL	hard wheel casters for carpeted surfaces				\$364	22	S
	TS5CSW0.24PL	soft wheel casters for hard surfaces				\$386	22	S
360 stool without back, with bookbag rack, 24"h. Platinum frame.	TS5G1.24PL	glides	23.5	26	24	\$388	22	S
	TS5CHW1.24PL	hard wheel casters for carpeted surfaces				\$388	22	S
	TS5CSW1.24PL	soft wheel casters for hard surfaces				\$410	22	S

360 Series

Stool

DESCRIPTION	ITEM #	NOTES	D	W	H	PRICE	SHIP WT.	LEAD TIME*
360 stool with back, without bookbag rac, 30"h. Platinum frame.	TS4G0.30PL	glides	23.5	26	43.25	\$464	28	S
	TS4CC0.30PL	compression casters				\$644	28	S
360 stool with back, with bookbag rack, 30"h. Platinum frame.	TS4G1.30PL	glides	23.5	26	43.25	\$494	30	S
	TS4CC1.30PL	compression casters				\$674	30	S
360 stool without back or bookbag rack, 30"h. Platinum frame.	TS5G0.30PL	glides	23.5	26	30	\$382	23	S
	TS5CC0.30PL	compression caster				\$562	23	S
360 stool without back, with bookbag rack, 30"h. Platinum frame.	TS5G1.30PL	glides	23.5	26	30	\$402	25	S
	TS5CC1.30PL	compression caster				\$582	25	S

to order

1. Item Number
2. Size/Frame Color
3. Bookbag Rack
4. Seat Finish
5. Back Finish

example

TS1CHW1 - 18PL - TR - 8B - 8B

ITEM NUMBER SIZE/FRAME COLOR BOOKBAG RACK SEAT FINISH BACK FINISH

please separate each item with a dot

seat/back finish options

CODE	DESCRIPTION
8A	Black
8B	Red
8D	Sky
8E	Green Apple
8F	Orange
8I	Purple
8J	Navy
8L	Storm

bookbag rack finish options

CODE	DESCRIPTION
TS	Storm
TR	Red
TN	Navy
TG	Green Apple

frame paint finish

CODE	DESCRIPTION
PL	Platinum (only option)

to order

1. Item Number
2. Size/Frame Color
3. Bookbag Rack
4. Seat Finish
5. Back Finish

example

TS1CHW1 - 18PL - TR - 8B - 8B

ITEM NUMBER SIZE/FRAME COLOR BOOKBAG RACK SEAT FINISH BACK FINISH

please separate each item with a dot

seat/back finish options

CODE	DESCRIPTION
8A	Black
8B	Red
8D	Sky
8E	Green Apple
8F	Orange
8I	Purple
8J	Navy
8L	Storm

bookbag rack finish options





CODE	DESCRIPTION
TS	Storm
TR	Red
TN	Navy
TG	Green Apple

frame paint finish

CODE	DESCRIPTION
PL	Platinum (only option)





360 Series

Upholstered Stool

DESCRIPTION	ITEM #	NOTES	D	W	H	COM PRICE	SHIP WT.	LEAD TIME*
360 stool with back, without bookbag rack, 24"h. Platinum frame. 	UTS4G0.24PL	glides	23.5	26	37.25	\$548	25	S
	UTS4CHW0.24PL	hard wheel casters for carpeted surfaces				\$548	25	S
	UTS4CSW0.24PL	soft wheel casters for hard surfaces				\$570	25	S
360 stool with back, with bookbag rack, 24"h. Platinum frame. 	UTS4G1.24PL	glides	23.5	26	37.25	\$580	27	S
	UTS4CHW1.24PL	hard wheel casters for carpeted surfaces				\$580	27	S
	UTS4CSW1.24PL	soft wheel casters for hard surfaces				\$602	27	S
360 stool without back or bookbag rack, 24"h. Platinum frame. 	UTS5G0.24PL	glides	23.5	26	24	\$464	22	S
	UTS5CHW0.24PL	hard wheel casters for carpeted surfaces				\$464	22	S
	UTS5CSW0.24PL	soft wheel casters for hard surfaces				\$486	22	S
360 stool without back, with bookbag rack, 24"h. Platinum frame. 	UTS5G1.24PL	glides	23.5	26	24	\$488	22	S
	UTS5CHW1.24PL	hard wheel casters for carpeted surfaces				\$488	22	S
	UTS5CSW1.24PL	soft wheel casters for hard surfaces				\$510	22	S

360 Series

Upholstered Stool

DESCRIPTION	ITEM #	NOTES	D	W	H	COM PRICE	SHIP WT.	LEAD TIME*
360 stool with back, without bookbag rac, 30"h. Platinum frame. 	UTS4G0.30PL	glides	23.5	26	43.25	\$564	28	S
	UTS4CC0.30PL	compression casters				\$744	28	S
360 stool with back, with bookbag rack, 30"h. Platinum frame. 	UTS4G1.30PL	glides	23.5	26	43.25	\$594	30	S
	UTS4CC1.30PL	compression casters				\$774	30	S
360 stool without back or bookbag rack, 30"h. Platinum frame. 	UTS5G0.30PL	glides	23.5	26	30	\$482	23	S
	UTS5CC0.30PL	compression caster				\$662	23	S
360 stool without back, with bookbag rack, 30"h. Platinum frame. 	UTS5G1.30PL	glides	23.5	26	30	\$502	25	S
	UTS5CC1.30PL	compression caster				\$682	25	S

to order

1. Item Number
2. Size/Frame Color
3. Bookbag Rack
4. Seat Finish
5. Back Finish

example

TS1CHW1 - 18PL - TR - 8B - 8B

ITEM NUMBER SIZE/FRAME COLOR BOOKBAG RACK SEAT FINISH BACK FINISH

please separate each item with a dot

back finish options

CODE	DESCRIPTION
8A	Black
8B	Red
8D	Sky
8E	Green Apple
8F	Orange
8I	Purple
8J	Navy
8L	Storm

bookbag rack finish options

CODE	DESCRIPTION
TS	Storm
TR	Red
TN	Navy
TG	Green Apple

frame paint finish

CODE	DESCRIPTION
PL	Platinum (only option)

to order

1. Item Number
2. Size/Frame Color
3. Bookbag Rack
4. Seat Finish
5. Back Finish

example

TS1CHW1 - 18PL - TR - 8B - 8B

ITEM NUMBER SIZE/FRAME COLOR BOOKBAG RACK SEAT FINISH BACK FINISH

please separate each item with a dot

back finish options

CODE	DESCRIPTION
8A	Black
8B	Red
8D	Sky
8E	Green Apple
8F	Orange
8I	Purple
8J	Navy
8L	Storm

bookbag rack finish options

CODE	DESCRIPTION
TS	Storm
TR	Red
TN	Navy
TG	Green Apple

frame paint finish

CODE	DESCRIPTION
PL	Platinum (only option)

Assemble Series

introduction



General





All Assemble Series Tables are 29" H. Worksurfaces are laminate wood core tops at 1 3/16" thick and are available with 3mm and wood edges on select models. Assemble Series Tables offers a variety of legs styles including tubular, C-tubular, arc, path and disk base. Caster, modesty panels, folding legs, and nesting options are available on select models.

Electrical Options

Assemble Series Tables offer an extensive collection of electrical options including power/data modules, grommets, and vertical/horizontal wire management. Contact customer service for a detailed quotation.

Assemble Series

conferencing & multi-purpose tables

DESCRIPTION	ITEM #	NOTES	D	W	H	(T) TUBULAR	(A) ARC	(D) DISC	(P) PATH	LEAD TIME*
						BASE	BASE	BASE	BASE	
						3MM	3MM	3MM	3MM	
 Round table w/ glides	ASH(x)-30RD	X-BASE for (T) & (A)	30"		29"	\$914	N/A	\$1198	N/A	S
	ASH(x)-36RD	X-BASE for (T) & (A)	36"		29"	\$978	\$1038	\$1258	N/A	S
	ASH(x)-42RD	X-BASE for (T) & (A)	42"		29"	\$1120	\$1160	\$1478	N/A	S
	ASH(x)-48RD	X-BASE for (T) & (A)	48"		29"	\$1314	\$1368	\$1628	N/A	S
	ASH(x)-60RD	X-BASE for (T) & (A)	60"		29"	\$1738	N/A	N/A	N/A	S
 Square table w/ glides	ASH(x)-3030SQ	X-BASE for (T) & (A)	30"	30"	29"	\$958	\$1058	\$1198	N/A	S
	ASH(x)-3636SQ	X-BASE for (T) & (A)	36"	36"	29"	\$1038	\$1120	\$1258	N/A	S
	ASH(x)-4242SQ	X-BASE for (T) & (A)	42"	42"	29"	\$1,68	\$11268	\$1478	N/A	S
	ASH(x)-4848SQ	X-BASE for (T) & (A)	48"	48"	29"	\$1658	N/A	\$1628		S
	ASH(x)-6060SQ	X-BASE for (T) & (A)	60"	60"	29"	\$1738	N/A	N/A	N/A	
 Racetrack Table w/ tubular base & glides	ASH(x)-3660RT		36"	60"	29"	\$1264	\$1264	\$2298	\$1398	S
	ASH(x)-3672RT		36"	72"	29"	\$1328	\$1324	\$2408	\$1448	S
	ASH(x)-3684RT		36"	84"	29"	\$1368	\$1398	\$2434	\$1478	S
 Bowed (boat) table w/ glides	ASH(x)-3696BT		36" Ends 42" Middle	96"	29"	\$1498	\$1428	\$2848	\$1628	S

to order	1. Item Number - replace the (?) with the base code	ASHT-30RD	MS	FF	FG	WO1G
	2. Paint Finish - (MS) metallic silver or (BK) Black	ITEM NUMBER	PAINT	LAMINATE	EDGE	OPTIONS
	3. Laminate	please separate each item with a dot				
	4. Edge Finish					
	5. Options					

wire management options			power & data options		
MODEL	DESCRIPTION	PRICE	MODEL	DESCRIPTION	PRICE
WO1G	(1) Grommet, centered on table worksurface	\$58	POPM	Plastic power module (2) power (2) data jacks, centered on worksurface	\$390
WO36	36" Wire Manager, Field Trimtable	\$132	POAM	Aluminum power module (2) power (2) data jacks, centered on worksurface	\$625
WO48	48" Wire Manager, Field Trimtable	\$144			
WO60	60" Wire Manager, Field Trimtable	\$162			
WO72	72" Wire Manager, Field Trimtable	\$172			
WOCS	Cable Spine	\$430			

Captiva™ Series

introduction - pedestals



Pedestals shown with full, recessed and loop pulls. Full pulls only are available.

General

All Captiva™ Pedestals are 14 7/8" in width. All file drawers are designed to accommodate hanging folders. Mobile units are standard with counterweights to reduce the likelihood of tipping. However, it is recommended that not more than one heavily loaded drawer be opened at one time. Caution should be exercised when pedestals are used as freestanding units.

Assembly

All units ship fully assembled.

Locks

Captiva™ Pedestals come standard with a removable core lock for easy reconfiguration on site. Units can be keyed alike to other Haskell Products upon request.

Unit Construction

The Captiva™ Series Pedestal drawer fronts are external to the case and are referred to as Proud.

Wood Core Tops

Laminate tops are available as a separate component. Tops are available with a 3mm edge. All wood core tops are 1 1/8" thick.

Casters/Glides

Captiva™ Pedestals are available with either adjustable glides or casters. Casters and glides are easily interchangeable in the field.

COM

All COM yardage is based on a 54" wide fabric.

Keying Information and Locking Options

All locks feature a removable core which is easily removed on site. All lock cores are interchangeable through all products as cores are universal.

Locks throughout an order or locks within a particular workstation can be keyed alike at no additional charge if specified when ordering. Keyed Alike means that all locks are identical. To order, specify which products are to be keyed alike and order a "Removable Core Lock Kit" for each group of products to be keyed alike. The specified products will be shipped without lock cores. The cores for each workstation will be packaged separately. All Removable Core Lock Kits are shipped with a control key for removing or inserting lock cores. Note that a control key works only when a lock is in the unlocked position.

Master keys, which operate any removable core lock, are available for \$35 net each.

One control key is provided for each "key alike" order. If additional keys are needed, cost is \$35 net each.

Additional keys can be purchased for \$15 net per key.

Captiva™ Series

worksurface supporting and fixed pedestals w/ proud drawers

DESCRIPTION	ITEM #	D	W	H	PRICE	SHIP WT.	LEAD TIME*
Worksurface Supporting Pedestals file/file, open top	WP18FF	17 1/4"	14 7/8"	27 5/8"	\$734	85	E
	WP24FF	22 7/8"	14 7/8"	27 5/8"	\$744	85	E
	WP28FF	28 7/8"	14 7/8"	27 5/8"	\$830	85	E
Worksurface Supporting Pedestals box/box/file, open top	WP18BBF	17 1/4"	14 7/8"	27 5/8"	\$754	88	E
	WP24BBF	22 7/8"	14 7/8"	27 5/8"	\$764	88	E
	WP28BBF	28 7/8"	14 7/8"	27 5/8"	\$850	88	E
Fixed Pedestal file/file	FP18FF	17 1/4"	14 7/8"	27 5/8"	\$760	87	E
	FP24FF	22 7/8"	14 7/8"	27 5/8"	\$770	87	E
	FP28FF	28 7/8"	14 7/8"	27 5/8"	\$856	87	E
Fixed Pedestal box/box/file	FP18BBF	17 1/4"	14 7/8"	27 5/8"	\$780	83	E
	FP24BBF	22 7/8"	14 7/8"	27 5/8"	\$790	83	E
	FP28BBF	28 7/8"	14 7/8"	27 5/8"	\$876	83	E

to order

1. Item Number
2. Pull Style
3. Paint Finish

example

WP18FF - FL - 5503
ITEM NUMBER PULL STYLE PAINT FINISH
please separate each item with a dash

drawer pull options



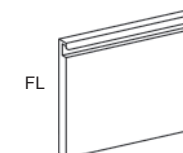

MODEL DESCRIPTION

FL Full

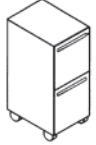

Captiva™ Series

mobile pedestals w/ proud drawers

DESCRIPTION	ITEM #	COM	D	W	H	PRICE	SHIP WT.	LEAD TIME*
Mobile Pedestal w/ casters file/file 	MP18FF		17 1/4"	14 7/8"	27 1/2"	\$868	83	E
	MP24FF		22 7/8"	14 7/8"	27 1/2"	\$928	83	E
	MP28FF		28 7/8"	14 7/8"	27 1/2"	\$988	83	E
Mobile Pedestal w/ casters box/box/file 	MP18BBF		17 1/4"	14 7/8"	27 1/2"	\$878	87	E
	MP24BBF		22 7/8"	14 7/8"	27 1/2"	\$938	87	E
	MP28BBF		28 7/8"	14 7/8"	27 1/2"	\$1004	87	E
Mobile Pedestal cushion top & zeal casters box/file 	ZMPF24BF	1 YD	22 7/8"	14 7/8"	24 1/8"	\$1168	80	E
Mobile Pedestal metal top & zeal casters box/file 	ZMP24BF	1 YD	22 7/8"	14 7/8"	23 7/8"	\$868	80	E

- to order
1. Item Number
 2. Pull Style
 3. Paint Finish
 4. Fabric (for cushion top pedestal only)

example **MP18FF - FL - 5503 -**
ITEM NUMBER PULL STYLE PAINT FINISH FABRIC
please separate each item with a dash

drawer pull options

MODEL DESCRIPTION

FL Full

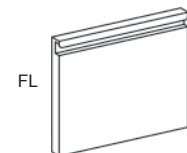

notes

Pedestals come with the following:
 - 2 keys
 - Pencil Tray
 - Side-Side / Front-Back Filing

Captiva™ Series

pedestals accessories

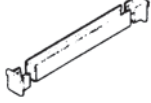
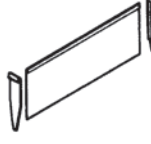
DESCRIPTION	ITEM #	SIZE/DESCRIPTION	PRICE	SHIP WT.	LEAD TIME*
Pedestal Side to Side Bar 	OHASFB	Allows users to file letter or legal width files side to side	\$40		
Pedestal Drawer Divider 	OHABDD	For box drawers	\$78		
File Compressor	OHCOMP	File drawer compressor	\$58		

- to order
1. Item Number

example **OHASFB**
ITEM NUMBER

Captiva™ Series

introduction - lateral files & storage cabinets



General

All Captiva™ Lateral Files are constructed using Haskell's unique "Double O" frame construction for outstanding strength and durability. Captiva™ Lateral Files and Overfile units are 18" deep. Adjustable glides are standard at the front and rear of all cases. Files are designed with dual lock bars and safety interlock mechanisms integrated into the suspensions. All standard lateral files with fixed front drawers come with a set of hanging folder frames for side-to-side filing. Two dividers can be substituted for side-to-side rails at no charge if specified when ordering. Front-to-back filing bars may be ordered separately for field installation. All drawer fronts are field replaceable.

Suspensions

All Captiva™ Lateral Files have heavy duty, fully progressive steel ball bearing suspensions with integrated slide lock system. The integrated slide lock system has the interlock built into the drawer slide to enable a more positive interlock system.

Assembly

All units ship fully assembled. Interior drawer accessories are field-installed only.

Locks

Captiva™ Laterals come standard with a removable core lock for easy reconfiguration on site. Units can be keyed alike to other Haskell Products upon request.

Wood Core Tops

Laminate tops are available as a separate component to span multiple files. Tops are available with a 3mm edge. All wood core tops are 1 1/8" thick.

Unit Construction

The Captiva™ Series Laterals are offered with flush style drawer fronts.

Keying Information and Locking Options

All locks feature a removable core which is easily removed on site. All lock cores are interchangeable through all products as cores are universal.

Locks throughout an order or locks within a particular workstation can be keyed alike at no additional charge if specified when ordering. "Keyed Alike" means that all locks are identical. To order, specify which products are to be keyed alike and order a "Removable Core Lock Kit" for each group of products to be keyed alike. The specified products will be shipped without lock cores. The cores for each workstation will be packaged separately. All Removable Core Lock Kits are shipped with a control key for removing or inserting lock cores. Note that a control key works only when a lock is in the unlocked position.

Master keys, which operate any removable core lock, are available for \$35 net each.

One control key is provided for each "key alike" order. If additional keys are needed, cost is \$35 net each.

Additional keys can be purchased for \$15 net per key.

Captiva™ Series

lateral files w/ 12" flush drawers

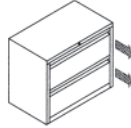
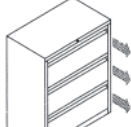
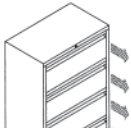
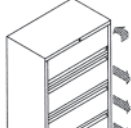
DESCRIPTION	ITEM #	D	W	H	PRICE	SHIP WT.	LEAD TIME*
Two High (2) 12" flush drawers 	LA12F-3024-2D	18"	30"	28"	\$1408	103	E
	LA12F-3624-2D	18"	36"	28"	\$1570	119	E
	LA12F-4224-2D	18"	42"	28"	\$1774	134	E
Three High (3) 12" flush drawers 	LA12F-3036-3D	18"	30"	40"	\$1880	143	E
	LA12F-3636-3D	18"	36"	40"	\$2020	162	E
	LA12F-4236-3D	18"	42"	40"	\$2134	181	E
Four High (4) 12" flush drawers 	LA12F-3048-4D	18"	30"	52"	\$2494	182	E
	LA12F-3648-4D	18"	36"	52"	\$2978	205	E
	LA12F-4248-4D	18"	42"	52"	\$2964	227	E
Five High (4) 12" flush drawers & (1) 12" receding door w/ roll out shelf 	LA12F-3060-4D1R	18"	30"	64"	\$2764	221	E
	LA12F-3660-4D1R	18"	36"	64"	\$3194	248	E
	LA12F-4260-4D1R	18"	42"	64"	\$3294	274	E

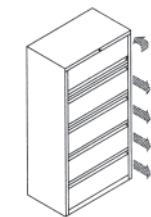

to order

1. Item Number
2. Pull Style
3. Paint Finish

example

LA12F-3024-2D - FL - 5503
ITEM NUMBER PULL STYLE PAINT FINISH
please separate each item with a dash

drawer pull options

MODEL DESCRIPTION



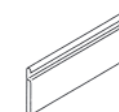

FL Full

FL



Captiva™ Series

storage lockers

DESCRIPTION	ITEM #	D	W	H	PRICE	SHIP WT.	LEAD TIME*
2 Tier Locker with Legs (INDV DIM: 12W x 18D x 30H)	LK2121866L	18"	12"	66"	\$3240	180	E
							
2 Tier Locker with Legs (INDV DIM: 12W x 18D x 36H)	LK2121878L	18"	12"	78"	\$3348	182	E
							
4 Tier Locker with Legs (INDV DIM: 15W x 18D x 18H)	LK415181878	18"	15"	78"	\$2302	190	E
							
2 Tier 3 Lockers Per Horizontal Row (Total 6 Indv Lockers) with Legs (INDV DIM: 15W x 18D x 36H)	LK615183678	18"	45"	78"	\$2302	385	E
							

to order

1. Item Number
2. Paint Finish

example LK2121866L - 5503

ITEM NUMBER PAINT FINISH

please separate each item with a dash



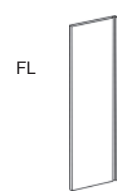

drawer pull

MODEL	DESCRIPTION
FL	Full

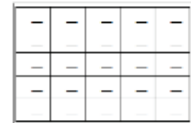

Captiva™ Series

storage lockers

DESCRIPTION	ITEM #	D	W	H	PRICE	SHIP WT.	LEAD TIME*
Individual Locker with Legs, 4 Coat Hooks, Coat Rod and Shelf	LK4121266L	12"	12"	66"	\$3020	177	E
	LK4121278L	12"	12"	78"	\$3104	191	E
	LK4121866L	18"	12"	66"	\$3430	188	E
	LK4121566L	15"	12"	66"	\$2896	182	E
	LK4121578L	15"	12"	78"	\$3430	196	E
LK4182178P	18"	12"	78"	\$2368	202	E	
							
15-Door Cell Phone Locker with Individual Label Holder and Lock	CPL243115	9"	24"	31"	\$2808	85	E
							
25-Door Cell Phone Locker with Individual Label Holder and Lock	CPL243125	9"	36"	31"	\$3078	121	E
							
36-Door Cell Phone Locker with Individual Label Holder and Lock	CPL243136	9"	28"	78"	\$3298	304	E
							

to order

1. Item Number
2. Paint Finish

example LK4121266L - 5503

ITEM NUMBER PAINT FINISH

please separate each item with a dash

drawer pull

MODEL	DESCRIPTION
FL	Full

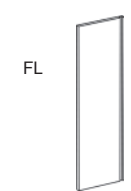

Captiva™ Series

heavy duty storage

DESCRIPTION	ITEM #	D	W	H	PRICE	SHIP WT.	LEAD TIME*
Industrial Shelving w/ adjustable Shelves	SU362475-6 (6) Adjustable Shelves	24"	48"	75"	\$2646	121	E
	SU361887-8 (8) Adjustable Shelves	18"	36"	87"	\$2742	133	E



Industrial Cabinet w/ adjustable Shelves	SU362487-8 Closed Storage No Doors (8) Adjustable Shelves	24"	36"	87"	\$2940	243	E
	SU361878-6 (6) Adjustable Shelves	18"	36"	78"	\$3062	261	E

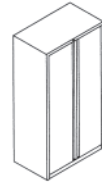

to order

- Item Number
- Paint Finish

See paint finish options below

example SU362475-6 - 26

ITEM NUMBER PAINT FINISH

please separate each item with a dash

drawer pull

MODEL	DESCRIPTION
FL	Full

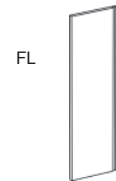

paint finish options

MODEL	DESCRIPTION
26	Soft Gray

Captiva™ Series

lateral files laminate tops

DESCRIPTION	ITEM NUMBER	NOTE	D	W	3MM EDGE	SHIP WT.	LEAD TIME*
Laminate Tops	HKLFT1830	For (1) 30" W lateral file	18"	30"	\$312	18	E
	HKLFT1836	For (1) 36" W lateral file	18"	36"	\$348	20	E
	HKLFT1842	For (1) 42" W lateral file	18"	42"	\$358	25	E
	HKLFT1860	For (2) 30" W lateral files	18"	60"	\$414	35	E
	HKLFT1872	For (2) 36" W lateral files	18"	72"	\$498	42	E
	HKLFT1884	For (2) 42" W lateral files	18"	84"	\$568	49	E

to order

- Item Number
- Laminate
- Edge Finish

example HKLFT1830 - HS - 4072

ITEM NUMBER LAMINATE EDGE FINISH

please separate each item with a dash

Captiva™ Series

lateral files accessories

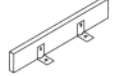
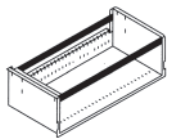
DESCRIPTION	ITEM #	NOTE	PRICE	SHIP WT.	LEAD TIME*
Metal Counter Weight	CWF	For use with any size lateral or vertical file	\$248	20	E
					
Flush Hanging Bars front-to-back	FBS/18-2-F	Sold as set, one set required per drawer. For use in any size lateral file	\$88	1	E
Flush Hanging Bars side-to-side	SSS-30-F	For 30" W drawers	\$88	1	E
	SSS-36-F	For 36" W drawers	\$88	1	E
	SSS-42-F	For 42" W drawers	\$88	1	E
					
Proud Hanging Bars front-to-back	FBS/18-2-P	Sold as set, one set required per drawer. For use in any size lateral file	\$88	1	E
Proud Hanging Bars side-to-side	SSS-30-P	For 30" W drawers	\$88	1	E
	SSS-36-P	For 36" W drawers	\$88	1	E
	SSS-42-P	For 42" W drawers	\$88	1	E

to order

1. Item Number

example

CWF
ITEM NUMBER

Captiva™ Series

introduction - vertical files



General

All Captiva™ Vertical Files are constructed using Haskell's unique "Double O" frame construction for outstanding strength and durability. Captiva™ Vertical Files are 28" in exterior depth with an interior filing capacity of 25 ½" and each unit ships with a spring loaded mechanical compressor in each drawer. Captiva™ Vertical Files come standard with the Haskell S.I.S.™ safety interlock system integrated within each slide, allowing only one drawer to open at a time. All vertical files are available in 14 ¾" (letter) or 17 ¾" (legal) widths. Adjustable glides are standard at the front and rear of all cases and all files drawers have been designed to accommodate hanging folders.

Suspensions:

All Captiva™ Vertical Files have heavy duty, fully progressive steel ball bearing suspensions with integrated slide lock system.

Assembly

All units ship fully assembled. Interior drawer accessories are field-installed only.

Locks

Captiva™ Vertical Files come standard with a removable core lock for easy reconfiguration on site. Units can be keyed alike to other Haskell Products upon request.

Unit Construction

The Captiva™ Series Vertical drawer fronts are external to the case and are referred to as Proud.

Wood Core Tops

Laminate tops are available as a separate component to span one to four files. Tops are available with a 3mm edge. All wood core tops are 1 ½" thick.

Keying Information and Locking Options

All locks feature a removable core which is easily removed on site. All lock cores are interchangeable through all products as cores are universal.

Locks throughout an order or locks within a particular workstation can be keyed alike at no additional charge if specified when ordering. Keyed Alike means that all locks are identical. To order, specify which products are to be keyed alike and order a "Removable Core Lock Kit" for each group of products to be keyed alike. The specified products will be shipped without lock cores. The cores for each workstation will be packaged separately. All Removable Core Lock Kits are shipped with a control key for removing or inserting lock cores. Note that a control key works only when a lock is in the unlocked position.

Master keys, which operate any removable core lock, are available for \$35 net each.

One control key is provided for each "key alike" order. If additional keys are needed, cost is \$35 net each.

Additional keys can be purchased for \$15 net per key.

Captiva™ Series

letter width vertical file w/ proud drawers

DESCRIPTION	ITEM #	D	W	H	PRICE	SHIP WT.	LEAD TIME*
Letter Two High	HVFR2	28"	14 ¾"	28"	\$998	72	E



Letter Three High	HVFR3	28"	14 ¾"	40"	\$1468	98	E
-------------------	-------	-----	-------	-----	--------	----	---

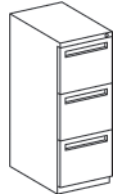

Letter Four High	HVFR4	28"	14 ¾"	52"	\$1828	125	E
------------------	-------	-----	-------	-----	--------	-----	---



Letter Five High	HVFR5	28"	14 ¾"	64"	\$2048	148	E
------------------	-------	-----	-------	-----	--------	-----	---



to order

1. Item Number
2. Pull Style
3. Paint Finish

example HVFR2 - FL - 5503

ITEM NUMBER	PULL STYLE	PAINT FINISH
HVFR2	FL	5503

please separate each item with a dash

drawer pull options

MODEL DESCRIPTION

FL Full

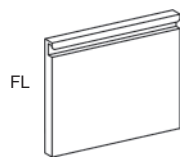

Captiva™ Series

vertical files laminate tops

DESCRIPTION	ITEM NUMBER	NOTE	D	W	3MM EDGE	SHIP WT.	LEAD TIME*
Laminate Tops for letter width files	HKVF1428	For (1) letter width file	28 ¾"	14 ⅝"	\$218	12	E
	HKVF2928	For (2) letter width files	28 ¾"	30"	\$304	22	E
	HKVF4328	For (3) letter width files	28 ¾"	45 ⅞"	\$378	32	E
	HKVF5828	For (4) letter width files	28 ¾"	60"	\$448	42	E

to order

1. Item Number
2. Laminate
3. Edge Finish

example HKVF1428 - HS - 4072

ITEM NUMBER	LAMINATE	EDGE FINISH
HKVF1428	HS	4072

please separate each item with a dash

Captiva™ Series

introduction - bookcases



General

All Captiva™ Bookcases are 14" in exterior depth and are available in three standard widths 30", 36" and 42". Captiva™ Bookcases have 2 height options 27 1/2", 42". Adjustable glides are standard at the front and rear of all cases.

Shelf Configuration

All Captiva™ Bookcases have (1) fixed bottom shelf.

- 27 1/2" high bookcases have (1) adjustable shelf.
- 42" high bookcases have (2) adjustable shelves.

Each Adjustable shelf includes 4 clips to position the shelf at customer's preference. Additional shelves are available.

Assembly

All units ship fully assembled.

Installation



Correct installation should include proper leveling and ganging of multiple units.

Wood Core Tops

Laminate tops are available as a separate component. Tops are available with a 3mm edge. All wood core tops are 1 1/8" thick.

Captiva™ Series

bookcases

DESCRIPTION	ITEM #	NOTE	D	W	H	PRICE	SHIP WT.	LEAD TIME*
Bookcase, 27 1/2"H (1) adjustable shelf 	BC215-30		14"	30"	27 1/2"	\$798	40	E
	BC215-36		14"	36"	27 1/2"	\$878	46	E
	BC215-42		14"	42"	27 1/2"	\$928	52	E
Bookcase, 42"H (2) adjustable shelves 	BC315T-36		14"	36"	42"	\$1038	68	E
Adjustable Shelves (4) clips	HFBC3015SH	For 30" W bookcase	14"	30"		\$162	5	E
	HFBC3615SH	For 36" W bookcase	14"	36"		\$168	5	E
	HFBC4215SH	For 42" W bookcase	14"	42"		\$182	5	E
Shelf Divider	SD9-2PACK			8"	7 1/2"	\$148	12	E

to order

1. Item Number
2. Paint Finish

example

BC215-30 - 5503

ITEM NUMBER PAINT FINISH

please separate each item with a dash

Captiva™ Series

bookcases laminate tops

DESCRIPTION	ITEM NUMBER	NOTE	D	W	3MM EDGE	SHIP WT.	LEAD TIME*
Laminate Tops for bookcases	HKBCT1430	For 30" W bookcase	14"	30"	\$276	20	E
	HKBCT1436	For 36" W bookcase	14"	36"	\$304	24	E
	HKBCT1442	For 42" W bookcase	14"	42"	\$338	28	E

Disco series

introduction

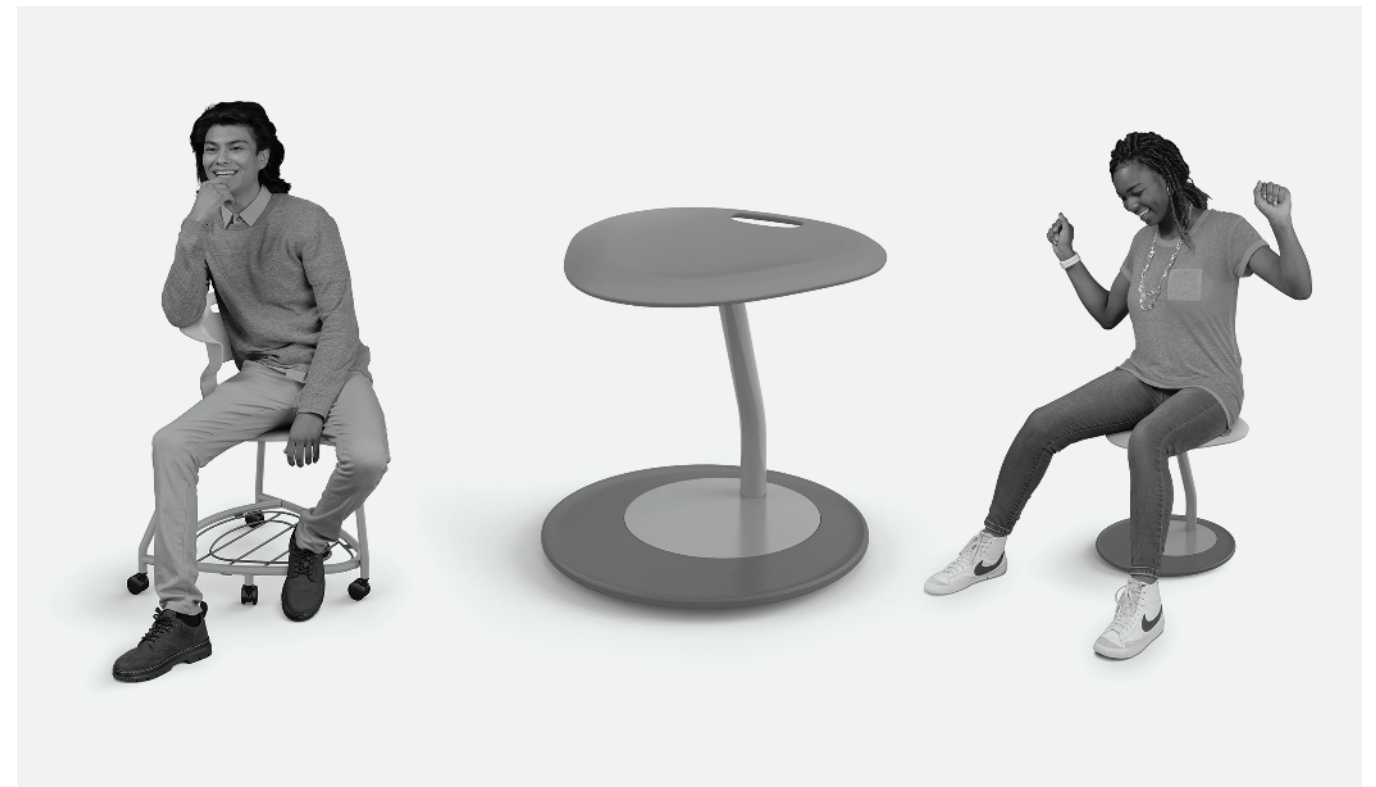

General

A sophisticated active learning stool that supports multiple body types and sizes allowing students to pivot, spin and rock in a 360-degree motion. When you hear the word disco, it conjures thoughts of movement, energy and having fun. At the same time, the Latin meaning for the word disco is "I Learn." It's the perfect pairing of meanings. Learning at its core should be energized and fun. And we know that simply being able to move during class time is a big part of that equation.

to order

1. Item Number
2. Laminate
3. Edge Finish

example **HKBCT1430 - HS - 4072**

ITEM NUMBER	LAMINATE	EDGE FINISH
HKBCT1430	HS	4072

please separate each item with a dash

Disco Series

Stool

DESCRIPTION	ITEM #	NOTES	D	W	H	PRICE	SHIP WT.	LEAD TIME*
Disco active learning stool. Platinum frame, Storm base	DS1.18		18	18	18	\$334	19	S

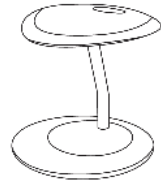

Disco Series

Stool - fabric planner

For Purchase Order Number:

Project Name:

Seat: 2 Linear Yards

Fabric Manufacturer:

Fabric Pattern:

Fabric Color:

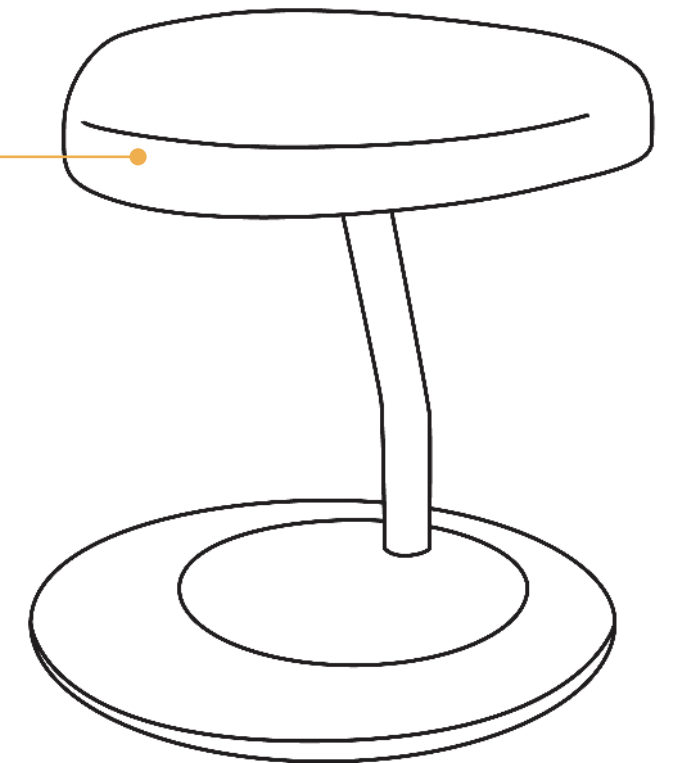

to order

example

1. Item Number (replace xx with caster option where applicable)
 2. Size (18" only)
 3. Paint (Platinum only)
 4. Seat Finish

DS1 - 18 - PL - 8B

ITEM NUMBER Size Paint Seat Finish

please separate each item with a dash

shell finish options

CODE	DESCRIPTION
8A	Black
8B	Red
8D	Sky
8E	Green Apple
8F	Orange
8I	Purple
8J	Navy
8L	Storm

Frame Finish Option

CODE	DESCRIPTION
P2	Platinum

to order

example

Yardage requirements are for non-railroaded upholstery. Please contact customer service for railroading requirements or repeats over 2 inches.

This form must accompany your order. Send completed form to sales@haskelloffice.com

The lead-time of your order is directly related to when the COM fabric is received.

Please ship COM to: Haskell, 3770 Hagen Dr., Wyoming, MI 49548

Clearly label all materials with the dealer name, project name, and purchase order number.

[Download the COM Fabric Planner for Disco Stool](#)

Disco Series

Upholstered Stool

DESCRIPTION	ITEM #	NOTES	D	W	H	PRICE	SHIP WT.	LEAD TIME*
Disco active learning stool. Platinum frame, Storm base	UDS1.18		18	18	18	\$434	19	S

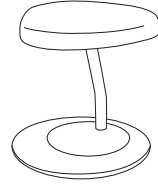

Echo™ Series

introduction



General

The Echo™ Series educator desks are 29" H, worksurfaces are laminate wood core tops at 1 3/16" thick and are available with a 3mm edge. Echo™ Series legs are offered in a standard Platinum paint finish.

to order

1. Item Number (replace xx with caster option where applicable)
2. Size (18" only)
3. Paint (Platinum only)
4. Seat Finish

example

DS1 - 18 - PL - COM

ITEM NUMBER Size Paint Seat Finish

please separate each item with a dash

Seat option



CODE	DESCRIPTION
COM	Upholstered

Frame Finish Option

CODE	DESCRIPTION
P2	Platinum

Echo™ Series

individual student desk

DESCRIPTION	ITEM #	D	W	H	Standard Laminate	F9 (WRITEABLE)	SHIP WT.	LEAD TIME*
					3MM EDGE	3MM EDGE		
Echo™ 22" Deep Rectangular Individual Student Desk w/ Echo™ base & caster 	3ECH01.2226.PL	22"	26"	29"	\$684	\$754	60	S
Echo™ 24" Deep Rectangular Individual Student Desk w/ Echo™ base & casters 	3ECH01.2434.PL	24"	34"	29"	\$730	\$838	60	S
Echo™ 24" Deep Keystone Individual Student Desk w/ Echo™ base & casters 	3ECH09.2434.PL	22"	34"	29"	\$730	\$838	60	S

to order

- Item Number
- Laminate
- Edge Finish

example 3ECH01.2226.PL - GL - FG
ITEM NUMBER LAMINATE EDGE FINISH
please separate each item with a dot

top options (list as separate lines on your order)

MODEL	DESCRIPTION	PRICE
3BOMC	Magnetic Clips (not to be used with side hooks)	\$82
3BOTDH2	Side Hooks (2) and Side Docks (2) (Offered in (PL) Platinum)	\$104
BTMP22	22" Modesty panel (to be used on a 34"w or 39"w table)	\$104
BOF1	(1) Grommet with device and cupholder **Not available on 3ECH01.2226 PL	\$58

paint finish options



MODEL	DESCRIPTION	LEAD TIME
PL	Platinum	Standard 4-6 weeks

pin height adjustable leg options

MODEL	DESCRIPTION	PRICE
ADA Compliant 24" to 35" (Add A in front of item #)		\$230
Standing Height 28" to 41" (Add SH in front of item #)		\$230

Echo™ Series

individual student desk

DESCRIPTION	ITEM #	D	W	H	Standard Laminate	F9 (WRITEABLE)	SHIP WT.	LEAD TIME*
					3MM EDGE	3MM EDGE		
Echo 22" Deep Rectangular Individual Student Desk w/ Echo base, glides (1 side) & locking casters (1 side) 	3ECH02.2226.PL	22"	26"	29"	\$670	\$772	60	S
Echo 24" Deep Rectangular Individual Student Desk w/ Echo base, glides (1 side) & locking casters (1 side) 	3ECH02.2434.PL	24"	34"	29"	\$716	\$838	60	S
Echo 24" Deep Keystone Individual Student Desk w/ Echo base, glides (1 side) & locking casters (1 side) 	3ECH09W.2434.	24"	34"	29"	\$716	\$838	60	S

to order

- Item Number
- Laminate
- Edge Finish

example 3ECH01.2226.PL - GL - FG
ITEM NUMBER LAMINATE EDGE FINISH
please separate each item with a dot

top options (list as separate lines on your order)

MODEL	DESCRIPTION	PRICE
3BOMC	Magnetic Clips (not to be used with side hooks)	\$82
3BOTDH2	Side Hooks (2) and Side Docks (2) (Offered in (PL) Platinum)	\$104
BTMP22	22" Modesty panel (to be used on a 34"w or 39"w table)	\$104
BOF1	(1) Grommet with device and cupholder **Not available on 3ECH01.2226 PL	\$58

paint finish options

MODEL	DESCRIPTION	LEAD TIME
PL	Platinum	Standard 4-6 weeks

pin height adjustable leg options

MODEL	DESCRIPTION	PRICE
ADA Compliant 24" to 35" (Add A in front of item #)		\$230
Standing Height 28" to 41" (Add SH in front of item #)		\$230

Echo™ Series

individual student desk

DESCRIPTION	ITEM #	D	W	H	Standard Laminate	F9 (WRITEABLE)	SHIP WT.	LEAD TIME*
-------------	--------	---	---	---	-------------------	----------------	----------	------------

					3MM EDGE	3MM EDGE		
Echo 22" Deep Rectangular Individual Student Desk w/ Echo base & glides	3ECH03.2226.PL	22"	26"	29"	\$664	\$766	60	S



Echo 24" Deep Rectangular Individual Student Desk w/ Echo base & glides	3ECH03.2434.PL	24"	34"	29"	\$710	\$832	60	S
---	----------------	-----	-----	-----	-------	-------	----	---



Echo 24" Deep Keystone Individual Student Desk w/ Echo base & glides	3ECH09G.2434.	24"	34"	29"	\$710	\$832	60	S
--	---------------	-----	-----	-----	-------	-------	----	---



DESCRIPTION	ITEM #	D	W	H	PRICE	SHIP WT.	LEAD TIME*
-------------	--------	---	---	---	-------	----------	------------

Personal Marker Board (item sold separately)	MB2318H	1"	23"	18"	\$224	6	S
--	---------	----	-----	-----	-------	---	---



to order

- Item Number
- Laminate
- Edge Finish

example **3ECH01.2226.PL - GL - FG**

ITEM NUMBER LAMINATE EDGE FINISH

please separate each item with a dot

top options (list as separate lines on your order)

MODEL	DESCRIPTION	PRICE
3BOMC	Magnetic Clips (not to be used with side hooks)	\$82
3BOTDH2	Side Hooks (2) and Side Docks (2) (Offered in (PL) Platinum)	\$104
BTMP22	22" Modesty panel (to be used on a 34"w or 39"w table)	\$104
BOF1	(1) Grommet with device and cupholder **Not available on 3ECH01.2226 PL	\$58

paint finish options

MODEL	DESCRIPTION	LEAD TIME
PL	Platinum	Standard 4-6 weeks

pin height adjustable leg options

MODEL	DESCRIPTION	PRICE
ADA Compliant 24" to 35" (Add A in front of item #)		\$230
Standing Height 28" to 41" (Add SH in front of item #)		\$230

Echo™ Series

19" deep rectangular training and teaming tables

DESCRIPTION	ITEM #	NOTES	D	W	H	Standard Laminate	F9 (WRITEABLE)	SHIP WT.	LEAD TIME*
-------------	--------	-------	---	---	---	-------------------	----------------	----------	------------

						3MM EDGE	3MM EDGE		
Echo™ 19" Deep Rectangular Training Table w/ Echo™ base & locking casters	3ECH01.1939.PL		19"	39"	29"	\$698	\$768	56	S
	3ECH01.1948.PL		19"	48"	29"	\$728	\$802	63	S
	3ECH01.1960.PL		19"	60"	29"	\$820	\$912	75	S
	3ECH01.1966.PL		19"	66"	29"	\$940	\$1036	78	S
	3ECH01.1972.PL		19"	72"	29"	\$984	\$1094	82	S
3ECH01.1984.PL		19"	84"	29"	\$1064	\$1194	94	S	



Echo™ 19" Deep Rectangular Training Table w/ Echo™ base, glides (1 side) and locking casters (1 side)	3ECH02.1939.PL		19"	39"	29"	\$686	\$756	56	S
	3ECH02.1948.PL		19"	48"	29"	\$716	\$790	63	S
	3ECH02.1960.PL		19"	60"	29"	\$808	\$900	75	S
	3ECH02.1966.PL		19"	66"	29"	\$928	\$1024	78	S
	3ECH02.1972.PL		19"	72"	29"	\$972	\$1082	82	S
3ECH02.1984.PL		19"	84"	29"	\$1052	\$1182	94	S	



Echo™ 19" Deep Rectangular Training Table w/ Echo™ base & glides	3ECH03.1939.PL		19"	39"	29"	\$674	\$744	56	S
	3ECH03.1948.PL		19"	48"	29"	\$704	\$778	63	S
	3ECH03.1960.PL		19"	60"	29"	\$896	\$988	75	S
	3ECH03.1966.PL		19"	66"	29"	\$916	\$1012	78	S
	3ECH03.1972.PL		19"	72"	29"	\$960	\$1070	82	S
3ECH03.1984.PL		19"	84"	29"	\$1040	\$1170	94	S	



DESCRIPTION	ITEM #	NOTES	D	W	H	PRICE	SHIP WT.	LEAD TIME*
-------------	--------	-------	---	---	---	-------	----------	------------

Personal Marker Board (item sold separately)	MB2318H	Marker board trim offered in Gray (8M) Magnets can be used with marker boards	1"	23"	18"	\$224	6	S
--	---------	--	----	-----	-----	-------	---	---

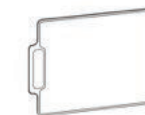

to order

- Item Number
- Laminate
- Edge Finish

example **3ECH01.1939.PL - GL - FG**

ITEM NUMBER LAMINATE EDGE FINISH

please separate each item with a dot

top options (list as separate lines on your order)

MODEL	DESCRIPTION	PRICE
3BOMC	Magnetic Clips (not to be used with side hooks)	\$82
3BOTDH2	Side Hooks (2) and Side Docks (2) (Offered in (PL) Platinum)	\$104
3BOTDH	Side Hooks (2), Center Dock (1) and Side Docks(2) (Offered in (PL) Platinum * for use on 60"w and up	\$104
3BODH	Back pack hooks (2)	\$82
BTMP22	22" Modesty panel (to be used on a 34"w or 39"w table)	\$104
BTMP32	32" Modesty Panel (to be used on a 48"w table)	\$122
BTMP43	43" Modesty Panel (to be used on a 60"w or 66"w table)	\$140
BTMP55	55" Modesty Panel (to be used on a 72"w or 84"w table)	\$164

paint finish options



MODEL	DESCRIPTION	LEAD TIME
PL	Platinum	Standard 4-6 weeks

pin height adjustable leg options

DESCRIPTION	PRICE
ADA Compliant 24" to 35" (Add A in front of item #)	\$230
Standing Height 28" to 41" (Add SH in front of item #)	\$230

Echo™ Series

24” deep rectangular training and teaming tables

DESCRIPTION	ITEM #	NOTES	D	W	H	Standard Laminate		SHIP WT.	LEAD TIME*
						F9 (WRITEABLE)			
						3MM EDGE	3MM EDGE		
 Echo™ 24” Deep Rectangular Training Table w/ Echo™ base & locking casters	3ECH01.2439.PL		24"	39"	29"	\$768	\$848	68	S
	3ECH01.2448.PL		24"	48"	29"	\$844	\$930	70	S
	3ECH01.2460.PL		24"	60"	29"	\$920	\$1024	84	S
	3ECH01.2466.PL		24"	66"	29"	\$960	\$1068	90	S
	3ECH01.2472.PL		24"	72"	29"	\$980	\$1102	94	S
3ECH01.2484.PL		24"	84"	29"	\$1108	\$1268	108	S	
 Echo™ 24” Deep Rectangular Training Table w/ Echo™ base, glides (1 side) & locking casters (1 side)	3ECH02.2439.PL		24"	39"	29"	\$754	\$834	68	S
	3ECH02.2448.PL		24"	48"	29"	\$830	\$916	70	S
	3ECH02.2460.PL		24"	60"	29"	\$906	\$1010	84	S
	3ECH02.2466.PL		24"	66"	29"	\$946	\$1054	90	S
	3ECH02.2472.PL		24"	72"	29"	\$966	\$1088	94	S
3ECH02.2484.PL		24"	84"	29"	\$1094	\$1254	108	S	
 Echo™ 24” Deep Rectangular Training Table w/ Echo™ base & glides	3ECH03.2439.PL		24"	39"	29"	\$748	\$828	68	S
	3ECH03.2448.PL		24"	48"	29"	\$824	\$910	70	S
	3ECH03.2460.PL		24"	60"	29"	\$898	\$1002	84	S
	3ECH03.2466.PL		24"	66"	29"	\$940	\$1048	90	S
	3ECH03.2472.PL		24"	72"	29"	\$960	\$1082	94	S
3ECH03.2484.PL		24"	84"	29"	\$1088	\$1248	108	S	
DESCRIPTION	ITEM #	NOTES	D	W	H			SHIP WT.	LEAD TIME*
Personal Marker Board (item sold separately)	MB2318H	Marker board trim offered in Gray (8M) Magnets can be used with marker boards	1"	23"	18"	\$224		6	S

to order 1. Item Number
2. Laminate
3. Edge Finish

example **3ECH01.2439.PL - GL - FG**



ITEM NUMBER LAMINATE EDGE FINISH

please separate each item with a dot

top options (list as separate lines on your order)			paint finish options		
MODEL	DESCRIPTION	PRICE	MODEL	DESCRIPTION	LEAD TIME
3BOMC	Magnetic Clips (not to be used with side hooks)	\$82	PL	Platinum	Standard 4-6 weeks
3BODH2	Side Hooks (2) and Side Docks (2) (Offered in (PL) Platinum)	\$104			
3BODH	Side Hooks (2), Center Dock (1) and Side Docks(2) (Offered in (PL) Platinum * for use on 60"w and up)	\$104	pin height adjustable leg options		
3BODH	Back pack hooks (2)	\$82	MODEL	PRICE	
BTMP22	22" Modesty panel (to be used on a 34"w or 39"w table)	\$104		ADA Compliant 24" to 35" (Add A in front of item #)	\$230
BTMP32	32" Modesty Panel (to be used on a 48"w table)	\$122		Standing Height 28" to 41" (Add SH in front of item #)	\$230
BTMP43	43" Modesty Panel (to be used on a 60"w or 66"w table)	\$140			
BTMP55	55" Modesty Panel (to be used on a 72"w or 84"w table)	\$164			
BOF1	(1) Grommet with device holder and cupholder.	\$58			
BOF2	(2) Grommet with device holder and cupholder. (2 will fit on 24x60 or wider)	\$116			

Echo™ Series

30” deep rectangular training and teaming tables

DESCRIPTION	ITEM #	NOTES	D	W	H	Standard Laminate		SHIP WT.	LEAD TIME*
						F9 (WRITEABLE)			
						3MM EDGE	3MM EDGE		
 Echo™ 30” Deep Rectangular Training Table w/ Echo™ base & locking casters	3ECH01.3048.PL		30"	48"	29"	\$880	\$984	80	S
	3ECH01.3060.PL		30"	60"	29"	\$960	\$1084	95	S
	3ECH01.3066.PL		30"	66"	29"	\$1008	\$1150	102	S
	3ECH01.3072.PL		30"	72"	29"	\$1056	\$1200	106	S
	3ECH01.3084.PL		30"	84"	29"	\$1164	\$1328	122	S
 Echo™ 30” Deep Rectangular Training Table w/ Echo™ base, glides (1 side) & locking casters (1 side)	3ECH02.3048.PL		30"	48"	29"	\$876	\$980	80	S
	3ECH02.3060.PL		30"	60"	29"	\$946	\$1070	95	S
	3ECH02.3066.PL		30"	66"	29"	\$994	\$1136	102	S
	3ECH02.3072.PL		30"	72"	29"	\$1042	\$1186	106	S
	3ECH02.3084.PL		30"	84"	29"	\$1150	\$1314	122	S
 Echo™ 30” Deep Rectangular Training Table w/ Echo™ base & glides	3ECH03.3048.PL		30"	48"	29"	\$866	\$970	80	S
	3ECH03.3060.PL		30"	60"	29"	\$932	\$1056	95	S
	3ECH03.3066.PL		30"	66"	29"	\$982	\$1124	102	S
	3ECH03.3072.PL		30"	72"	29"	\$1030	\$1174	106	S
	3ECH03.3084.PL		30"	84"	29"	\$1138	\$1302	122	S
DESCRIPTION	ITEM #	NOTES	D	W	H	PRICE		SHIP WT.	LEAD TIME*
Personal Marker Board (item sold separately)	MB2318H	Marker board trim offered in Gray (8M) Magnets can be used with marker boards	1"	23"	18"	\$224		6	S

to order 1. Item Number
2. Laminate
3. Edge Finish

example **3ECH01.3048.PL - GL - FG**

ITEM NUMBER LAMINATE EDGE FINISH

please separate each item with a dot

top options (list as separate lines on your order)			paint finish options		
MODEL	DESCRIPTION	PRICE	MODEL	DESCRIPTION	LEAD TIME
3BOMC	Magnetic Clips (not to be used with side hooks)	\$82	PL	Platinum	Standard 4-6 weeks
3BODH2	Side Hooks (2) and Side Docks (2) (Offered in (PL) Platinum)	\$104			
3BODH	Side Hooks (2), Center Dock (1) and Side Docks(2) (Offered in (PL) Platinum * for use on 60"w and up)	\$104	pin height adjustable leg options		
3BODH	Back pack hooks (2)	\$82	MODEL	PRICE	
BTMP22	22" Modesty panel (to be used on a 34"w or 39"w table)	\$104		ADA Compliant 24" to 35" (Add A in front of item #)	\$230
BTMP32	32" Modesty Panel (to be used on a 48"w table)	\$122		Standing Height 28" to 41" (Add SH in front of item #)	\$230
BTMP43	43" Modesty Panel (to be used on a 60"w or 66"w table)	\$140			
BTMP55	55" Modesty Panel (to be used on a 72"w or 84"w table)	\$164			
BOF1	(1) Grommet with device holder and cupholder.	\$58			
BOF2	(2) Grommet with device holder and cupholder. (2 will fit on 30x60 or wider)	\$116			

Echo™ Series

Shape training and teaming tables

DESCRIPTION	ITEM #	NOTE	D	W	H	Standard Laminate	F9 (WRITEABLE)	SHIP WT.	LEAD TIME*
						3MM EDGE	3MM EDGE		
HALF ROUND									
Echo™ Half Round Training Table w/ Echo™ base & locking casters	3ECH01.2448HR.PL		24"	48"	29"	\$918	\$1022	70	S
	3ECH01.3060HR.PL		30"	60"	29"	\$1092	\$1216	95	S
Echo™ Half Round Training Table w/ Echo™ base, glides (1 side) & locking casters (1 side)	3ECH02.2448HR.PL		24"	48"	29"	\$904	\$1008	70	S
	3ECH02.3060HR.PL		30"	60"	29"	\$1076	\$1200	95	S
Echo™ Half Round Training Table w/ Echo™ base & glides	3ECH03.2448HR.PL		24"	48"	29"	\$892	\$996	70	S
	3ECH03.3060HR.PL		30"	60"	29"	\$1064	\$1188	95	S



DESCRIPTION	ITEM #	NOTES	D	W	H	PRICE	SHIP WT.	LEAD TIME*
Personal Marker Board (item sold separately)	MB2318H	Marker board trim offered in Gray (8M) Magnets can be used with marker boards	1"	23"	18"	\$224	6	S

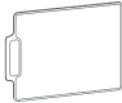

to order

- Item Number
- Laminate
- Edge Finish

example

3ECH01.2448HR.PL - GL - FG

ITEM NUMBER Laminate Edge

please separate each item with a dot

pin height adjustable leg options		paint finish options	
DESCRIPTION	PRICE	MODEL	DESCRIPTION
ADA Compliant 24" to 35" (Add "A" in front of item #)	\$230	PL	Platinum
Standing Height 28" to 41" (Add "SH" in front of item #)	\$230		

S - Standard Lead Time 4-6 weeks (Lead times subject to change without notice)

* Lead time based on paint finishes noted above / S - Standard Lead Time 4-6 weeks (Lead times subject to change without notice)

Echo™ Series

19" deep chevron training and teaming tables

DESCRIPTION	ITEM #	NOTES	D	W	H	Standard Laminate	F9 (WRITEABLE)	SHIP WT.	LEAD TIME*
						3MM EDGE	3MM EDGE		
Echo™ 19" Deep Chevron Training Table w/ Echo™ base & locking casters	3ECH04.1960.PL		19"	60"	29"	\$984	\$1078	80	S
	3ECH04.1966.PL		19"	66"	29"	\$1014	\$1120	83	S
	3ECH04.1972.PL		19"	72"	29"	\$1036	\$1146	87	S
	3ECH04.1984.PL		19"	84"	29"	\$1152	\$1282	100	S
Echo™ 19" Deep Chevron Training Table w/ Echo™ base, glides (1 side) & locking casters (1 side)	3ECH05.1960.PL		19"	60"	29"	\$972	\$1064	80	S
	3ECH05.1966.PL		19"	66"	29"	\$1002	\$1098	83	S
	3ECH05.1972.PL		19"	72"	29"	\$1022	\$1132	87	S
	3ECH05.1984.PL		19"	84"	29"	\$1138	\$1268	100	S
Echo™ 19" Deep Chevron Training Table w/ Echo™ base & glides	3ECH06.1960.PL		19"	60"	29"	\$960	\$1052	80	S
	3ECH06.1966.PL		19"	66"	29"	\$992	\$1088	83	S
	3ECH06.1972.PL		19"	72"	29"	\$1010	\$1120	87	S
	3ECH06.1984.PL		19"	84"	29"	\$1126	\$1256	100	S



DESCRIPTION	ITEM #	NOTE	D	W	H	PRICE	SHIP WT.	LEAD TIME*
Personal Marker Board (item sold separately)	MB2318H	Marker board trim offered in Gray (8M) Magnets may be used with marker boards	1"	23"	18"	\$224	6	S



to order

- Item Number
- Laminate
- Edge Finish

example

3ECH04.1960.PL - GL - FG

ITEM NUMBER Laminate Edge

please separate each item with a dot



top options (list as separate lines on your order)			pin height adjustable leg options	
MODEL	DESCRIPTION	PRICE	DESCRIPTION	PRICE
3BOMC	Magnetic Clips (not to be used with side hooks)	\$82	ADA Compliant 24" to 35" (Add "A" in front of item #)	\$230
3BOTDH2	Side Hooks (2) and Side Docks (2) (Offered in (PL) Platinum)	\$104	Standing Height 28" to 41" (Add "SH" in front of item #)	\$230
3BOTDH	Side Hooks (2), Center Dock (1) and Side Docks(2) (Offered in (PL) Platinum * for use on 60"w and up)	\$104		
3BODH	Back pack hooks (2)	\$82		
BTMP22	22" Modesty panel (to be used on a 34"w or 39"w table)	\$104		
BTMP32	32" Modesty Panel (to be used on a 48"w table)	\$122		
BTMP43	43" Modesty Panel (to be used on a 60"w or 66"w table)	\$140		
BTMP55	55" Modesty Panel (to be used on a 72"w or 84"w table)	\$164		

paint finish options		
MODEL	DESCRIPTION	LEAD TIME
PL	Platinum	Standard 4-6 weeks

S - Standard Lead Time 4-6 weeks (Lead times subject to change without notice)

Echo™ Series

24" deep chevron training & teaming tables

DESCRIPTION	ITEM #	NOTES	D	W	H	Standard Laminate	F9 (WRITEABLE)	SHIP WT.	LEAD TIME*
						3MM EDGE	3MM EDGE		
 Echo™ 24" Deep Chevron Training Table w/ Echo™ base & locking casters	3ECH04.2460.PL		24"	60"	29"	\$1004	\$1108	90	S
	3ECH04.2466.PL		24"	66"	29"	\$1036	\$1144	96	S
	3ECH04.2472.PL		24"	72"	29"	\$1088	\$1210	100	S
	3ECH04.2484.PL		24"	84"	29"	\$1174	\$1334	114	S
 Echo™ 24" Deep Chevron Training Table w/ Echo™ base, glides (1 side) & locking casters (1 side)	3ECH05.2460.PL		24"	60"	29"	\$992	\$1084	90	S
	3ECH05.2466.PL		24"	66"	29"	\$1022	\$1120	96	S
	3ECH05.2472.PL		24"	72"	29"	\$1074	\$1184	100	S
	3ECH05.2484.PL		24"	84"	29"	\$1160	\$1310	114	S
 Echo™ 24" Deep Chevron Training Table w/ Echo™ base & glides	3ECH06.2460.PL		24"	60"	29"	\$980	\$1096	90	S
	3ECH06.2466.PL		24"	66"	29"	\$1012	\$1130	96	S
	3ECH06.2472.PL		24"	72"	29"	\$1062	\$1196	100	S
	3ECH06.2484.PL		24"	84"	29"	\$1150	\$1320	114	S

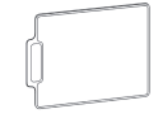
DESCRIPTION	ITEM #	NOTES	D	W	H	PRICE	SHIP WT.	LEAD TIME*
 Personal Marker Board (item sold separately)	MB2318H	Marker board trim offered in Gray (8M) Magnets may be used with marker boards	1"	23"	18"	\$224	6	S

to order



- Item Number
- Laminate
- Edge Finish

example 3ECH04.2460.PL - GL - FG
 ITEM NUMBER Laminate Edge
 please separate each item with a dot

top options (list as separate lines on your order)			pin height adjustable leg options		
MODEL	DESCRIPTION	PRICE	DESCRIPTION	PRICE	
3BOMC	Magnetic Clips (not to be used with side hooks)	\$82	ADA Compliant 24" to 35"	\$230	
3BOTDH2	Side Hooks (2) and Side Docks (2) (Offered in (PL) Platinum	\$104	(Add "A" in front of item #)		
3BOTDH	Side Hooks (2), Center Dock (1) and Side Docks(2) (Offered in (PL) Platinum * for use on 60"w and up	\$104	Standing Height 28" to 41" (Add "SH" in front of item #)	\$230	
3BODH	Back pack hooks (2)	\$82			
BTMP22	22" Modesty panel (to be used on a 34"w or 39"w table)	\$104	paint finish options		
BTMP32	32" Modesty Panel (to be used on a 48"w table)	\$122	MODEL	DESCRIPTION	LEAD TIME
BTMP43	43" Modesty Panel (to be used on a 60"w or 66"w table)	\$140	PL	Platinum	Standard 4-6 weeks
BTMP55	55" Modesty Panel (to be used on a 72"w or 84"w table)	\$164			
BOF1	(1) Grommet with device holder and cupholder.	\$58			
BOF2	(2) Grommet with device holder and cupholder. (2 will fit on 24x60 or wider)	\$116			

Echo™ Series

30" deep chevron training & teaming tables

DESCRIPTION	ITEM #	NOTES	D	W	H	Standard Laminate	F9 (WRITEABLE)	SHIP WT.	LEAD TIME*
						3MM EDGE	3MM EDGE		
 Echo™ 30" Deep Chevron Training Table w/ Echo™ base & locking casters	3ECH04.3060.PL		30"	60"	29"	\$1046	\$1170	102	S
	3ECH04.3066.PL		30"	66"	29"	\$1068	\$1210	109	S
	3ECH04.3072.PL		30"	72"	29"	\$1120	\$1264	115	S
	3ECH04.3084.PL		30"	84"	29"	\$1218	\$1382	131	S
 Echo™ 30" Deep Chevron Training Table w/ Echo™ base, glides (1 side) & locking casters (1 side)	3ECH05.3060.PL		30"	60"	29"	\$1032	\$1156	102	S
	3ECH05.3066.PL		30"	66"	29"	\$1054	\$1196	109	S
	3ECH05.3072.PL		30"	72"	29"	\$1106	\$1250	115	S
	3ECH05.3084.PL		30"	84"	29"	\$1204	\$1368	131	S
 Echo™ 30" Deep Chevron Training Table w/ Echo™ base & glides	3ECH06.3060.PL		30"	60"	29"	\$1022	\$1146	102	S
	3ECH06.3066.PL		30"	66"	29"	\$1044	\$1186	109	S
	3ECH06.3072.PL		30"	72"	29"	\$1096	\$1240	115	S
	3ECH06.3084.PL		30"	84"	29"	\$1194	\$1358	131	S

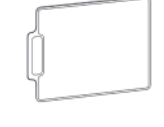
ITEM #	NOTES	D	W	H	PRICE	SHIP WT.	LEAD TIME*
 Personal Marker Board (item sold separately)	MB2318H Marker board trim offered in Gray (8M) Magnets may be used with marker boards	1"	23"	18"	\$224	6	S

to order

- Item Number
- Laminate
- Edge Finish

example 3ECH04.2460.PL - GL - FG
 ITEM NUMBER Laminate Edge
 please separate each item with a dot

top options (list as separate lines on your order)			pin height adjustable leg options		
MODEL	DESCRIPTION	PRICE	DESCRIPTION	PRICE	
3BOMC	Magnetic Clips (not to be used with side hooks)	\$82	ADA Compliant 24" to 35"	\$230	
3BOTDH2	Side Hooks (2) and Side Docks (2) (Offered in (PL) Platinum	\$104	(Add "A" in front of item #)		
3BOTDH	Side Hooks (2), Center Dock (1) and Side Docks(2) (Offered in (PL) Platinum * for use on 60"w and up	\$104	Standing Height 28" to 41" (Add "SH" in front of item #)	\$230	
3BODH	Back pack hooks (2)	\$82			
BTMP22	22" Modesty panel (to be used on a 34"w or 39"w table)	\$104	paint finish options		
BTMP32	32" Modesty Panel (to be used on a 48"w table)	\$122	MODEL	DESCRIPTION	LEAD TIME
BTMP43	43" Modesty Panel (to be used on a 60"w or 66"w table)	\$140	PL	Platinum	Standard 4-6 weeks
BTMP55	55" Modesty Panel (to be used on a 72"w or 84"w table)	\$164			
BOF1	(1) Grommet with device holder and cupholder.	\$58			
BOF2	(2) Grommet with device holder and cupholder. (2 will fit on 30x60 or wider)	\$116			

Echo™ Series

24" deep meeting tables

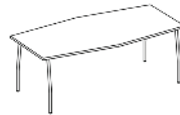
DESCRIPTION	ITEM #	NOTES	D	W	H	Standard Laminate	F9 (WRITEABLE)	SHIP WT.	LEAD TIME*
						3MM EDGE	3MM EDGE		
Echo™ 24" Deep Meeting Table w/ Echo™ base & locking casters 	3ECH07.2460.PL		24"	60"	29"	\$1078	\$1354	90	S
	3ECH07.2472.PL		24"	72"	29"	\$1152	\$1444	100	S
	3ECH07.2484.PL		24"	84"	29"	\$1248	\$1538	114	S
Echo™ 24" Deep Meeting Table w/ Echo™ base & glides 	3ECH18.2460.PL		24"	60"	29"	\$1066	\$1342	90	S
	3ECH18.2472.PL		24"	72"	29"	\$1140	\$1432	100	S
	3ECH18.2484.PL		24"	84"	29"	\$1236	\$1526	114	S

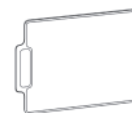
DESCRIPTION	ITEM #	NOTE	D	W	H	PRICE	SHIP WT.	LEAD TIME*
Personal Marker Board (item sold separately) 	MB2318H	Marker board trim offered in Gray (8M) Magnets may be used with marker boards	1"	23"	18"	\$224	6	S

to order

- Item Number
- Laminate
- Edge Finish

example **3ECH07.2460.PL - GL - FG**
ITEM NUMBER Laminate Edge
 please separate each item with a dot

top options (list as separate lines on your order)			pin height adjustable leg options		
MODEL	DESCRIPTION	PRICE	DESCRIPTION	PRICE	
3BOTDH2	Side Hooks (2) and Side Docks (2) Offered in (PL) Platinum	ADD \$104	ADA Compliant 24" to 35" (Add "A" in front of item #)	\$230	
			Standing Height 28" to 41" (Add "SH" in front of item #)	\$230	
paint finish options					
MODEL	DESCRIPTION	LEAD TIME			
PL	Platinum	Standard 4-6 weeks			

S - Standard Lead Time 4-6 weeks (Lead times subject to change without notice)

Echo™ Series

30" deep meeting tables

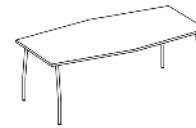
DESCRIPTION	ITEM #	NOTES	D	W	H	Standard Laminate	F9 (WRITEABLE)	SHIP WT.	LEAD TIME*
						3MM EDGE	3MM EDGE		
Echo™ 30" Deep Meeting Table w/ Echo™ base & locking casters 	3ECH07.3060.PL		30"	60"	29"	\$1142	\$1418	102	S
	3ECH07.3072.PL		30"	72"	29"	\$1232	\$1524	115	S
	3ECH07.3084.PL		30"	84"	29"	\$1344	\$1634	131	S
Echo™ 30" Deep Meeting Table w/ Echo™ base & glides 	3ECH18.3060.PL		30"	60"	29"	\$1130	\$1406	102	S
	3ECH18.3072.PL		30"	72"	29"	\$1220	\$1512	115	S
	3ECH18.3084.PL		30"	84"	29"	\$1332	\$1622	131	S

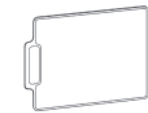
DESCRIPTION	ITEM #	NOTE	D	W	H	PRICE	SHIP WT.	LEAD TIME*
Personal Marker Board (item sold separately) 	MB2318H	Marker board trim offered in Gray (8M) Magnets may be used with marker boards	1"	23"	18"	\$224	6	S

to order

- Item Number
- Laminate
- Edge Finish

example **3ECH07.2460.PL - GL - FG**
ITEM NUMBER Laminate Edge
 please separate each item with a dot

top options (list as separate lines on your order)			pin height adjustable leg options		
MODEL	DESCRIPTION	PRICE	DESCRIPTION	PRICE	
3BOTDH2	Side Hooks (2) and Side Docks (2) (Offered in (PL) Platinum)	ADD \$104	ADA Compliant 24" to 35" (Add "A" in front of item #)	\$230	
			Standing Height 28" to 41" (Add "SH" in front of item #)	\$230	
paint finish options					
MODEL	DESCRIPTION	LEAD TIME			
PL	Platinum	Standard 4-6 weeks			

S - Standard Lead Time 4-6 weeks (Lead times subject to change without notice)

Echo™ Series

easel & marker boards

DESCRIPTION	ITEM #	NOTE	D	W	H	PRICE	SHIP WT.	LEAD TIME*
Echo™ 2-sided easel with center storage on casters. Holds 16 boards on the outside (8 per side) and stores an additional 24 on the inside. Tray for markers on top. Marker boards quoted and sold specialty.	ECEASEL.PL	Unit holds 16 marker boards (8 per side) Unit holds an additional 24 boards on the inside	26.5"	40"	61"	\$1840	200	S



DESCRIPTION	ITEM #	NOTE	D	W	H	PRICE	SHIP WT.	LEAD TIME*
Personal Marker Board (item sold separately)	MB2318H	Marker board trim offered in Gray (8M) Magnets may be used with marker boards	1"	23"	18"	\$224	6	S

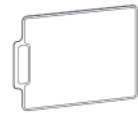

DESCRIPTION	ITEM #	NOTE	D	W	H	PRICE	SHIP WT.	LEAD TIME*
Echo™ wall mount rail for marker boards	WALLMB-42	Holds 2 marker boards – 42" w when boards are mounted		42.35"	1.9"	\$224	7	S
	WALLMB-60	Holds 3 marker boards-60" w when boards are mounted		60.5"	1.9"	\$284	8	S



DESCRIPTION	ITEM #	NOTE	D	W	H	PRICE	SHIP WT.	LEAD TIME*
	WALLMB-72	Holds 4 marker boards-72" w when boards are mounted		72.5"	1.9"	\$344	8	S



to order	1. Item Number	ECEASEL.PL
		ITEM NUMBER

example

paint finish options

MODEL	DESCRIPTION	LEAD TIME
PL	Platinum	Standard 4-6 weeks

S - Standard Lead Time 4-6 weeks (Lead times subject to change without notice)

Echo™ Series

mobile educators podium desk

DESCRIPTION	ITEM #	D	W	H	3MM EDGE	SHIP WT.	LEAD TIME*
Echo™ Mobile Podium Educators Desk-24"d x 54"w x 29"h non-handed desk, Echo™ base, magnetic clip and 24"d x 17"w x 42"h podium. Platinum finish.	PEDES2454C-M.PL	24"	71"	29"/42"	\$2996	300	S



Echo™ Mobile Podium Educators Desk-24"d x 60"w x 29"h non-handed desk, Echo™ base, magnetic clip and 24"d x 17"w x 42"h podium. Platinum finish.	PEDES2460C-M.PL	24"	77"	29"/42"	\$3010	325	S
--	-----------------	-----	-----	---------	--------	-----	---



Mobile Educators Podium with casters	LCT03	24"	17"	42"	\$1998	92	E
--------------------------------------	-------	-----	-----	-----	--------	----	---



to order	1. Item Number	PEDES2454C-M.PL	-	GL	-	FG
	2. Laminate	ITEM NUMBER		Laminate		Edge
	3. Edge Finish					

please separate each item with a dot

example

top options (list as separate lines on your order)

MODEL	DESCRIPTION	PRICE
BTMP32	32" Modesty Panel (to be used on a 54"w table)	\$122
BTMP43	43" Modesty Panel (to be used on a 60"w or 66"w table)	\$140

paint finish options

MODEL	DESCRIPTION	LEAD TIME
PL	Platinum	Standard 4-6 weeks

S - Standard Lead Time 4-6 weeks (Lead times subject to change without notice)

Echo™ Series

mobile teacher's desk

DESCRIPTION	ITEM #	D	W	H	3MM EDGE	SHIP WT.	LEAD TIME*
-------------	--------	---	---	---	----------	----------	------------

Echo™ Mobile Teacher's Desk 24" x 54" with Box/Box/File mobile pedestal, Echo™ legs and modesty panel



Echo™ Mobile Teacher's Desk 24" x 60" with Box/Box/File mobile pedestal, Echo™ legs and modesty panel



ECTD.2454.PL	24"	54"	29"	\$1554	99	S
ECTD.2460.PL	24"	60"	29"	\$1608	107	S

Ethos Series

introduction



General

Flexible seating solutions complete the Haskell lineup of education products for a clean, consistent look; meet the demands of K–12, higher education and corporate training facilities. Designed for 21st Century Learning, Haskell seating supports dynamic classrooms where the physical environment responds to the curriculum; smoothly transitioning from lectures to collaborative activities and back, becoming a platform for active learning.

More than a chair, Ethos doubles as an active learning platform for twenty-first century pedagogy. An agile storage base plus classic seat shell, Ethos blends flexibility (like 360-degree swiveling capability and an ambidextrous worksurface) with mobility and personal storage. Haskell's seating design anticipates the needs of today's vibrant classroom, a classroom that transitions seamlessly from **lectures** to **group work** and **discussion** groups.

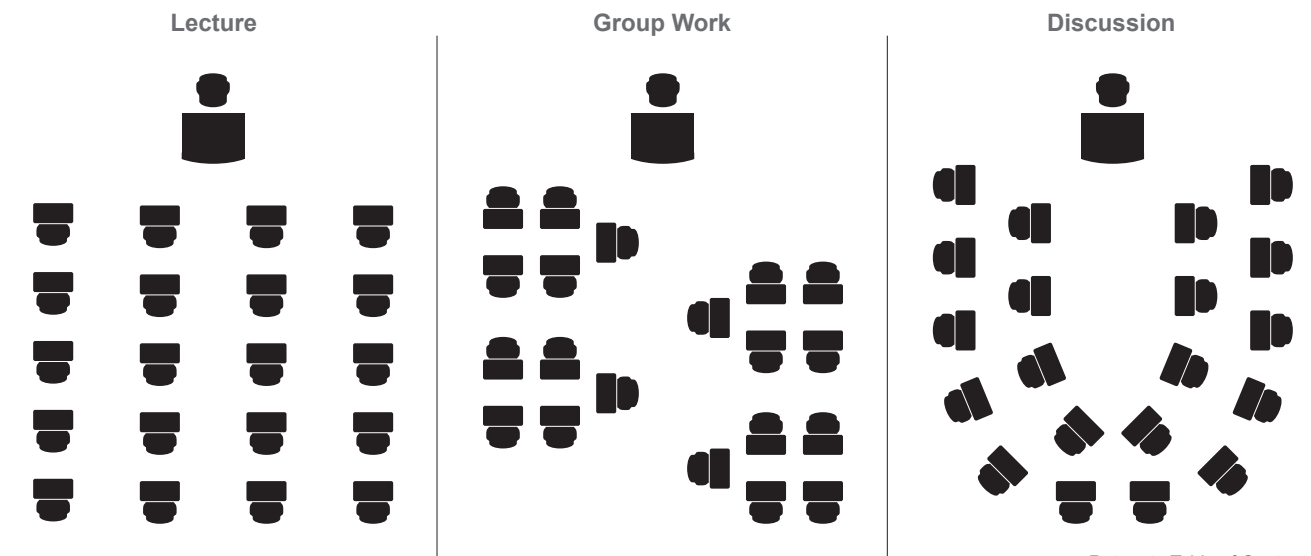

to order

- Item Number
- Laminate
- Edge Finish

example

ECTD.2454.PL - GL - FG

ITEM NUMBER Laminate Edge

please separate each item with a dot

paint finish options

MODEL	DESCRIPTION	LEAD TIME
PL	Platinum	Standard 4-6 weeks

S - Standard Lead Time 4-6 weeks (Lead times subject to change without notice)

Ethos Series

product specifications

Statement of Line

Chairs and stools are available with molded polypropylene fiberglass reinforced shells. Chairs are available with a storage base, storage base with worksurface, five-star base with pneumatic adjustment. Stools are available with five-star base only.

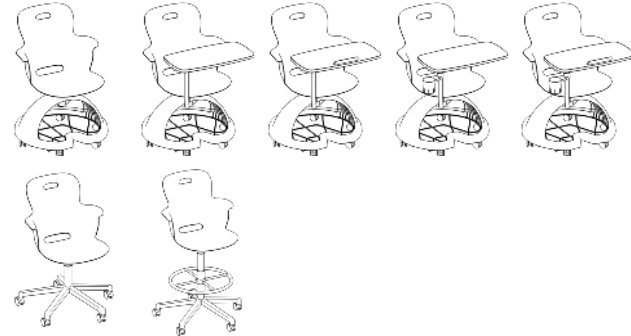

Base

The Storage base offers generous access and fully utilizes the space under the seat. The space easily accommodates large backpacks and other personal belongings and is comfortable as a footrest. The storage base comes standard with a two-toned finish. The five-star base is an option when storage is not needed.

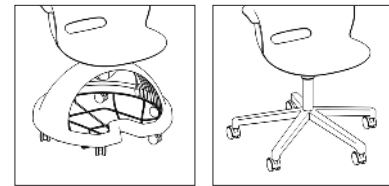

Worksurface

Worksurface is non handed and can swivel completely right and left to accommodate both right and left handed users. It is 12.5"D x 23.25"W to allow for space for both books and technology.

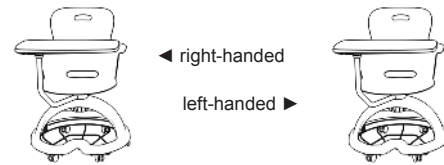

360° Swivel

360° fixed height swivel mechanism on quad base models allows students to adjust their orientation to focus on the instructor, presentation materials, and other students as needed. 360° adjustable height swivel mechanism is standard on five-star base models.



Pneumatic Five-Star Base

Seat height adjusts pneumatically. To lower, pull lever up while seated. To raise, pull lever up and keep your weight off the chair. Range of adjustability is 5" from 16"H to 21"H, a 3 3/4" range (17 1/4"H to 21"H) is available on chairs with a worksurface. Stools are standard with a 7" range of adjustability (23 1/2"H to 30 1/2"H).

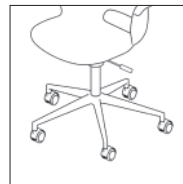

Cup Holder

Cup holder is available as an option on Ethos chairs with tablet worksurfaces.

Shipping & Assembly

The Ethos Series, including the quad, metal and five- star bases, with or without worksurface, ships standard unassembled with the seat shell separated from the base. Assembly by a qualified Haskell dealer and/or installer is recommended. No tools required for assembly.

Testing

Ethos meets or exceeds ANSI/BIFMA testing standards.

Measurements

C Shell			
OUTSIDE ARM	INSIDE ARM	SEAT WIDTH	DEPTH FRONT TO
23 1/2"	19 1/2"	18 1/4"	16 3/4"

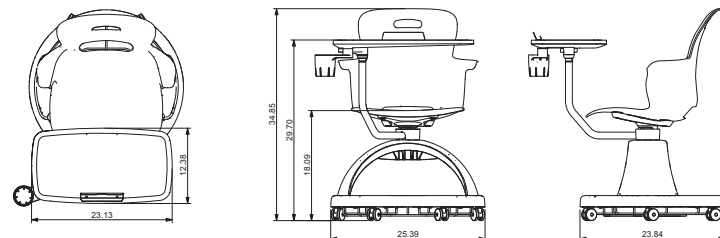

Ethos Series

18" storage base

DESCRIPTION	ITEM #	NOTES	D	W	H	PRICE	SHIP WT.	LEAD TIME*
Storage base, easy grip handle in shell. Specify casters.	2ES1C0	hard wheel casters for carpeted surfaces	24 1/2"	22 7/8"	34 1/2"	\$548	27	S
	2ES1CSW0	soft wheel casters for hard surfaces	24 1/2"	22 7/8"	34 1/2"	\$590	27	S
Storage base, articulating/telescoping work surface with pencil rim, easy grip handle in shell. Specify casters.	2ES1C1	hard wheel casters for carpeted surfaces	31 7/8"	23 1/4"	34 1/2"	\$808	36.5	S
	2ES1CSW1	soft wheel casters for hard surfaces work surface support arm in platinum (PL)	31 7/8"	23 1/4"	34 1/2"	\$850	36.5	S
Storage base, articulating/telescoping work surface with pencil rim, cup holder, easy grip handle in shell. Specify casters.	2ES1C2	hard wheel casters for carpeted surfaces	31 7/8"	23 1/4"	34 1/2"	\$850	36.5	S
	2ES1CSW2	soft wheel casters for hard surfaces work surface support arm in platinum (PL)	31 7/8"	23 1/4"	34 1/2"	\$892	36.5	S
Storage base, articulating/telescoping work surface with pencil rim and right handed tablet holder, easy grip handle in shell. Specify casters.	2ES1C3	hard wheel casters for carpeted surfaces	31 7/8"	23 1/4"	34 1/2"	\$838	36.5	S
	2ES1CSW3	soft wheel casters for hard surfaces work surface support arm in platinum (PL)	31 7/8"	23 1/4"	34 1/2"	\$880	36.5	S
Storage base, articulating/telescoping work surface with pencil rim and right handed tablet holder, cup holder, easy grip handle in shell. Specify casters.	2ES1C4	hard wheel casters for carpeted surfaces	31 7/8"	23 1/4"	34 1/2"	\$886	36.5	S
	2ES1CSW4	soft wheel casters for hard surfaces work surface support arm in platinum (PL)	31 7/8"	23 1/4"	34 1/2"	\$928	36.5	S

- to order
- Item Number (replace xx with caster option where applicable)
 - Shell Finish
 - Base Finish
 - Tablet Finish (where applicable)

example

2ES1C1	-	8A	-	8L	-	8M
ITEM NUMBER		SHELL FINISH		BASE FINISH		TABLET FINISH
						Only option

please separate each item with a dash

shell finish options

CODE	DESCRIPTION
8A	Black
8B	Red
8D	Sky
8E	Green Apple
8F	Orange
8I	Purple
8J	Navy
8L	Storm

base finish options

CODE	DESCRIPTION
8L	Storm Base / Platinum Metal Storage Basket
8A	Black Base / Platinum Metal Storage Basket





work surface finish

CODE	DESCRIPTION
8M	Gray (Only option)

* S - Standard Lead Time 4-6 weeks (Lead times subject to change without notice)

Ethos Series

18" storage base with glides

DESCRIPTION	ITEM #	NOTES	D	W	H	PRICE	SHIP WT.	LEAD TIME*
Storage base, easy grip handle in shell, glides 	2ES1G0		24 1/2"	22 7/8"	34 1/2"	\$582	27	S
Storage base, articulating/telescoping work surface with pencil rim, easy grip handle in shell, glides 	2ES1G1	work surface support arm in platinum (PL)	31 7/8"	23 1/4"	34 1/2"	\$838	36.5	S
Storage base, articulating/telescoping work surface with pencil rim, cup holder, easy grip handle in shell, glides. 	2ES1G2	work surface support arm in platinum (PL)	31 7/8"	23 1/4"	34 1/2"	\$876	36.5	S
Storage base, articulating/telescoping work surface with pencil rim and tablet holder, easy grip handle in shell, glides 	2ES1G3	work surface support arm in platinum (PL)	31 7/8"	23 1/4"	34 1/2"	\$886	36.5	S
Storage base, articulating/telescoping work surface with pencil rim and tablet holder, cup holder, easy grip handle in shell, glides. 	2ES1G4	work surface support arm in platinum (PL)	31 7/8"	23 1/4"	34 1/2"	\$908	36.5	S

to order

- Item Number (replace xx with caster option where applicable)
- Shell Finish
- Base Finish
- Tablet Finish (where applicable)

example 2ES1C0HW - 8A - SP - 8M

ITEM NUMBER	SHELL FINISH	BASE FINISH	TABLET FINISH Only option
2ES1C0HW	8A	SP	8M

please separate each item with a dash

shell finish options

CODE	DESCRIPTION	LEAD TIME
8A	Black	Standard 4-6 weeks
8B	Red	Standard 4-6 weeks
8D	Sky	Standard 4-6 weeks
8E	Green Apple	Standard 4-6 weeks
8F	Orange	Standard 4-6 weeks
8I	Purple	Standard 4-6 weeks
8J	Navy	Standard 4-6 weeks
8L	Storm	Standard 4-6 weeks

base finish options



CODE	DESCRIPTION
8L	Storm Base / Platinum Metal Storage Basket
8A	Black Base / Patinum Metal Storage Basket

work surface finish

CODE	DESCRIPTION
8M	Gray (Only option)

Ethos Series

five star base

DESCRIPTION	ITEM #	NOTES	D	W	H	PRICE	SHIP WT.	LEAD TIME*
Five star base, easy grip handle in shell. Specify casters. 	2ES2C0	hard wheel casters for carpeted surfaces	23 3/4"	23 3/4"	32 1/2" - 37 1/2"	\$510	33	S
	2ES2CSW0	soft wheel casters for hard surfaces pneumatic range 16" - 21"	23 3/4"	23 3/4"	32 1/2" - 37 1/2"	\$552	33	S
Five star base, easy grip handle in shell, glides 	2ES2G0	pneumatic range 16" - 21"	23 3/4"	23 3/4"	32 1/2" - 37 1/2"	\$538	33	S

to order

- Item Number (replace xx with caster option where applicable)
- Shell Finish
- Base Finish

example 2ES2C0HW - 8E - 8A

ITEM NUMBER	SHELL FINISH	BASE FINISH Only Option
2ES2C0HW	8E	8A

please separate each item with a dash

shell finish options

CODE	DESCRIPTION	LEAD TIME
8A	Black	Standard 4-6 weeks
8B	Red	Standard 4-6 weeks
8D	Sky	Standard 4-6 weeks
8E	Green Apple	Standard 4-6 weeks
8F	Orange	Standard 4-6 weeks
8I	Purple	Standard 4-6 weeks
8J	Navy	Standard 4-6 weeks
8L	Storm	Standard 4-6 weeks

base finish

CODE	DESCRIPTION	LEAD TIME
8A	Black Only Option	Standard 4-6 weeks

Ethos Series

stool height

DESCRIPTION	ITEM #	NOTES	D	W	H	PRICE	SHIP WT.	LEAD TIME*
Five star base, stool height, easy grip handle in shell. Specify casters	2ES4C0	hard wheel casters for carpeted surfaces	22 1/4"	23 3/4"	40" - 47"	\$724	38	S
	2ES4CSW0	soft wheel casters for hard surfaces	22 1/4"	23 3/4"	40" - 47"	\$766		
Five star base, stool height, easy grip handle in shell, glides	2ES4G0	pneumatic range 23.5" - 30.5" footring offered in black (BA)	22 1/4"	23 3/4"	40" - 47"	\$750	38	S

Explorer Series®

introduction - tables



ROVER® TABLE



ROVER® TABLE



MAKER TABLE

General

The makerspace movement is becoming a powerful part of many school district curriculums. Schools are repurposing classrooms, renovating computer labs, and retooling media centers to accommodate the tools required for these creative spaces. To help foster and grow these new creative spaces, Haskell created The Rover® Table and Explorer Series®. It is a collection of innovative makerspace solutions to help schools create engaging and functional spaces while catering to the needs of these unique creative areas.

Engineered to be easily transported across the hall or across the district, the Rover® Table is the ideal solution for a shared maker curriculum.

The Explorer Maker Table by Haskell has been designed to meet the demanding needs of these creative environments.

to order

1. Item Number (replace xx with caster option where applicable)
2. Shell Finish
3. Base Finish

example 2ES4C0HW - 8A - 8A

ITEM NUMBER	SHELL FINISH	BASE FINISH
		Only Option

please separate each item with a dash

shell finish options			base finish		
CODE	DESCRIPTION	LEAD TIME	CODE	DESCRIPTION	LEAD TIME
8A	Black	Standard 4-6 weeks	8A	Black	Standard 4-6 weeks
8B	Red	Standard 4-6 weeks		Only Option	
8D	Sky	Standard 4-6 weeks			
8E	Green Apple	Standard 4-6 weeks			
8F	Orange	Standard 4-6 weeks			
8I	Purple	Standard 4-6 weeks			
8J	Navy	Standard 4-6 weeks			
8L	Storm	Standard 4-6 weeks			

Explorer Series®

rover® table specifications

OVERALL DIMENSIONS

Table
84x42x36.5
Mobile
84x29.5x50.5

TOP
Top Dimension: 84x42x1.5in
- Solid Birch Butcher Block

MECHANISM & LATCH

Mechanism
- Proprietary 4-bar linkage flip-top mechanism
- Gas assist
- Single user actuation

Latch
- 2 Independent lever actuated rotary latch locks
800lb load rating (each)

BASE

Construction
- Welded Steel Tube
50mm O.D., 3mm wall
- 18 Gauge Formed and Welded Steel

Foot

- Material: Nylon

CASTERS

4 - 4" Locking Directional Total Lock
- High Strength Steel
- TPU Tread, Non-Marking
- Corrosion Resistant
- 300lb load rating (per caster)

POWER (OPTIONAL)

In Surface Power Unit
- Manufacturer : Byrne
- 3 110v Power, 2 USB
- Integrated Circuit Breaker
Rating
- 13 amps, 125 volts

Cord (Provided)

- NEMA 5-15, 14 AWG, 3 Conductor,
- 15 Amp, 10 foot

SPECIFICATIONS

Max Load
- TBD
Paint
- Textured Powder coat

MODULE OPTIONS*

Module Configuration
- 2 Bin storage modules

*Refer to module specifications for more information

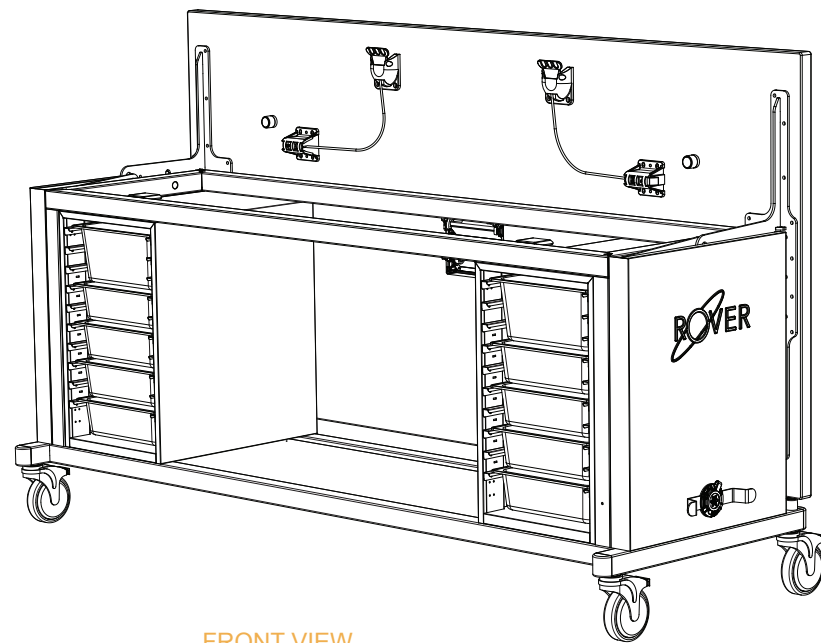

FRONT VIEW

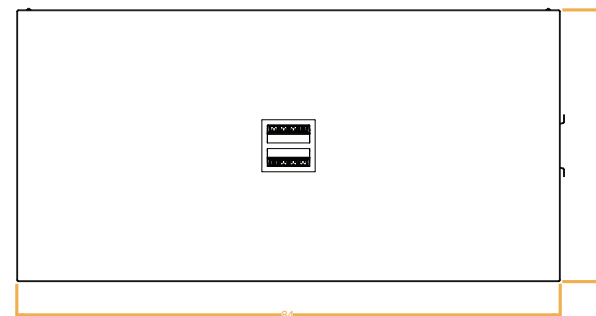

TOP VIEW

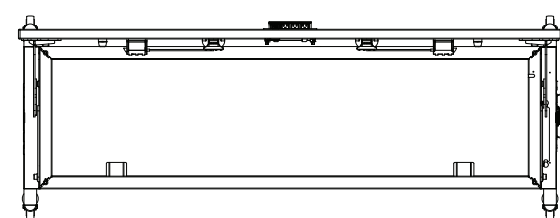

SIDE VIEWS

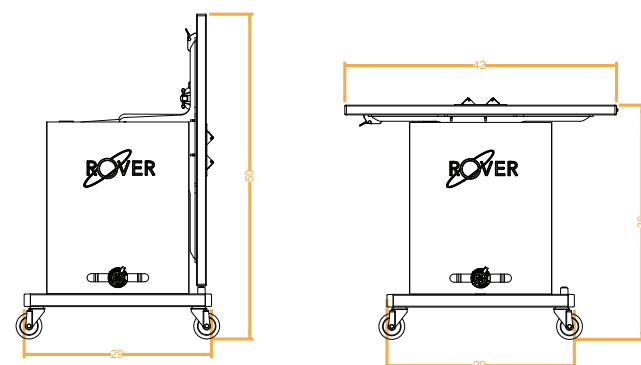

Explorer Series®

rover® table configuration

Rover® Table Module Configuration

The Rover® Table can be configured to fit the needs of your classroom or makerspace. Seven different modules are available and include open and secured storage modules, peg boards for hanging supplies like 3d printing filament, and double-wide storage modules for larger projects. You can create your own custom configuration using the information below when ordering.

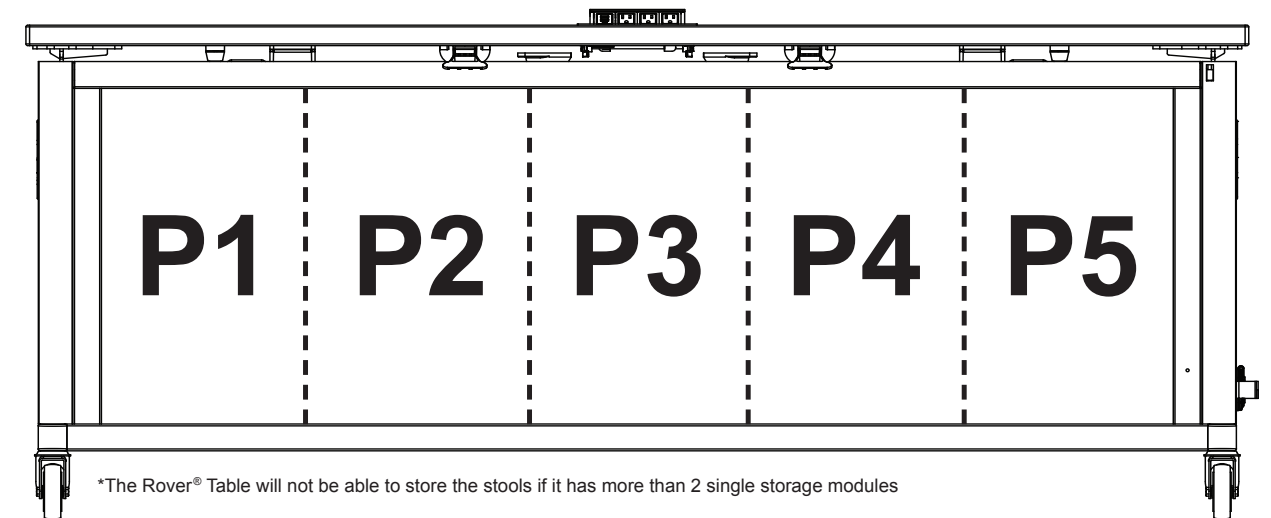

*The Rover® Table will not be able to store the stools if it has more than 2 single storage modules

One Position Storage Modules

These storage modules use open position in the Maker Table

Bin Storage Module
BINSM

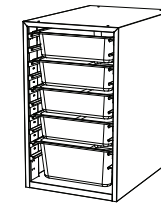

Single Storage Module*
SGLSM

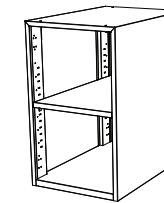

Single Storage Module with Locking Door*
SGLSMD

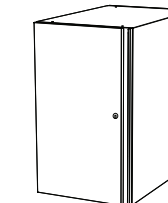

Peg Board Module
PEGSM

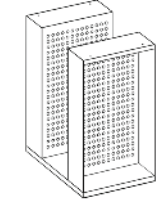

Tool Storage Module*
TOOLSM

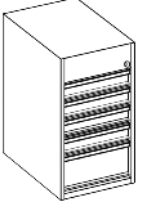

Two Position Storage Modules

These storage modules use two positions side-by-side.

Double Storage Module
DBLSM

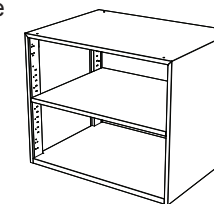



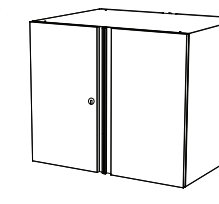

Double Storage Module with Locking Doors
DBLSMD



Get Started with a Pre-Configured Rover® Table, or Configure Your Own!

Explorer Series®

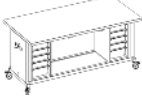
rover® table configured

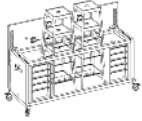
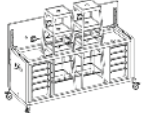
DESCRIPTION	ITEM #	D	W	H	PRICE	SHIP WT.	LEAD TIME*
Rover Table 3 Module with butcher block retractable top, 4 stools and locking casters. Platinum frame only	RV1Sxxx.4260	42"/29.5"	60"/60"	36.5"/50.5"	\$6788	368	S
							
Rover Table 3 Module with butcher block retractable top, power unit with 8ft extension cord, 4 stools and locking casters. Platinum frame only	RV1SExxx.4260	42"/29.5"	60"/60"	36.5"/50.5"	\$8142	373	S
							
Rover® Table with butcher block retractable top, bin storage modules with bins and locking casters	RV1BxxxB.4284	42"/29.5"	84"/84"	36.5"/50.5"	\$7958	386	S
							
Rover® Table with butcher block retractable top, bin storage modules with bins, power unit with 8ft extension cord and locking casters	RV1EBxxxB.4284	42"/29.5"	84"/84"	36.5"/50.5"	\$9312	391	S
							
Rover® Table with butcher block retractable top, 2 bin storage modules with bins, 6 stools and locking casters	RV1SBxxxB.4284	42"/29.5"	84"/84"	36.5"/50.5"	\$9362	428	S
							
Rover® Table with butcher block retractable top, 2 bin storage modules with bins, 6 stools, power unit with 8ft extension cord and locking casters	RV1SEBxxxB.4284	42"/29.5"	84"/84"	36.5"/50.5"	\$10716	433	S
							

to order

- Item Number
- Paint Finish

See paint finish options for frame below

example RV1BxxxB.4284 - GA

ITEM NUMBER PAINT FINISH

please separate each item with a dash

paint finish options for frame

MODEL	DESCRIPTION
GA	Green Apple
EN	Navy
P2	Platinum

to order additional bins

MODEL	DESCRIPTION	PRICE
BINPK46	Clear Tote Bin Pack - Four - 4"H x 20.875"L x 12.74"W and One - 6"H x 20.875"L x 12.74"W	\$274
BINPK4	Clear Tote Bin - 4"H x 20.875"L x 12.74"W Pack of 6	\$308
BINPK6	Clear Tote Bin - 6"H x 20.875"L x 12.74"W Pack of 6	\$412



Note: Rover® ships partially assembled: top, casters, end panels need to be assembled onsite.

Freight Class 150 Origin zip 49548

* S – Standard Lead Time 4-6 weeks

Explorer Series®

rover® stool

DESCRIPTION	ITEM #	D	W	H	PRICE	SHIP WT.	LEAD TIME*
Rover® 4 legged, 16ga steel stackable stool. 13"x13" seat. Sold as a set of 3. Textured platinum only.	RVSTOOL-PL	16.5"	16.5"	25"	\$702	42	S
							
Rover 4 legged, 16ga steel stackable stool. 13"x13" seat. Priced each. Textured platinum only	RVSTOOL1-P2	16.5"	16.5"	25"	\$234	14	S
							

to order

- Select Item Number

example RVSTOOL - P2

ITEM NUMBER

Freight Class 150 Origin zip 49548

* S – Standard Lead Time 4-6 weeks

Explorer Series®

rover® table - build your own

DESCRIPTION	ITEM #	D	W	H	PRICE	SHIP WT.	LEAD TIME*
Rover Table 3 Module with butcher block retractable top and locking casters, Add up to 3 storage modules, sold separately. Platinum frame only	RV1xxx.4260	42"/29.5"	60"/60"	36.5"/50.5"	\$5852	312	S
Rover Table 3 Module with butcher block retractable top, power unit with 8ft extension cord and locking casters. Add up to 3 storage modules, sold separately. Platinum frame only	RV1Exxx.4260	42"/29.5"	60"/60"	36.5"/50.5"	\$7206	317	S
Rover® Table with butcher block retractable top and locking casters, Add up to 5 storage modules, sold separately.	RV1xxxx.4284	42"/29.5"	84"/84"	36.5"/50.5"	\$6142	312	S

to order How to Build Your Own item number

Replace "x" with storage module item number listed below. Leave "x" for empty modules (positions are laid out left to right)

example (bin storage module, single storage module without doors, ped board module, double storage module with locking doors)

MK1 or MK1E

- Position 1
- Position 2
- Position 3
- Position 4
- Position 5

B S P D 2

P1 P2 P3 P4 P5

Configurations: Five 14.7"W Modules
Two 29.4"W Modules + One 14.7"W Module
One 29.4"W Module + Three 14.7"W Modules
29.4"W Modules use 2 positions

to order 1. Item Number
2. Paint Finish

See paint finish options for frame below

example **RV1BSPD2.4284 - GA**

ITEM NUMBER PAINT FINISH

please separate each item with a dash

storage modules platinum finish only

MODEL	DESCRIPTION	PRICE	SHW WT
B = BINSM	Bin Storage Module- 14.7"W x 21.75"D x 24.5"H with clear tote bin pack Four - 4"H x 20.875"L x 12.74"W and One - 6"H x 20.875"L x 12.74"W	\$908	37
S = SGLSM	Single Storage Module without door- 14.7"W x 21.75"D x 24.5"H	\$554	38
D = SGLSMD	Single Storage Module w/ locking door - 14.7"W x 21.75"D x 24.5"H	\$758	49
P = PEGSM	Peg Board Module - 14.7"W x 21.75"D x 24.5"H (Doesn't include pegs or spools)	\$648	31
T = TOOLSM	Tool Storage Module - 14.7"W x 21.75"D x 24.5"H	\$1098	
S2 = DBLSM (uses 2 positions)	Double Storage Module without doors - 29.4"W x 21.75"D x 24.5"H	\$838	50
D2 = DBLSMD (uses 2 positions)	Double Storage Module w/ locking doors - 29.4"W x 21.75"D x 24.5"H	\$1282	71

to order additional bins

MODEL	DESCRIPTION	PRICE	BINSM	DBLSM
BINPK46	Clear Tote Bin Pack - Four - 4"H x 20.875"L x 12.74"W and One - 6"H x 20.875"L x 12.74"W	\$274		
BINPK4	Clear Tote Bin - 4"H x 20.875"L x 12.74"W Pack of 6	\$308		
BINPK6	Clear Tote Bin - 6"H x 20.875"L x 12.74"W Pack of 6	\$412		

paint finish options for frame

MODEL	DESCRIPTION	SGLSMD	PEGSM
GA	Green Apple		
EN	Navy		
P2	Textured Platinum		

Note: Maker tables ship KD: Storage modules are shipped assembled except doors need to be attached onsite when applicable.
Freight Class 150 Origin zip 49548
* S - Standard Lead Time 4-6 weeks

Explorer Series®

rover® table - build your own

DESCRIPTION	ITEM #	D	W	H	PRICE	SHIP WT.	LEAD TIME*
Rover® Table with butcher block retractable top, power unit with 8ft extension cord and locking casters. Add up to 5 storage modules, sold separately.	RV1Exxxxx.4284	42"/29.5"	84"/84"	36.5"/50.5"	\$7496	317	S
Rover Table with butcher block retractable top, 6 stools and locking casters. Add up to 5 storage modules, sold separately.	RV1Sxxxx.4284	42"/29.5"	84"/84"	36.5"/50.5"	\$7546	354	S
Rover Table with butcher block retractable top, 6 stools, power unit with 8ft extension cord and locking casters. Add up to 5 storage modules, sold separately.	RV1SExxxx.4284	42"/29.5"	84"/84"	36.5"/50.5"	\$8900	359	S

to order How to Build Your Own item number

Replace "x" with storage module item number listed below. Leave "x" for empty modules (positions are laid out left to right)

example (bin storage module, single storage module without doors, ped board module, double storage module with locking doors)

MK1 or MK1E

- Position 1
- Position 2
- Position 3
- Position 4
- Position 5

B S P D 2

P1 P2 P3 P4 P5

Configurations: Five 14.7"W Modules
Two 29.4"W Modules + One 14.7"W Module
One 29.4"W Module + Three 14.7"W Modules
29.4"W Modules use 2 positions

to order 1. Item Number
2. Paint Finish

See paint finish options for frame below

example **RV1BSPD2.4284 - GA**

ITEM NUMBER PAINT FINISH

please separate each item with a dash

storage modules platinum finish only

MODEL	DESCRIPTION	PRICE	SHW WT
B = BINSM	Bin Storage Module- 14.7"W x 21.75"D x 24.5"H with clear tote bin pack Four - 4"H x 20.875"L x 12.74"W and One - 6"H x 20.875"L x 12.74"W	\$908	37
S = SGLSM	Single Storage Module without door- 14.7"W x 21.75"D x 24.5"H	\$554	38
D = SGLSMD	Single Storage Module w/ locking door - 14.7"W x 21.75"D x 24.5"H	\$758	49
P = PEGSM	Peg Board Module - 14.7"W x 21.75"D x 24.5"H (Doesn't include pegs or spools)	\$648	31
T = TOOLSM	Tool Storage Module - 14.7"W x 21.75"D x 24.5"H	\$1098	
S2 = DBLSM (uses 2 positions)	Double Storage Module without doors - 29.4"W x 21.75"D x 24.5"H	\$838	50
D2 = DBLSMD (uses 2 positions)	Double Storage Module w/ locking doors - 29.4"W x 21.75"D x 24.5"H	\$1282	71

to order additional bins

MODEL	DESCRIPTION	PRICE	BINSM	DBLSM
BINPK46	Clear Tote Bin Pack - Four - 4"H x 20.875"L x 12.74"W and One - 6"H x 20.875"L x 12.74"W	\$274		
BINPK4	Clear Tote Bin - 4"H x 20.875"L x 12.74"W Pack of 6	\$308		
BINPK6	Clear Tote Bin - 6"H x 20.875"L x 12.74"W Pack of 6	\$412		

paint finish options for frame

MODEL	DESCRIPTION	SGLSMD	PEGSM
GA	Green Apple		
EN	Navy		
P2	Textured Platinum		

Note: Maker tables ship KD: Storage modules are shipped assembled except doors need to be attached onsite when applicable.
Freight Class 150 Origin zip 49548
* S - Standard Lead Time 4-6 weeks

Explorer Series®

maker table configuration

Maker Table Module Configuration

The Maker Table can be configured to fit the needs of your classroom or makerspace. Six different modules are available and include open and secured storage modules, peg boards for hanging supplies like 3d printing filament, and double-wide storage modules for larger projects. A large number of pre-configured Maker Tables are provided on the next few pages. You can also create your own custom configuration using the information below when ordering.

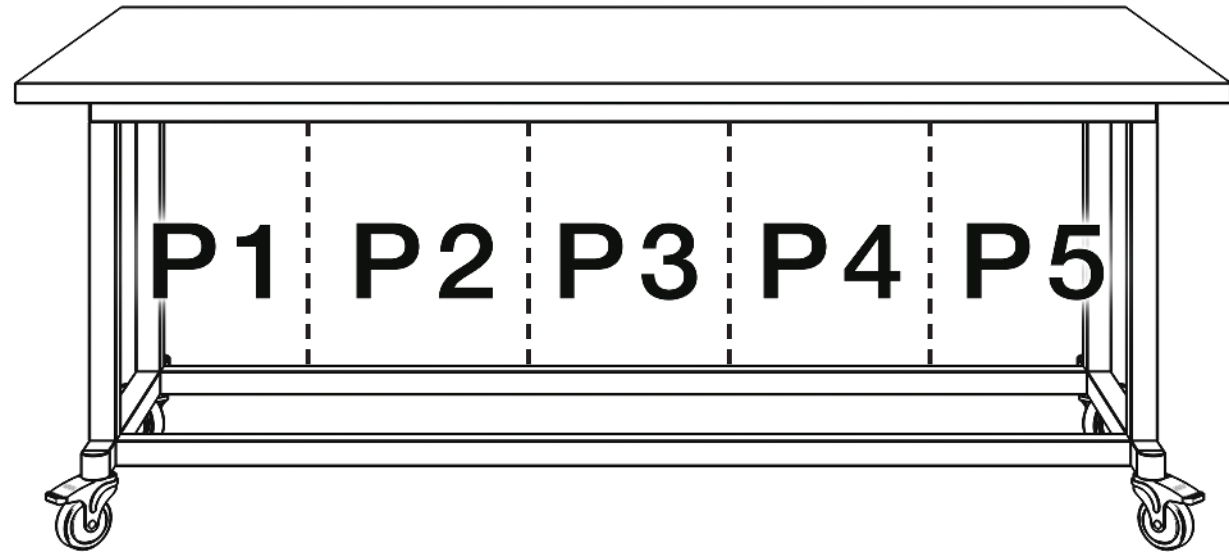

One Position Storage Modules

These storage modules use open position in the Maker Table

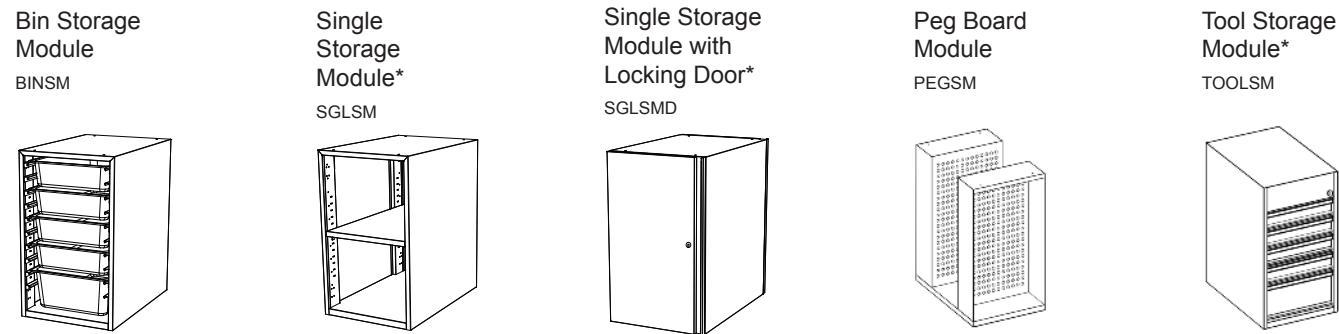

Two Position Storage Modules

These storage modules use two positions side-by-side.

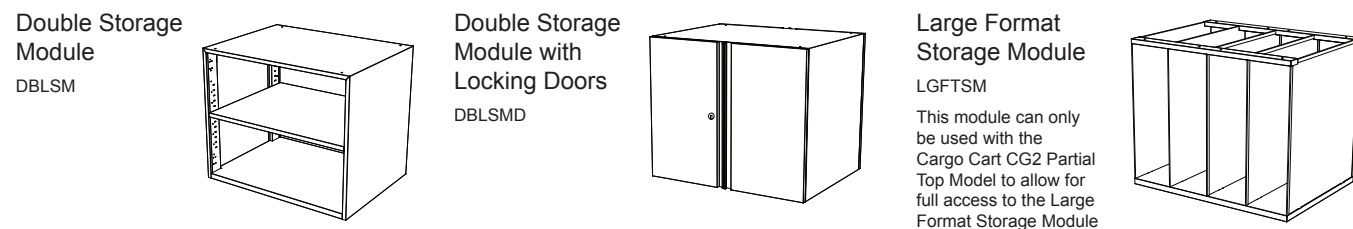

Get Started with a Pre-Configured Maker Table, or Configure Your Own!

*When specifying the single storage module or the tool storage module, you cannot specify five of these modules in a row within the frame of the Maker Table.

Explorer Series®

maker table specifications

OVERALL DIMENSIONS

84x42x36.5

TOP

Top Dimension

84x42x1.5in

- Solid Birch Butcher Block

BASE

Construction

- Welded Steel Tube

50mm O.D., 3mm wall

Foot

Material: Nylon

CASTERS

4 - 4" Locking Directional Total Lock

- High Strength Steel

- TPU Tread, Non-Marking

- Corrosion Resistant

- 300lb load rating (per caster)

POWER (OPTIONAL)

In Surface Power Unit

- Manufacturer : Byrne

- 3 110v Power, 2 USB

- Integrated Circuit Breaker Rating

13 amps, 125 volts

Cord (Provided)

- NEMA 5-15, 14 AWG, 3 Conductor,

15 Amp, 10 foot

SPECIFICATIONS

Max Load

- TBD

Paint

- Textured Powder coat

MODULE OPTIONS*

4 Module Configuration

- Double Module Configurations

Double storage

Double storage with locking doors

- Single Module Configurations

Single storage

Single storage with doors

Bin storage

Peg board

*Refer to module specifications for more information

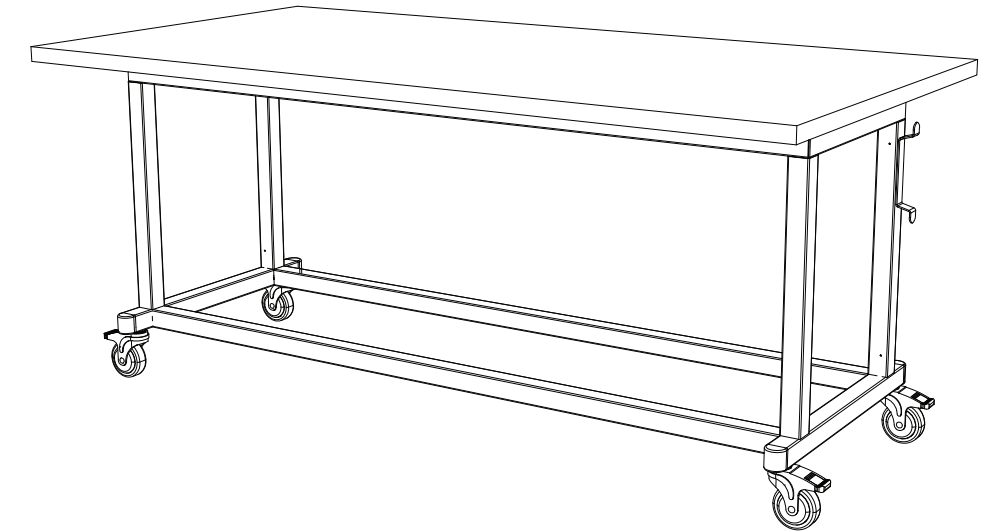

FRONT VIEW

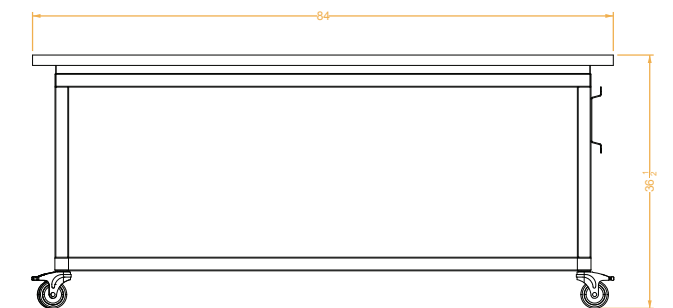

TOP VIEW



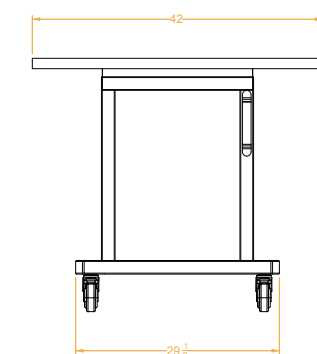

SIDE VIEW

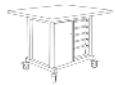
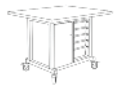

Explorer Series®

maker table configured

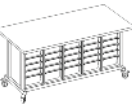
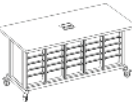
DESCRIPTION	ITEM #	D	W	H	PRICE	SHIP WT.	LEAD TIME*
Maker Table 2 Module, 42d x 48w, butcher block top, 1 bin storage module, 1 single storage with doors and locking casters. Platinum frame only.	MK1BD.4248.P2	42"	48"	36.5"	\$5666	481	S
							
Maker table, 42d x 48w, butcher block top, 1 bin storage module, 1 single storage with doors, power unit with 8ft extension cord and locking casters. Platinum frame only.	MK1EBD.4248.P2	42"	48"	36.5"	\$7020	481	S
							
Maker table, 42d x 48w, butcher block top, 3 bin storage modules and locking casters. Platinum frame only.	MK1BBB.4248.P2	42"	48"	36.5"	\$6862	481	S
							
Maker table, 42d x 84w, butcher block top, 5 bin storage modules and locking casters.	MK1BBBBN.4284	42"	84"	36.5"	\$8678	481	S
							
Maker table, 42d x 84w, butcher block top, 5 bin storage modules, power unit with 8ft extension cord and locking casters.	MK1EBBBN.4284	42"	84"	36.5"	\$10032	486	S
							

to order

1. Item Number
2. Paint Finish
See paint finish options for frame below

example **MK1BBBBN.4284 - GA**

ITEM NUMBER PAINT FINISH

please separate each item with a dash

storage modules platinum finish only

MODEL	DESCRIPTION
B = BINSM	Bin Storage Module- 14.7"W x 21.75"d x 24.5"H with clear tote bin pack Four - 4"H x 20.875"L x 12.74"W and One - 6"H x 20.875"L x 12.74"W
S = SGLSM	Single Storage Module without door- 14.7"W x 21.75"d x 24.5"H
D = SGLSMD	Single Storage Module w/ locking door - 14.7"W x 21.75"d x 24.5"H
P = PEGSM	Peg Board Module - 14.7"W x 21.75"d x 24.5"H (Doesn't include pegs or spools)
T = TOOLSM	Tool Storage Module - 14.7"W x 21.75"D x 24.5"H
S2 = DBLSM (uses 2 positions)	Double Storage Module without doors - 29.4"W x 21.75"D x 24.5"H
D2 = DBLSMD (uses 2 positions)	Double Storage Module w/ locking doors - 29.4"W x 21.75"D x 24.5"H

paint finish options for frame

MODEL	DESCRIPTION
GA	Green Apple
EN	Navy
P2	Textured Platinum

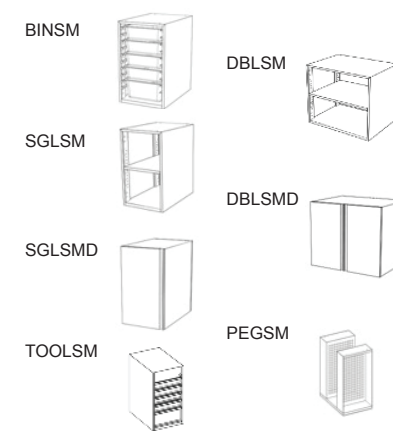

to order additional bins

MODEL	DESCRIPTION	PRICE
BINPK46	Clear Tote Bin Pack - Four - 4"H x 20.875"L x 12.74"W and One - 6"H x 20.875"L x 12.74"W	\$274
BINPK4	Clear Tote Bin - 4"H x 20.875"L x 12.74"W Pack of 6	\$308
BINPK6	Clear Tote Bin - 6"H x 20.875"L x 12.74"W Pack of 6	\$412

Note: Maker tables ship KD: Storage modules are shipped assembled except doors need to be attached onsite when applicable.
Freight Class 150 Origin zip 49548
* S - Standard Lead Time 4-6 weeks

Explorer Series®

maker table configured

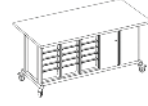
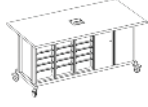
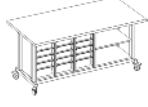
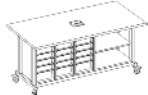
DESCRIPTION	ITEM #	D	W	H	PRICE	SHIP WT.	LEAD TIME*
Maker table, 42d x 84w, butcher block top, 3 bin storage modules, 1 double storage module with doors and locking casters.	MK1BBBD2.4284	42"	84"	36.5"	\$8144	478	S
							
Maker table, 42d x 84w, butcher block top, 3 bin storage modules, 1 double storage module with doors, power unit with 8ft extension cord and locking casters.	MK1EBBD2.4284	42"	84"	36.5"	\$9498	483	S
							
Maker table, 42d x 84w, butcher block top, 3 bin storage modules, 1 double storage module without doors and locking casters.	MK1BBBS2.4284	42"	84"	36.5"	\$7700	457	S
							
Maker table, 42d x 84w, butcher block top, 3 bin storage modules, 1 double storage module without doors, power unit with 8ft extension cord and locking casters.	MK1EBBS2.4284	42"	84"	36.5"	\$9054	462	S
							

to order

1. Item Number
2. Paint Finish
See paint finish options for frame below

example **MK1BBBBN.4284 - GA**

ITEM NUMBER PAINT FINISH

please separate each item with a dash

storage modules platinum finish only

MODEL	DESCRIPTION
B = BINSM	Bin Storage Module- 14.7"W x 21.75"d x 24.5"H with clear tote bin pack Four - 4"H x 20.875"L x 12.74"W and One - 6"H x 20.875"L x 12.74"W
S = SGLSM	Single Storage Module without door- 14.7"W x 21.75"d x 24.5"H
D = SGLSMD	Single Storage Module w/ locking door - 14.7"W x 21.75"d x 24.5"H
P = PEGSM	Peg Board Module - 14.7"W x 21.75"d x 24.5"H (Doesn't include pegs or spools)
T = TOOLSM	Tool Storage Module - 14.7"W x 21.75"D x 24.5"H
S2 = DBLSM (uses 2 positions)	Double Storage Module without doors - 29.4"W x 21.75"D x 24.5"H
D2 = DBLSMD (uses 2 positions)	Double Storage Module w/ locking doors - 29.4"W x 21.75"D x 24.5"H

paint finish options for frame

MODEL	DESCRIPTION
GA	Green Apple
EN	Navy
P2	Textured Platinum

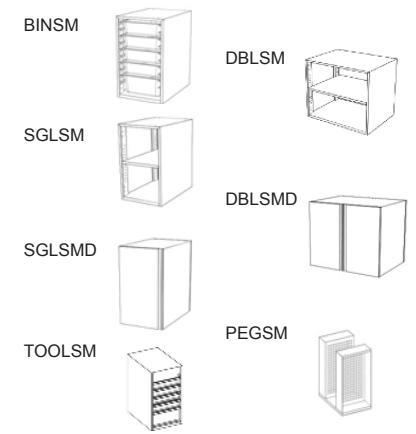

to order additional bins

MODEL	DESCRIPTION	PRICE
BINPK46	Clear Tote Bin Pack - Four - 4"H x 20.875"L x 12.74"W and One - 6"H x 20.875"L x 12.74"W	\$274
BINPK4	Clear Tote Bin - 4"H x 20.875"L x 12.74"W Pack of 6	\$308
BINPK6	Clear Tote Bin - 6"H x 20.875"L x 12.74"W Pack of 6	\$412

Note: Maker tables ship KD: Storage modules are shipped assembled except doors need to be attached onsite when applicable.
Freight Class 150 Origin zip 49548
* S - Standard Lead Time 4-6 weeks

Explorer Series®

maker table configured

DESCRIPTION	ITEM #	D	W	H	PRICE	SHIP WT.	LEAD TIME*
Maker table, 42d x 84w, butcher block top, 2 bin storage modules, 1 peg board storage module, 1 double storage module without doors and locking casters.	MK1BBPS2.4284	42"	84"	36.5"	\$7440	439	S



Maker table, 42d x 84w, butcher block top, 2 bin storage modules, 1 peg board storage module, 1 double storage module without doors, power unit with 8ft extension cord and locking casters.	MK1EBBPS2.4284	42"	84"	36.5"	\$8794	444	S
--	----------------	-----	-----	-------	--------	-----	---



Maker table, 42d x 84w, butcher block top, 1 bin storage module, 1 single storage module with door, 1 double storage module with doors, 1 bin storage module and locking casters.	MK1BDD2B.4284	42"	84"	36.5"	\$7994	491	S
---	---------------	-----	-----	-------	--------	-----	---

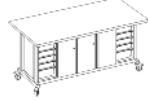

to order
1. Item Number
2. Paint Finish
See paint finish options for frame below

example **MK1BBBBN.4284 - GA**
ITEM NUMBER PAINT FINISH
please separate each item with a dash

storage modules platinum finish only

MODEL	DESCRIPTION
B = BINSM	Bin Storage Module- 14.7"W x 21.75"d x 24.5"H with clear tote bin pack Four - 4"H x 20.875"L x 12.74"W and One - 6"H x 20.875"L x 12.74"W
S = SGLSM	Single Storage Module without door- 14.7"W x 21.75"d x 24.5"H
D = SGLSMD	Single Storage Module w/ locking door - 14.7"W x 21.75"d x 24.5"H
P = PEGSM	Peg Board Module - 14.7"W x 21.75"d x 24.5"H (Doesn't include pegs or spools)
T = TOOLSM	Tool Storage Module - 14.7"W x 21.75"D x 24.5"H
S2 = DBLSM (uses 2 positions)	Double Storage Module without doors - 29.4"W x 21.75"D x 24.5"H
D2 = DBLSMD (uses 2 positions)	Double Storage Module w/ locking doors - 29.4"W x 21.75"D x 24.5"H

to order additional bins

MODEL	DESCRIPTION	PRICE
BINPK46	Clear Tote Bin Pack - Four - 4"H x 20.875"L x 12.74"W and One - 6"H x 20.875"L x 12.74"W	\$274
BINPK4	Clear Tote Bin - 4"H x 20.875"L x 12.74"W Pack of 6	\$308
BINPK6	Clear Tote Bin - 6"H x 20.875"L x 12.74"W Pack of 6	\$412

Note: Maker tables ship KD: Storage modules are shipped assembled except doors need to be attached onsite when applicable.
Freight Class 150 Origin zip 49548
* S - Standard Lead Time 4-6 weeks

paint finish options for frame

MODEL	DESCRIPTION
GA	Green Apple
EN	Navy
P2	Textured Platinum

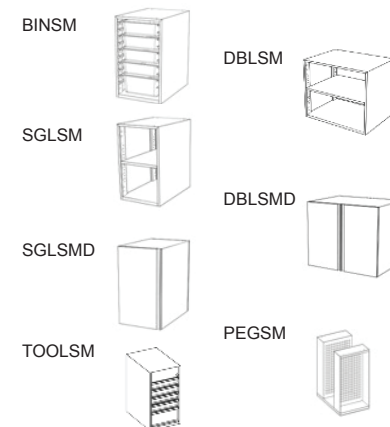

Explorer Series®

maker table configured

DESCRIPTION	ITEM #	D	W	H	PRICE	SHIP WT.	LEAD TIME*
Maker table, 42d x 84w, butcher block top, 1 bin storage module, 1 single storage module with door, 1 double storage module with doors, 1 bin storage module, power unit with 8ft extension cord and locking casters.	MK1EBDD2B.4284	42"	84"	36.5"	\$9348	496	S

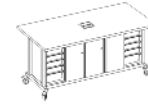

Maker table, 42d x 84w, butcher block top, 1 double storage module without doors, 1 bin storage module, 1 double storage module without doors and locking casters.	MK1S2BS2.4284	42"	84"	36.5"	\$6722	409	S
--	---------------	-----	-----	-------	--------	-----	---



Maker table, 42d x 84w, butcher block top, 1 double storage module without doors, 1 bin storage module, 1 double storage module without doors, power unit with 8ft extension cord and locking casters.	MK1ES2BS2.4284	42"	84"	36.5"	\$8076	414	S
--	----------------	-----	-----	-------	--------	-----	---

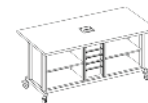

to order
1. Item Number
2. Paint Finish
See paint finish options for frame below

example **MK1BBBBN.4284 - GA**
ITEM NUMBER PAINT FINISH
please separate each item with a dash

storage modules platinum finish only

MODEL	DESCRIPTION
B = BINSM	Bin Storage Module- 14.7"W x 21.75"d x 24.5"H with clear tote bin pack Four - 4"H x 20.875"L x 12.74"W and One - 6"H x 20.875"L x 12.74"W
S = SGLSM	Single Storage Module without door- 14.7"W x 21.75"d x 24.5"H
D = SGLSMD	Single Storage Module w/ locking door - 14.7"W x 21.75"d x 24.5"H
P = PEGSM	Peg Board Module - 14.7"W x 21.75"d x 24.5"H (Doesn't include pegs or spools)
T = TOOLSM	Tool Storage Module - 14.7"W x 21.75"D x 24.5"H
S2 = DBLSM (uses 2 positions)	Double Storage Module without doors - 29.4"W x 21.75"D x 24.5"H
D2 = DBLSMD (uses 2 positions)	Double Storage Module w/ locking doors - 29.4"W x 21.75"D x 24.5"H

to order additional bins

MODEL	DESCRIPTION	PRICE
BINPK46	Clear Tote Bin Pack - Four - 4"H x 20.875"L x 12.74"W and One - 6"H x 20.875"L x 12.74"W	\$274
BINPK4	Clear Tote Bin - 4"H x 20.875"L x 12.74"W Pack of 6	\$308
BINPK6	Clear Tote Bin - 6"H x 20.875"L x 12.74"W Pack of 6	\$412

Note: Maker tables ship KD: Storage modules are shipped assembled except doors need to be attached onsite when applicable.
Freight Class 150 Origin zip 49548
* S - Standard Lead Time 4-6 weeks

paint finish options for frame

MODEL	DESCRIPTION
GA	Green Apple
EN	Navy
P2	Textured Platinum

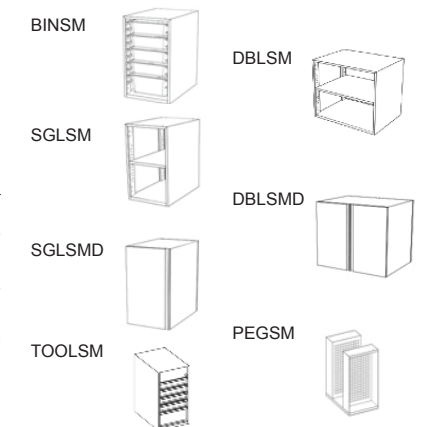

Explorer Series®

maker table configured

DESCRIPTION	ITEM #	D	W	H	PRICE	SHIP WT.	LEAD TIME*
Maker table, 42d x 84w, butcher block top, 1 double storage module with doors, 1 bin storage module, 1 double storage module with doors and locking casters.	MK1D2BD2.4284	42"	84"	36.5"	\$7610	475	S

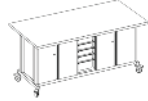

Maker table, 42d x 84w, butcher block top, 1 double storage module with doors, 1 bin storage module, 1 double storage module with doors, power unit with 8ft extension cord and locking casters.	MK1ED2BD2.4284	42"	84"	36.5"	\$8964	480	S
--	----------------	-----	-----	-------	--------	-----	---

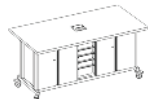

Maker table, 42d x 84w, butcher block top, 1 double storage module with doors, 1 bin storage module, 1 double storage module without doors and locking casters.	MK1D2BS2.4284	42"	84"	36.5"	\$7166	453	S
---	---------------	-----	-----	-------	--------	-----	---

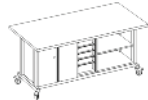

to order
1. Item Number
2. Paint Finish
See paint finish options for frame below

example **MK1BBBBN.4284 - GA**
ITEM NUMBER PAINT FINISH
please separate each item with a dash

storage modules platinum finish only

MODEL	DESCRIPTION
B = BINSM	Bin Storage Module- 14.7"W x 21.75"D x 24.5"H with clear tote bin pack Four - 4"H x 20.875"L x 12.74"W and One - 6"H x 20.875"L x 12.74"W
S = SGLSM	Single Storage Module without door- 14.7"W x 21.75"D x 24.5"H
D = SGLSMD	Single Storage Module w/ locking door - 14.7"W x 21.75"D x 24.5"H
P = PEGSM	Peg Board Module - 14.7"W x 21.75"D x 24.5"H (Doesn't include pegs or spools)
T = TOOLSM	Tool Storage Module - 14.7"W x 21.75"D x 24.5"H
S2 = DBLSM (uses 2 positions)	Double Storage Module without doors - 29.4"W x 21.75"D x 24.5"H
D2 = DBLSMD (uses 2 positions)	Double Storage Module w/ locking doors - 29.4"W x 21.75"D x 24.5"H

to order additional bins

MODEL	DESCRIPTION	PRICE
BINPK46	Clear Tote Bin Pack - Four - 4"H x 20.875"L x 12.74"W and One - 6"H x 20.875"L x 12.74"W	\$274
BINPK4	Clear Tote Bin - 4"H x 20.875"L x 12.74"W Pack of 6	\$308
BINPK6	Clear Tote Bin - 6"H x 20.875"L x 12.74"W Pack of 6	\$412

Note: Maker tables ship KD: Storage modules are shipped assembled except doors need to be attached onsite when applicable.

Freight Class 150 Origin zip 49548

* S - Standard Lead Time 4-6 weeks

paint finish options for frame

MODEL	DESCRIPTION
GA	Green Apple
EN	Navy
P2	Textured Platinum

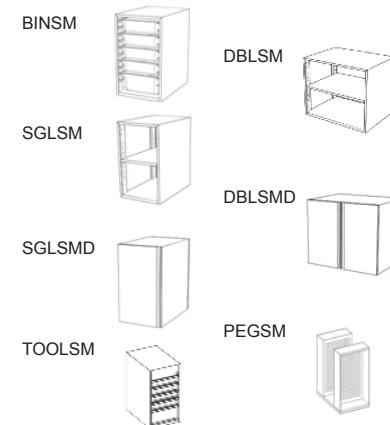

Explorer Series®

maker table configured

DESCRIPTION	ITEM #	D	W	H	PRICE	SHIP WT.	LEAD TIME*
Maker table, 42d x 84w, butcher block top, 1 double storage module with doors, 1 bin storage module, 1 double storage module without doors, power unit with 8ft extension cord and locking casters.	MK1ED2BS2.4284	42"	84"	36.5"	\$8520	458	S

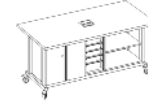

Maker table, 42d x 84w, butcher block top, 1 double storage module with doors, 1 peg board storage module, 1 double storage module without doors and locking casters.	MK1D2PS2.4284	42"	84"	36.5"	\$6906	454	S
---	---------------	-----	-----	-------	--------	-----	---

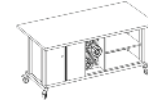

Maker table, 42d x 84w, butcher block top, 1 double storage module with doors, 1 peg board storage module, 1 double storage module without doors, power unit with 8ft extension cord and locking casters.	MK1ED2PS2.4284	42"	84"	36.5"	\$8260	459	S
---	----------------	-----	-----	-------	--------	-----	---

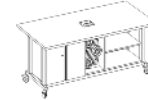

to order
1. Item Number
2. Paint Finish
See paint finish options for frame below

example **MK1BBBBN.4284 - GA**
ITEM NUMBER PAINT FINISH
please separate each item with a dash

storage modules platinum finish only

MODEL	DESCRIPTION
B = BINSM	Bin Storage Module- 14.7"W x 21.75"D x 24.5"H with clear tote bin pack Four - 4"H x 20.875"L x 12.74"W and One - 6"H x 20.875"L x 12.74"W
S = SGLSM	Single Storage Module without door- 14.7"W x 21.75"D x 24.5"H
D = SGLSMD	Single Storage Module w/ locking door - 14.7"W x 21.75"D x 24.5"H
P = PEGSM	Peg Board Module - 14.7"W x 21.75"D x 24.5"H (Doesn't include pegs or spools)
T = TOOLSM	Tool Storage Module - 14.7"W x 21.75"D x 24.5"H
S2 = DBLSM (uses 2 positions)	Double Storage Module without doors - 29.4"W x 21.75"D x 24.5"H
D2 = DBLSMD (uses 2 positions)	Double Storage Module w/ locking doors - 29.4"W x 21.75"D x 24.5"H

to order additional bins

MODEL	DESCRIPTION	PRICE
BINPK46	Clear Tote Bin Pack - Four - 4"H x 20.875"L x 12.74"W and One - 6"H x 20.875"L x 12.74"W	\$274
BINPK4	Clear Tote Bin - 4"H x 20.875"L x 12.74"W Pack of 6	\$308
BINPK6	Clear Tote Bin - 6"H x 20.875"L x 12.74"W Pack of 6	\$412

Note: Maker tables ship KD: Storage modules are shipped assembled except doors need to be attached onsite when applicable.

Freight Class 150 Origin zip 49548

* S - Standard Lead Time 4-6 weeks

paint finish options for frame

MODEL	DESCRIPTION
GA	Green Apple
EN	Navy
P2	Textured Platinum

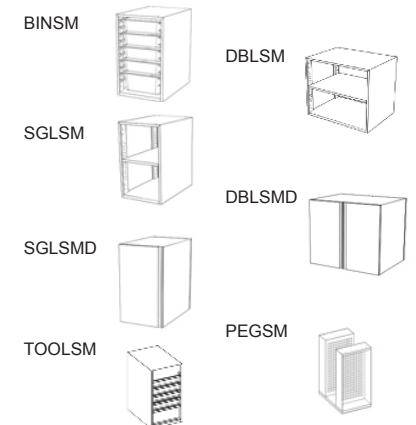

Explorer Series®

maker table configured

DESCRIPTION	ITEM #	D	W	H	PRICE	SHIP WT.	LEAD TIME*
Maker table, 42d x 84w, butcher block top, 1 double storage module with doors, 1 single storage module with doors, 1 double storage module with doors and locking casters.	MK1D2DD2.4284	42"	84"	36.5"	\$7460	487	S
Maker table, 42d x 84w, butcher block top, 1 double storage module with doors, 1 single storage module with doors, 1 double storage module with doors, power unit with 8ft extension cord and locking casters.	MK1ED2DD2.4284	42"	84"	36.5"	\$8814	492	S
Maker table, 42d x 84w, butcher block top, 1 double storage module without doors, 1 single storage module without doors, 1 double storage module without doors and locking casters.	MK1S2SS2.4284	42"	84"	36.5"	\$6368	434	S
Maker table, 42d x 84w, butcher block top, 1 double storage module without doors, 1 single storage module without doors, 1 double storage module without doors, power unit with 8ft extension cord and locking casters.	MK1ES2SS2.4284	42"	84"	36.5"	\$7722	439	S

to order	example
1. Item Number 2. Paint Finish <i>See paint finish options for frame below</i>	MK1BBBBN.4284 - GA ITEM NUMBER PAINT FINISH <i>please separate each item with a dash</i>

storage modules platinum finish only

MODEL	DESCRIPTION
B = BINSM	Bin Storage Module- 14.7"W x 21.75"d x 24.5"H with clear tote bin pack Four - 4"H x 20.875"L x 12.74"W and One - 6"H x 20.875"L x 12.74"W
S = SGLSM	Single Storage Module without door- 14.7"W x 21.75"d x 24.5"H
D = SGLSMD	Single Storage Module w/ locking door - 14.7"W x 21.75"d x 24.5"H
P = PEGSM	Peg Board Module - 14.7"W x 21.75"d x 24.5"H (Doesn't include pegs or spools)
T = TOOLSM	Tool Storage Module - 14.7"W x 21.75"D x 24.5"H
S2 = DBLSM (uses 2 positions)	Double Storage Module without doors - 29.4"W x 21.75"D x 24.5"H
D2 = DBLSMD (uses 2 positions)	Double Storage Module w/ locking doors - 29.4"W x 21.75"D x 24.5"H

to order additional bins

MODEL	DESCRIPTION	PRICE
BINPK46	Clear Tote Bin Pack - Four - 4"H x 20.875"L x 12.74"W and One - 6"H x 20.875"L x 12.74"W	\$274
BINPK4	Clear Tote Bin - 4"H x 20.875"L x 12.74"W Pack of 6	\$308
BINPK6	Clear Tote Bin - 6"H x 20.875"L x 12.74"W Pack of 6	\$412

Note: Maker tables ship KD: Storage modules are shipped assembled except doors need to be attached onsite when applicable.
Freight Class 150 Origin zip 49548
* S - Standard Lead Time 4-6 weeks

paint finish options for frame

MODEL	DESCRIPTION
GA	Green Apple
EN	Navy
P2	Textured Platinum

MODEL	DESCRIPTION
BINSM	
DBLSM	
SGLSM	
DBLSMD	
SGLSMD	
TOOLSM	
PEGSM	

Explorer Series®

maker table - build your own

DESCRIPTION	ITEM #	D	W	H	PRICE	SHIP WT.	LEAD TIME*
Maker Table 2 Module, 42d x 48w, butcher block top and locking casters. Add up to 2 storage modules, sold separately. Platinum frame only.	MK1xx.4248	42"	84"	36.5"	\$4000	296	S
Maker Table 2 Module, 42d x 48w, butcher block top, power unit with 8ft extension cord and locking casters and locking casters. Add up to 2 storage modules, sold separately. Platinum frame only	MK1Exx.4248	42"	84"	36.5"	\$5354	296	S

to order	example
How to Build Your Own item number Replace "x" with storage module item number listed below. Leave "x" for empty modules (positions are laid out left to right)	MK1 or MK1E 1. Position 1 2. Position 2 3. Position 3 4. Position 4 5. Position 5
	(bin storage module, single storage module without doors, ped board module, double storage module with locking doors)
	B S P D 2 P1 P2 P3 P4 P5
	Configurations: Five 14.7"W Modules Two 29.4"W Modules + One 14.7"W Module One 29.4"W Module + Three 14.7"W Modules 29.4"W Modules use 2 positions
1. Item Number 2. Paint Finish <i>See paint finish options for frame below</i>	MK1BSPD2.4284 - GA ITEM NUMBER PAINT FINISH <i>please separate each item with a dash</i>

storage modules platinum finish only

MODEL	DESCRIPTION	PRICE	SHIP WT
B = BINSM	Bin Storage Module- 14.7"W x 21.75"d x 24.5"H with clear tote bin pack Four - 4"H x 20.875"L x 12.74"W and One - 6"H x 20.875"L x 12.74"W	\$908	37
S = SGLSM	Single Storage Module without door- 14.7"W x 21.75"d x 24.5"H	\$554	38
D = SGLSMD	Single Storage Module w/ locking door - 14.7"W x 21.75"d x 24.5"H	\$758	49
P = PEGSM	Peg Board Module - 14.7"W x 21.75"d x 24.5"H (Doesn't include pegs or spools)	\$648	31
T = TOOLSM	Tool Storage Module - 14.7"W x 21.75"D x 24.5"H	\$1098	
S2 = DBLSM (uses 2 positions)	Double Storage Module without doors - 29.4"W x 21.75"D x 24.5"H	\$838	50
D2 = DBLSMD (uses 2 positions)	Double Storage Module w/ locking doors - 29.4"W x 21.75"D x 24.5"H	\$1282	71

to order additional bins

MODEL	DESCRIPTION	PRICE
BINPK46	Clear Tote Bin Pack - Four - 4"H x 20.875"L x 12.74"W and One - 6"H x 20.875"L x 12.74"W	\$274
BINPK4	Clear Tote Bin - 4"H x 20.875"L x 12.74"W Pack of 6	\$308
BINPK6	Clear Tote Bin - 6"H x 20.875"L x 12.74"W Pack of 6	\$412

paint finish options for frame

MODEL	DESCRIPTION
GA	Green Apple
EN	Navy
P2	Textured Platinum

Note: Maker tables ship KD: Storage modules are shipped assembled except doors need to be attached onsite when applicable.
Freight Class 150 Origin zip 49548
* S - Standard Lead Time 4-6 weeks

Explorer Series®

maker table - build your own

DESCRIPTION	ITEM #	D	W	H	PRICE	SHIP WT.	LEAD TIME*
Maker table, 42d x 84w, butcher block top and locking casters. Add up to 5 storage modules, sold separately.	MK1xxxxx.4284	42"	84"	36.5"	\$4138	296	S



Maker table, 42d x 84w, butcher block top, power unit with 8ft extension cord and locking casters. Add up to 5 storage modules, sold separately.	MK1Exxxxx.4284	42"	84"	36.5"	\$5492	296	S
--	----------------	-----	-----	-------	--------	-----	---



to order How to Build Your Own item number

Replace "x" with storage module item number listed below.
Leave "x" for empty modules (positions are laid out left to right)

example (bin storage module, single storage module without doors, peg board module, double storage module with locking doors)

MK1 or MK1E

- Position 1
- Position 2
- Position 3
- Position 4
- Position 5

B S P D 2

P1 P2 P3 P4 P5

Configurations: Five 14.7"W Modules
Two 29.4"W Modules + One 14.7"W Module
One 29.4"W Module + Three 14.7"W Modules
29.4"W Modules use 2 positions

to order

- Item Number
- Paint Finish

See paint finish options for frame below

example **MK1BSPD2.4284 - GA**

ITEM NUMBER PAINT FINISH

please separate each item with a dash

storage modules platinum finish only

MODEL	DESCRIPTION	PRICE	SHIP WT.
B = BINSM	Bin Storage Module- 14.7"W x 21.75"D x 24.5"H with clear tote bin pack Four - 4"H x 20.875"L x 12.74"W and One - 6"H x 20.875"L x 12.74"W	\$908	37
S = SGLSM	Single Storage Module without door- 14.7"W x 21.75"D x 24.5"H	\$554	38
D = SGLSMD	Single Storage Module w/ locking door - 14.7"W x 21.75"D x 24.5"H	\$758	49
P = PEGSM	Peg Board Module - 14.7"W x 21.75"D x 24.5"H (Doesn't include pegs or spools)	\$648	31
T = TOOLSM	Tool Storage Module - 14.7"W x 21.75"D x 24.5"H	\$1098	
S2 = DBLSM (uses 2 positions)	Double Storage Module without doors - 29.4"W x 21.75"D x 24.5"H	\$838	50
D2 = DBLSMD (uses 2 positions)	Double Storage Module w/ locking doors - 29.4"W x 21.75"D x 24.5"H	\$1282	71

to order additional bins

MODEL	DESCRIPTION	PRICE	BINSM	DBLSM	SGLSM	DBLSMD	SGLSMD	PEGSM	TOOLSM
BINPK46	Clear Tote Bin Pack - Four - 4"H x 20.875"L x 12.74"W and One - 6"H x 20.875"L x 12.74"W	\$274							
BINPK4	Clear Tote Bin - 4"H x 20.875"L x 12.74"W Pack of 6	\$308							
BINPK6	Clear Tote Bin - 6"H x 20.875"L x 12.74"W Pack of 6	\$412							

paint finish options for frame

MODEL	DESCRIPTION
GA	Green Apple
EN	Navy
P2	Textured Platinum

Note: Maker tables ship KD: Storage modules are shipped assembled except doors need to be attached onsite when applicable.

Freight Class 150 Origin zip 49548

* S - Standard Lead Time 4-6 weeks

Explorer Series®

introduction - carts

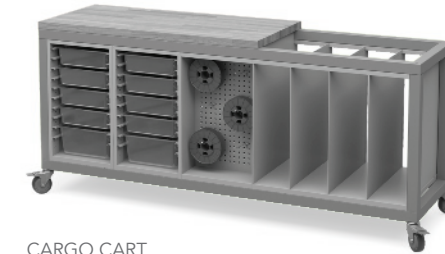

CARGO CART



CUBBY STORAGE CART



TALL STORAGE CART



PACK CART



MARKER BOARD BACK

General

The makerspace movement is becoming a powerful part of many school district curriculums. Schools are repurposing classrooms, renovating computer labs, and retooling media centers to accommodate the tools required for these creative spaces. To help foster and grow these new creative spaces, Haskell created The Rover® Table and Explorer Series®. It is a collection of innovative makerspace solutions to help schools create engaging and functional spaces while catering to the needs of these unique creative areas.

Engineered to be easily transported across the hall or across the district, the Rover® Table is the ideal solution for a shared maker curriculum.

The Explorer Series® Think Nook™ is the perfect solution for students who need quiet time to think, read or simply recharge.

The Explorer Maker Table by Haskell has been designed to meet the demanding needs of these creative environments.

The Explorer Cargo Cart by Haskell is the perfect support solution to our Rover® Table and Maker Table allowing easy access to all the many different maker manipulatives needed.

The Tall Storage Cart allows educators to organize, store and distribute learning materials or maker manipulatives.

The Cubby Storage Cart is a versatile, mobile piece that offers a sleek design solution for classroom storage and makerspaces.

The Pack Cart replaces the need for built in casework or lockers by providing mobile backpack storage while functioning as a multipurpose ideation tool.

Explorer Series®

cargo cart configuration

Cargo Cart Module Configuration

The Cargo Cart can be configured to fit the needs of your classroom or makerspace. Seven different modules are available and include open and secured storage modules, peg boards for hanging supplies like 3d printing filament, and a large format storage module which is unique to the cargo cart. A large number of pre-configured Cargo Carts are provided on the next few pages. You can also create your own custom configuration using the information below when ordering.

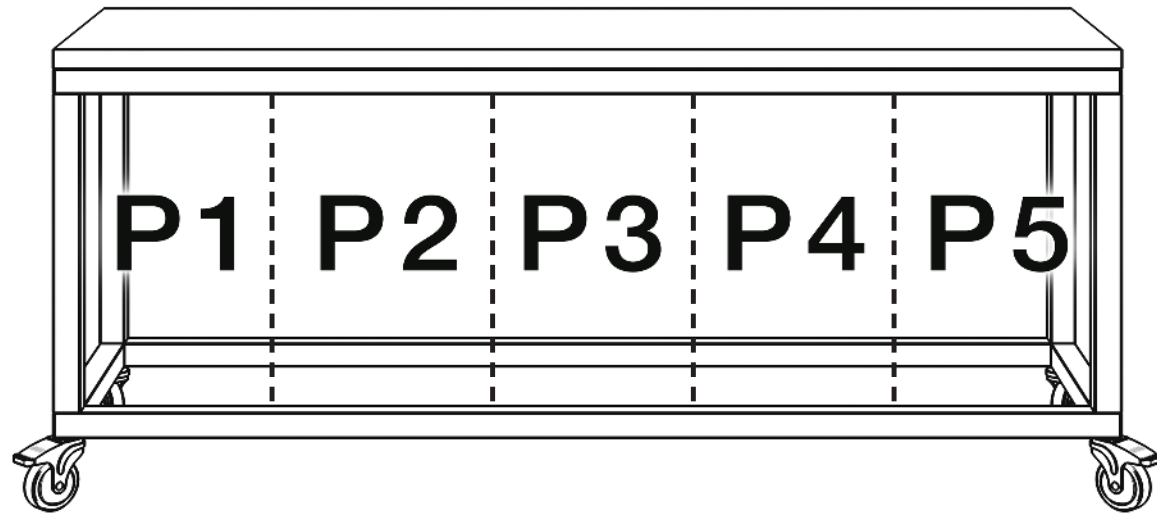

One Position Storage Modules

These storage modules use one position in the Cargo Cart.

Bin Storage Module
BINSM

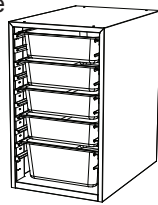

Single Storage Module*
SGLSM

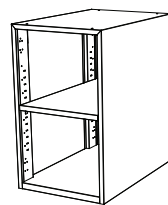

Single Storage Module with Locking Door*
SGLSMD

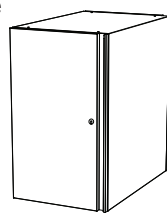

Tool Storage Module*
TOOLSM

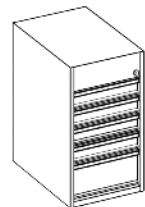

Peg Board Module
PEGSM

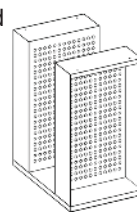

Two Position Storage Modules

These storage modules use two positions side-by-side.

Double Storage Module
DBLSM

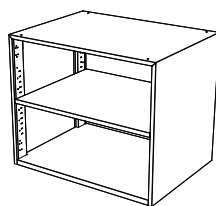

Double Storage Module with Locking Doors
DBLSMD

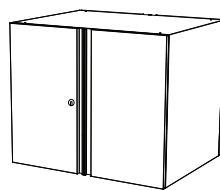

Large Format Storage Module
LGFTSM

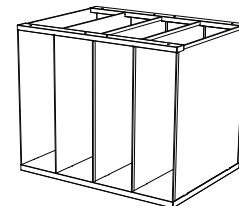

This module can only be used with the Cargo Cart CG1 Partial Top Model to allow for full access to the Large Format Storage Module

Get Started with a Pre-Configured Cargo Cart, or Configure Your Own!

*When specifying the single storage module or the tool storage module, you cannot specify five of these modules in a row within the frame of the Cargo Cart.

Explorer Series®

cargo cart specification

OVERALL DIMENSIONS

77.5x22x35.5

TOP

Top Dimension

Partial Top: 47x22x1.5

Full Top: 77.5x22x1.5

- Solid Birch Butcher Block

BASE

Construction

- Welded Steel Tube

50mm O.D., 3mm wall

- 18 Gauge Formed and Welded Steel

Foot

Material: Nylon

CASTERS

4 - 4" Locking Directional Total Lock

- High Strength Steel

- TPU Tread, Non-Marking

- Corrosion Resistant

- 300lb load rating (per caster)

SPECIFICATIONS

Max Load

- TBD

Paint

- Textured Powder coat

MODULE OPTIONS*

4 Module Configuration

- Double Module Configurations

Double storage

Double storage with locking door

Large Format Storage

- Single Module Configurations

Single storage

Single storage with doors

Bin storage

Peg board

*Refer to module specifications for more information

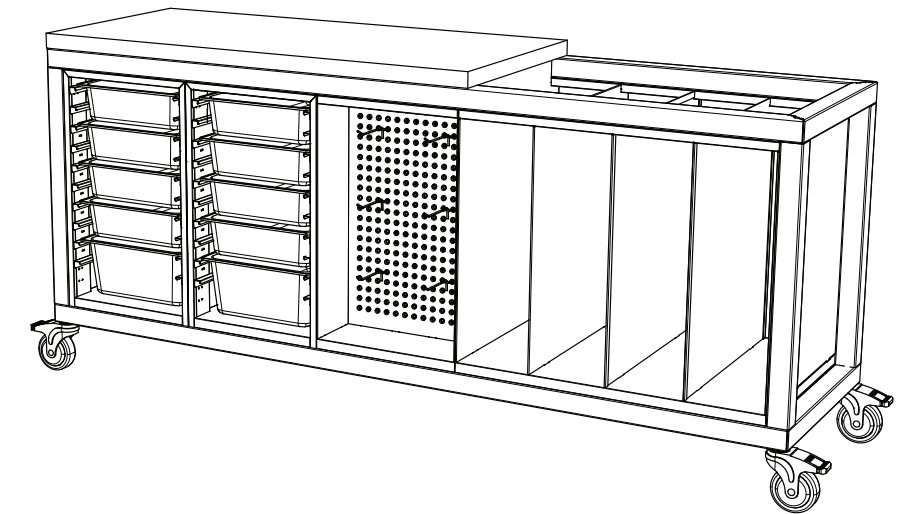

FRONT VIEW - PARTIAL TOP

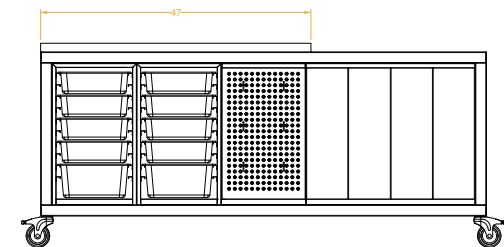

FRONT VIEW - FULL TOP

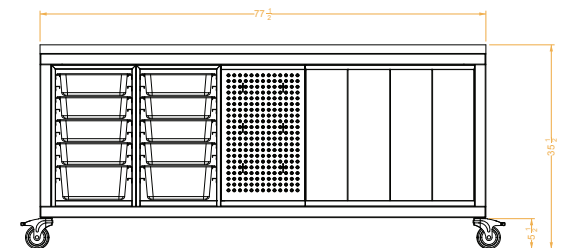

TOP VIEW - PARTIAL TOP

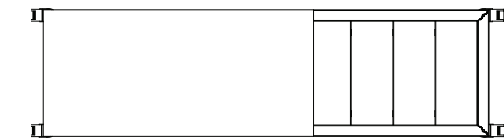

TOP VIEW - FULL TOP

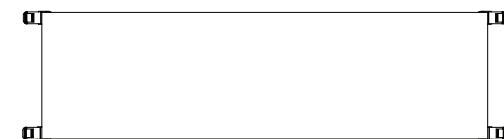

SIDE VIEW

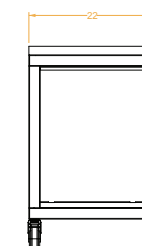

Explorer Series®

cargo cart configured

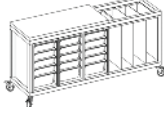
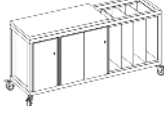
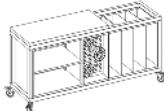
DESCRIPTION	ITEM #	D	W	H	PRICE	SHIP WT.	LEAD TIME*
Cargo Cart with 22d x 46w butcher block top, 3 bin storage modules, 1 large format storage module and locking casters.	CG1BBBL2.2246	22"	77.5"	35.5"	\$6310	373	S
							
Cargo Cart with 22d x 46w butcher block top, 1 double storage module with doors, 1 single storage module with door, 1 large format storage module and locking casters.	CG1D2DL2.2246	22"	77.5"	35.5"	\$5626	382	S
							
Cargo Cart with 22d x 46w butcher block top, 1 double storage module without doors, 1 peg board storage module, 1 large format storage module and locking casters.	CG1S2PL2.2246	22"	77.5"	35.5"	\$5072	342	*
							

to order	1. Item Number	example	CG1BBBL2.2246	-	GA
	2. Paint Finish		ITEM NUMBER	PAINT FINISH	
	<i>See paint finish options for frame below</i>		<i>please separate each item with a dash</i>		

storage modules platinum finish only

MODEL	DESCRIPTION
B = BINSM	Bin Storage Module - 14.7"W x 21.75"D x 24.5"H with bins Four - 4"H x 20.875"L x 12.74"W and One - 6"H x 20.875"L x 12.74"W
S = SGLSM	Single Storage Module - 14.7"W x 21.75"D x 24.5"H
D = SGLSMD	Single Storage Module w/ locking doors - 14.7"W x 21.75"D x 24.5"H
P = PEGSM	Peg Board Module - 14.7"W x 21.75"D x 24.5"H
T = TOOLSM	Tool Storage Module - 14.7"W x 21.75"D x 24.5"H
S2 = DBLSM (uses 2 positions)	Double Storage Module without doors - 29.4"W x 21.75"D x 24.5"H
D2 = DBLSMD (uses 2 positions)	Double Storage Module w/ locking doors - 29.4"W x 21.75"D x 24.5"H
L2 = LGFTSM (uses 2 positions)	Large Format Storage Module - 29.4"W x 21.75"D x 24.5"H Large Format Storage Module can only be used with CG2 partial top model.

paint finish options for frame

MODEL	DESCRIPTION
GA	Green Apple
EN	Navy
P2	Textured Platinum

to order additional bins

MODEL	DESCRIPTION	PRICE
BINPK46	Clear Tote Bin Pack - Four - 4"H x 20.875"L x 12.74"W and One - 6"H x 20.875"L x 12.74"W	\$274
BINPK4	Clear Tote Bin - 4"H x 20.875"L x 12.74"W Pack of 6	\$308
BINPK6	Clear Tote Bin - 6"H x 20.875"L x 12.74"W Pack of 6	\$412

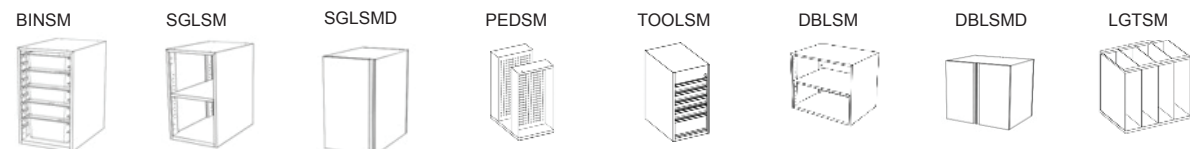

Note: Cargo carts ship KD: Storage modules are shipped assembled except doors need to be attached onsite when applicable.
Freight Class 150 Origin zip 49548
* S - Standard Lead Time 4-6 weeks

[Return to Table of Contents](#)

Explorer Series®

cargo cart configured

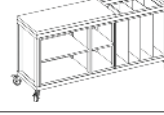
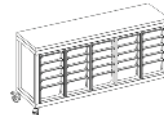
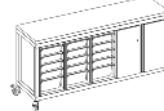
DESCRIPTION	ITEM #	D	W	H	PRICE	SHIP WT.	LEAD TIME*
Cargo Cart with 22d x 46w butcher block top, 1 double storage module without doors, 1 single storage unit without door, 1 large format storage module and locking casters.	CG1S2SL2.2246	22"	77.5"	35.5"	\$4978	350	*
							
Cargo Cart with 22d x 77w butcher block top, 5 bin storage modules and locking casters.	CG2BBBN.2277	22"	77.5"	35.5"	\$7528	415	*
							
Cargo Cart with 22d x 77w butcher block top, 3 bin storage modules, 1 double storage module with doors and locking casters.	CG2BBBD2.2277	22"	77.5"	35.5"	\$6994	412	*
							

to order	1. Item Number	example	CG1BBBL2.2246	-	GA
	2. Paint Finish		ITEM NUMBER	PAINT FINISH	
	<i>See paint finish options for frame below</i>		<i>please separate each item with a dash</i>		

storage modules platinum finish only

MODEL	DESCRIPTION
B = BINSM	Bin Storage Module - 14.7"W x 21.75"D x 24.5"H with bins Four - 4"H x 20.875"L x 12.74"W and One - 6"H x 20.875"L x 12.74"W
S = SGLSM	Single Storage Module - 14.7"W x 21.75"D x 24.5"H
D = SGLSMD	Single Storage Module w/ locking doors - 14.7"W x 21.75"D x 24.5"H
P = PEGSM	Peg Board Module - 14.7"W x 21.75"D x 24.5"H
T = TOOLSM	Tool Storage Module - 14.7"W x 21.75"D x 24.5"H
S2 = DBLSM (uses 2 positions)	Double Storage Module without doors - 29.4"W x 21.75"D x 24.5"H
D2 = DBLSMD (uses 2 positions)	Double Storage Module w/ locking doors - 29.4"W x 21.75"D x 24.5"H
L2 = LGFTSM (uses 2 positions)	Large Format Storage Module - 29.4"W x 21.75"D x 24.5"H Large Format Storage Module can only be used with CG2 partial top model.

paint finish options for frame

MODEL	DESCRIPTION
GA	Green Apple
EN	Navy
P2	Textured Platinum

to order additional bins

MODEL	DESCRIPTION	PRICE
BINPK46	Clear Tote Bin Pack - Four - 4"H x 20.875"L x 12.74"W and One - 6"H x 20.875"L x 12.74"W	\$274
BINPK4	Clear Tote Bin - 4"H x 20.875"L x 12.74"W Pack of 6	\$308
BINPK6	Clear Tote Bin - 6"H x 20.875"L x 12.74"W Pack of 6	\$412

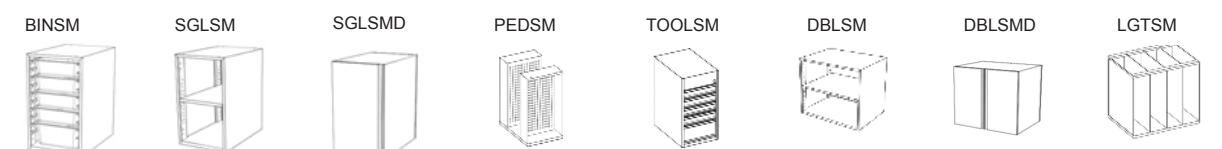

Note: Cargo carts ship KD: Storage modules are shipped assembled except doors need to be attached onsite when applicable.
Freight Class 150 Origin zip 49548
* S - Standard Lead Time 4-6 weeks

[Return to Table of Contents](#)

Explorer Series®

cargo cart configured

DESCRIPTION	ITEM #	D	W	H	PRICE	SHIP WT.	LEAD TIME*
Cargo Cart with 22d x 77w butcher block top, 3 bin storage modules, 1 double storage module without doors and locking casters.	CG2BBBS2.2277	22"	77.5"	35.5"	\$6550	391	*

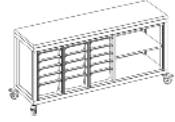

Cargo Cart with 22d x 77w butcher block top, 2 bin storage modules, 1 peg board storage module, 1 double storage module with doors and locking casters.	CG2BBPD2.2277	22"	77.5"	35.5"	\$6734	406	*
---	---------------	-----	-------	-------	--------	-----	---

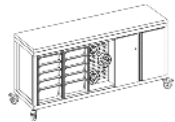

Cargo Cart with 22d x 77w butcher block top, 1 double storage module with doors, 1 peg board storage module, 2 bin storage modules and locking casters.	CG2D2PBB.2277	22"	77.5"	35.5"	\$6734	406	*
---	---------------	-----	-------	-------	--------	-----	---

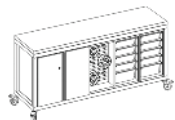

to order
1. Item Number
2. Paint Finish
See paint finish options for frame below

example
CG2BBBL2.2246 - GA
ITEM NUMBER PAINT FINISH
please separate each item with a dash

storage modules platinum finish only

MODEL	DESCRIPTION
B = BINSM	Bin Storage Module- 14.7"W x 21.75"D x 24.5"H with bins Four - 4"H x 20.875"L x 12.74"W and One - 6"H x 20.875"L x 12.74"W
S = SGLSM	Single Storage Module - 14.7"W x 21.75"D x 24.5"H
D = SGLSMD	Single Storage Module w/ locking doors - 14.7"W x 21.75"D x 24.5"H
P = PEGSM	Peg Board Module - 14.7"W x 21.75"D x 24.5"H
T = TOOLSM	Tool Storage Module - 14.7"W x 21.75"D x 24.5"H
S2 = DBLSM (uses 2 positions)	Double Storage Module without doors - 29.4"W x 21.75"D x 24.5"H
D2 = DBLSMD (uses 2 positions)	Double Storage Module w/ locking doors - 29.4"W x 21.75"D x 24.5"H
L2 = LGFTSM (uses 2 positions)	Large Format Storage Module - 29.4"W x 21.75"D x 24.5"H Large Format Storage Module can only be used with CG2 partial top model.

to order additional bins

MODEL	DESCRIPTION	PRICE
BINPK46	Clear Tote Bin Pack - Four - 4"H x 20.875"L x 12.74"W and One - 6"H x 20.875"L x 12.74"W	\$274
BINPK4	Clear Tote Bin - 4"H x 20.875"L x 12.74"W Pack of 6	\$308
BINPK6	Clear Tote Bin - 6"H x 20.875"L x 12.74"W Pack of 6	\$412

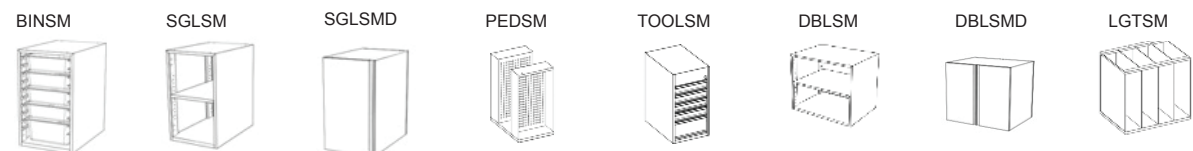

paint finish options for frame

MODEL	DESCRIPTION
GA	Green Apple
EN	Navy
P2	Textured Platinum

Note: Cargo carts ship KD: Storage modules are shipped assembled except doors need to be attached onsite when applicable.
Freight Class 150 Origin zip 49548
* S - Standard Lead Time 4-6 weeks

Explorer Series®

cargo cart configured

DESCRIPTION	ITEM #	D	W	H	PRICE	SHIP WT.	LEAD TIME*
Cargo Cart with 22d x 77w butcher block top, 1 double storage module with doors, 1 bin storage module, 1 double storage module with doors and locking casters.	CG2D2BD2.2277	22"	77.5"	35.5"	\$6460	409	*

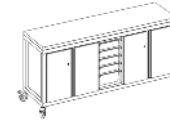

Cargo Cart with 22d x 77w butcher block top, 1 double storage module without doors, 1 bin storage module, 1 double storage module without doors and locking casters.	CG2S2BS2.2277	22"	77.5"	35.5"	\$5572	367	*
--	---------------	-----	-------	-------	--------	-----	---

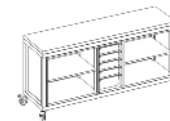

Cargo Cart with 22d x 77w butcher block top, 1 double storage module with doors, 2 peg board storage module, 1 bin storage module and locking casters.	CG2D2PPB.2277	22"	77.5"	35.5"	\$6474	400	*
--	---------------	-----	-------	-------	--------	-----	---

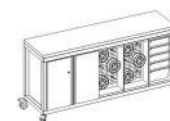

to order
1. Item Number
2. Paint Finish
See paint finish options for frame below

example
CG2BBBL2.2246 - GA
ITEM NUMBER PAINT FINISH
please separate each item with a dash

storage modules platinum finish only

MODEL	DESCRIPTION
B = BINSM	Bin Storage Module- 14.7"W x 21.75"D x 24.5"H with bins Four - 4"H x 20.875"L x 12.74"W and One - 6"H x 20.875"L x 12.74"W
S = SGLSM	Single Storage Module - 14.7"W x 21.75"D x 24.5"H
D = SGLSMD	Single Storage Module w/ locking doors - 14.7"W x 21.75"D x 24.5"H
P = PEGSM	Peg Board Module - 14.7"W x 21.75"D x 24.5"H
T = TOOLSM	Tool Storage Module - 14.7"W x 21.75"D x 24.5"H
S2 = DBLSM (uses 2 positions)	Double Storage Module without doors - 29.4"W x 21.75"D x 24.5"H
D2 = DBLSMD (uses 2 positions)	Double Storage Module w/ locking doors - 29.4"W x 21.75"D x 24.5"H
L2 = LGFTSM (uses 2 positions)	Large Format Storage Module - 29.4"W x 21.75"D x 24.5"H Large Format Storage Module can only be used with CG2 partial top model.

to order additional bins

MODEL	DESCRIPTION	PRICE
BINPK46	Clear Tote Bin Pack - Four - 4"H x 20.875"L x 12.74"W and One - 6"H x 20.875"L x 12.74"W	\$274
BINPK4	Clear Tote Bin - 4"H x 20.875"L x 12.74"W Pack of 6	\$308
BINPK6	Clear Tote Bin - 6"H x 20.875"L x 12.74"W Pack of 6	\$412

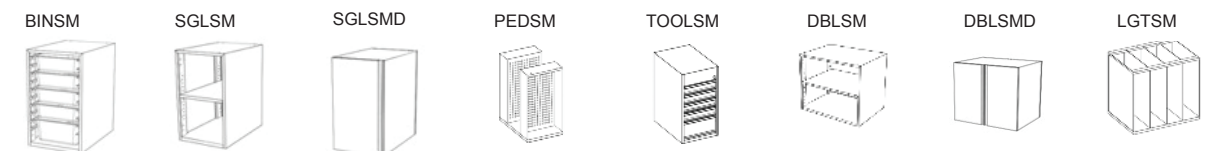

Note: Cargo carts ship KD: Storage modules are shipped assembled except doors need to be attached onsite when applicable.
Freight Class 150 Origin zip 49548
* S - Standard Lead Time 4-6 weeks

Explorer Series®

cargo cart configured

DESCRIPTION	ITEM #	D	W	H	PRICE	SHIP WT.	LEAD TIME*
Cargo Cart with 22d x 77w butcher block top, 1 double storage module with door, 1 single storage module with doors, 1 double storage module with doors and locking casters.	CG2D2DD2.2277	22"	77.5"	35.5"	\$6310	421	*

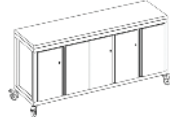

Cargo Cart with 22d x 77w butcher block top, 1 double storage module without doors, 1 single storage module without doors, 1 double storage module without doors and locking casters.	CG2S2SS2.2277	22"	77.5"	35.5"	\$5218	368	*
---	---------------	-----	-------	-------	--------	-----	---

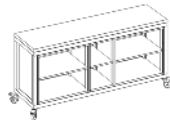

Explorer Series®

cargo cart build your own

DESCRIPTION	ITEM #	D	W	H	PRICE	SHIP WT.	LEAD TIME*
Cargo Cart with 22d x 46w butcher block top and locking casters. Add up to 5 storage modules, sold separately.	CG1xxxx.2246	22"	77.5"	35.5"	\$2688	190	S

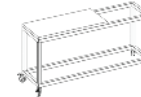

Cargo Cart with 22d x 77w butcher block top and locking casters. Add up to 5 storage modules (L2 large format storage model not an option for this unit), sold separately.	CG2xxxx.2277	22"	77.5"	35.5"	\$2988	230	S
--	--------------	-----	-------	-------	--------	-----	---

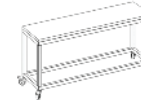

How to Build Your Own item number
 replace "x" with storage module item number listed below.
 Leave "x" for empty modules (positions are laid out left to right)

example (bin storage module, single storage module without door, ped board module, double storage module with locking doors)

B S P D 2
 P1 P2 P3 P4 P5

Configurations: Five 14.7"W Modules
 Two 29.4"W Modules + One 14.7"W Module
 One 29.4"W Module + Three 14.7"W Modules
 29.4"W Modules use 2 positions

to order

1. Item Number
 2. Paint Finish
 See paint finish options for frame below

example **CG2BBBL2.2246 - GA**

ITEM NUMBER PAINT FINISH

please separate each item with a dash

to order

1. Item Number
 2. Paint Finish
 See paint finish options for frame below

example **CG1BSPD2.2277 - GA**

ITEM NUMBER PAINT FINISH

please separate each item with a dash

storage modules platinum finish only		paint finish options for frame	
MODEL	DESCRIPTION	MODEL	DESCRIPTION
B = BINSM	Bin Storage Module- 14.7"W x 21.75"d x 24.5"H with bins Four - 4"H x 20.875"L x 12.74"W and One - 6"H x 20.875"L x 12.74"W	GA	Green Apple
S = SGLSM	Single Storage Module - 14.7"W x 21.75"d x 24.5"H	EN	Navy
D = SGLSMD	Single Storage Module w/ locking doors - 14.7"W x 21.75"d x 24.5"H	P2	Textured Platinum
P = PEGSM	Peg Board Module - 14.7"W x 21.75"d x 24.5"H		
T = TOOLSM	Tool Storage Module - 14.7"W x 21.75"D x 24.5"H		
S2 = DBLSM (uses 2 positions)	Double Storage Module without doors - 29.4"W x 21.75"D x 24.5"H		
D2 = DBLSMD (uses 2 positions)	Double Storage Module w/ locking doors - 29.4"W x 21.75"D x 24.5"H		
L2 = LGFTSM (uses 2 positions)	Large Format Storage Module - 29.4"W x 21.75"D x 24.5"H Large Format Storage Module can only be used with CG2 partial top model.		

to order additional bins		
MODEL	DESCRIPTION	PRICE
BINPK46	Clear Tote Bin Pack - Four - 4"H x 20.875"L x 12.74"W and One - 6"H x 20.875"L x 12.74"W	\$274
BINPK4	Clear Tote Bin - 4"H x 20.875"L x 12.74"W Pack of 6	\$308
BINPK6	Clear Tote Bin - 6"H x 20.875"L x 12.74"W Pack of 6	\$412



Note: Cargo carts ship KD: Storage modules are shipped assembled except doors need to be attached onsite when applicable.
 Freight Class 150 Origin zip 49548
 * S - Standard Lead Time 4-6 weeks

storage modules platinum finish only			
MODEL	DESCRIPTION	PRICE	SHIP WT
B = BINSM	Bin Storage Module- 14.7"W x 21.75"d x 24.5"H with clear tote bin pack Four - 4"H x 20.875"L x 12.74"W and One - 6"H x 20.875"L x 12.74"W	\$908	37
S = SGLSM	Single Storage Module without door- 14.7"W x 21.75"d x 24.5"H	\$554	38
D = SGLSMD	Single Storage Module w/ locking door - 14.7"W x 21.75"d x 24.5"H	\$758	49
P = PEGSM	Peg Board Module - 14.7"W x 21.75"d x 24.5"H (Doesn't include pegs or spools)	\$648	31
T = TOOLSM	Tool Storage Module - 14.7"W x 21.75"D x 24.5"H	\$1098	
S2 = DBLSM (uses 2 positions)	Double Storage Module without doors - 29.4"W x 21.75"D x 24.5"H	\$838	50
D2 = DBLSMD (uses 2 positions)	Double Storage Module w/ locking doors - 29.4"W x 21.75"D x 24.5"H	\$1282	71
L2 = LGFTSM (uses 2 positions)	Large Format Storage Module - 29.4"W x 21.75"D x 24.5"H Large Format Storage Module can only be used with CG2 partial top model.	\$898	72

to order additional bins		
MODEL	DESCRIPTION	PRICE
BINPK46	Clear Tote Bin Pack - Four - 4"H x 20.875"L x 12.74"W and One - 6"H x 20.875"L x 12.74"W	\$274
BINPK4	Clear Tote Bin - 4"H x 20.875"L x 12.74"W Pack of 6	\$308
BINPK6	Clear Tote Bin - 6"H x 20.875"L x 12.74"W Pack of 6	\$412



Note: Cargo carts ship KD: Storage modules are shipped assembled except doors need to be attached onsite when applicable.
 Freight Class 150 Origin zip 49548
 * S - Standard Lead Time 4-6 weeks

Explorer Series®

cargo cart build your own

DESCRIPTION	ITEM #	D	W	H	PRICE	SHIP WT.	LEAD TIME*
Cargo Cart with 28d x 77w butcher block top, 6" overhang on one side and locking casters. Add up to 5 storage modules (L2 large format storage model not an option for this unit), sold separately.	CG3xxxxx.2877	28"	77.5"	35.5"	\$3138	230	S

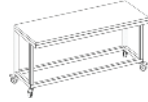

to order How to Build Your Own item number

replace "x" with storage module item number listed below. Leave "x" for empty modules (positions are laid out left to right)

example (bin storage module, single storage module without door, ped board module, double storage module with locking doors)

B S P D 2

P1 P2 P3 P4 P5

Configurations: Five 14.7"W Modules
Two 29.4"W Modules + One 14.7"W Module
One 29.4"W Module + Three 14.7"W Modules
29.4"W Modules use 2 positions

to order 1. Item Number
2. Paint Finish

See paint finish options for frame below

example CG1BSPD2.2277 - GA

ITEM NUMBER PAINT FINISH

please separate each item with a dash

storage modules platinum finish only

MODEL	DESCRIPTION	PRICE	SHIP WT
B = BINSM	Bin Storage Module- 14.7"W x 21.75"D x 24.5"H with clear tote bin pack Four - 4"H x 20.875"L x 12.74"W and One - 6"H x 20.875"L x 12.74"W	\$908	37
S = SGLSM	Single Storage Module without door- 14.7"W x 21.75"D x 24.5"H	\$554	38
D = SGLSMD	Single Storage Module w/ locking door - 14.7"W x 21.75"D x 24.5"H	\$758	49
P = PEGSM	Peg Board Module - 14.7"W x 21.75"D x 24.5"H (Doesn't include pegs or spools)	\$648	31
T = TOOLSM	Tool Storage Module - 14.7"W x 21.75"D x 24.5"H	\$1098	
S2 = DBLSM (uses 2 positions)	Double Storage Module without doors - 29.4"W x 21.75"D x 24.5"H	\$838	50
D2 = DBLSMD (uses 2 positions)	Double Storage Module w/ locking doors - 29.4"W x 21.75"D x 24.5"H	\$1282	71
L2 = LGTSM (uses 2 positions)	Large Format Storage Module - 29.4"W x 21.75"D x 24.5"H Large Format Storage Module can only be used with CG2 partial top model.	\$898	72

to order additional bins

MODEL	DESCRIPTION	PRICE
BINPK46	Clear Tote Bin Pack - Four - 4"H x 20.875"L x 12.74"W and One - 6"H x 20.875"L x 12.74"W	\$274
BINPK4	Clear Tote Bin - 4"H x 20.875"L x 12.74"W Pack of 6	\$308
BINPK6	Clear Tote Bin - 6"H x 20.875"L x 12.74"W Pack of 6	\$412

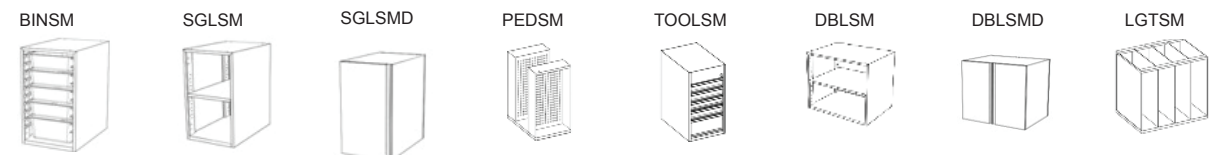

Note: Cargo carts ship KD: Storage modules are shipped assembled except doors need to be attached onsite when applicable.

Freight Class 150 Origin zip 49548

* S - Standard Lead Time 4-6 weeks

Explorer Series®

tall storage cart - specifications

OVERALL DIMENSIONS

47x26.5x66

BODY

Construction
18 Gauge Formed and Welded Steel

MARKERBOARD

Dimensions
47Wx41.5H, Bottom 24.5 from floor
Surface
Non-Ghosting Powder Coat

STORAGE

4 Shelf Configuration (Fixed)

- Shelf Dimension
45Wx21.5Dx14H

8 Shelf Configuration (Optional)

- Shelf Dimension
45Wx21.5Dx6.5H

- Fits 24, 6in bins
3 bins per shelf
8 shelves

6in Bin

- Dimensions
20.875x12.75x6
- 20.6 qt
- Clear
- Polycarbonate
- Dishwasher Safe
- Freezer Safe

CASTERS

4 - 3" Locking Directional Total Lock

- High Strength Steel
- TPU Tread, Non-Marking
- Corrosion Resistant
- 250lb load rating (per caster)

SPECIFICATIONS

Max Load
TBD
Paint
Textured Powder coat



FRONT VIEW

SIDE VIEW

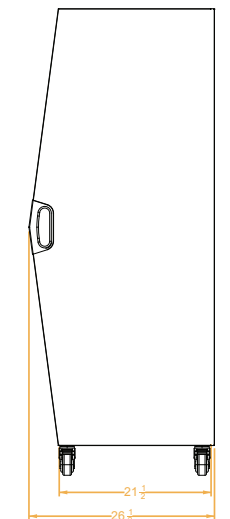
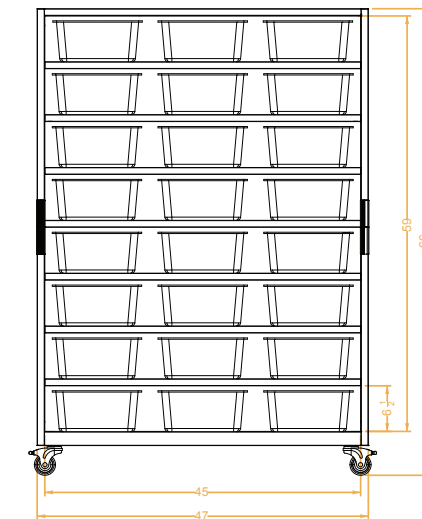

BACK VIEW

TOP VIEW

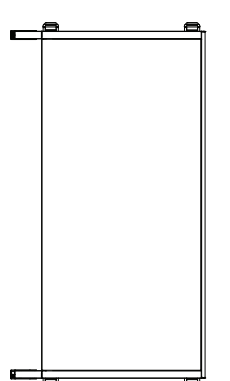
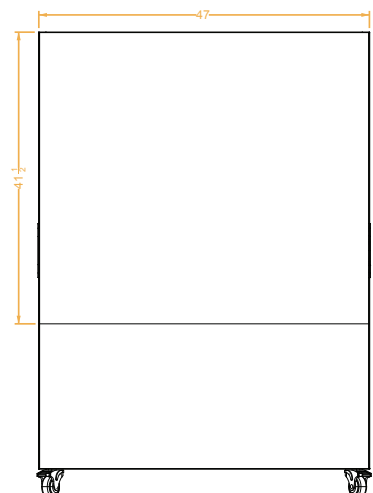

Explorer Series®

cubby storage cart - specifications

OVERALL DIMENSIONS

47x26.5x38

BODY

Construction

18 Gauge Formed and Welded Steel

MARKERBOARD

Dimensions

47Wx34H, Bottom 4IN from floor

Surface

Non-Ghosting Powder Coat

STORAGE

2 Shelf Configuration (Fixed)

Shelf Dimension: 45Wx21.5Dx15H

4 Shelf Configuration (Optional)

Shelf Dimension: 45Wx21.5Dx17H

- Fits 12, 6in bins

- 3 bins per shelf

- 4 shelves

6in Bin

Dimensions: 20.875x12.75x6

- 20.6 qt

- Clear

- Polycarbonate

- Dishwasher Safe

- Freezer Safe

CASTERS

4 - 3" Locking Directional Total Lock

- High Strength Steel

- TPU Tread, Non-Marking

- Corrosion Resistant

- 250lb load rating (per caster)

SPECIFICATIONS

Max Load

TBD

Paint

Textured Powder coat

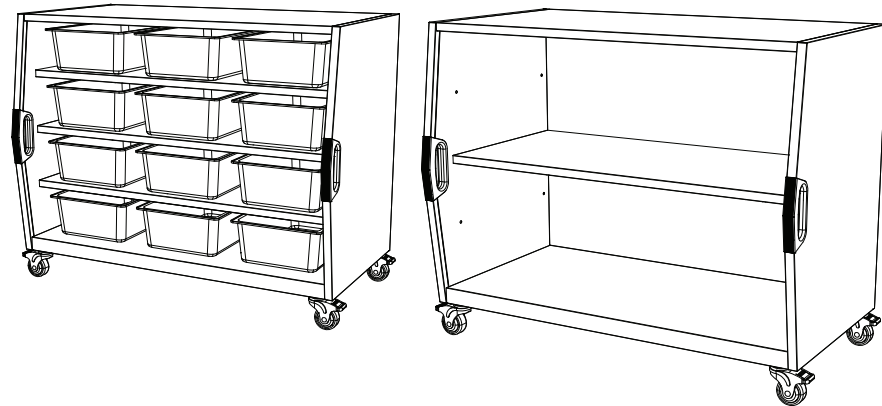

FRONT VIEW

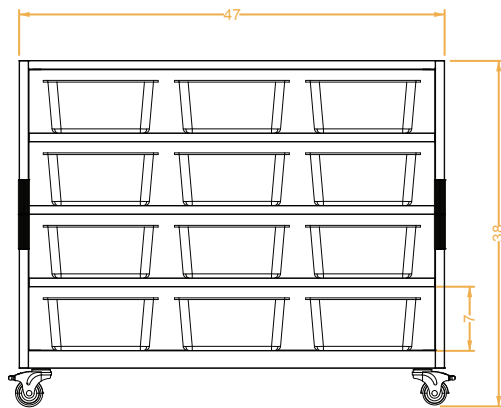

TOP VIEW

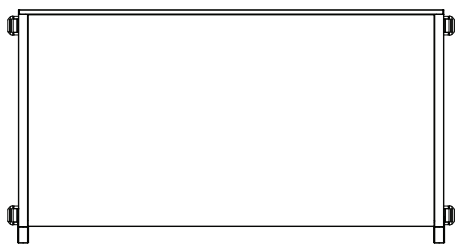

BACK VIEW

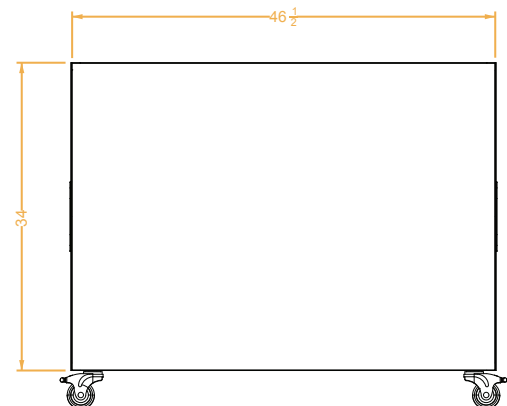

SIDE VIEW

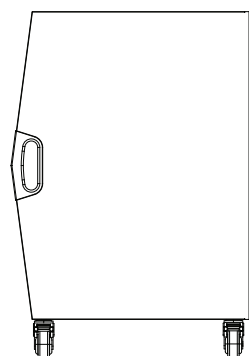

Explorer Series®

pack cart - specification

OVERALL DIMENSIONS

52x26.5x66

BODY

Construction

18 Gauge Formed and Welded Steel

MARKERBOARD

Dimensions

52Wx41.5H, Bottom 24.5 from floor

Surface

Non-Ghosting Powder Coat

STORAGE

Inside Dimension

45x21.5x59

HOOKS

Dimensions

- Lower Hook: 30H

- Upper Hook: 65.5H

Construction

- Welded Steel Construction

- 2 - 6 Hook independent swiveling units

- Max Load per hook: TBD

- 360 degree swivel

- Powder coated

CASTERS

4 - 3" Locking Directional Total Lock

- High Strength Steel

- TPU Tread, Non-Marking

- Corrosion Resistant

- 250lb load rating (per caster)

SPECIFICATIONS

Max Load

- TBD

Paint

- Textured Powder coat

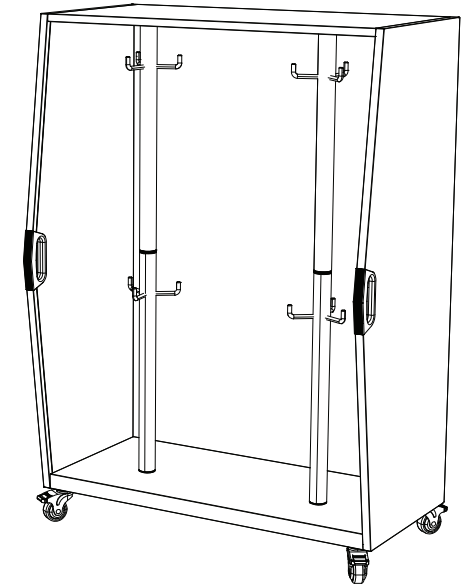

FRONT VIEW

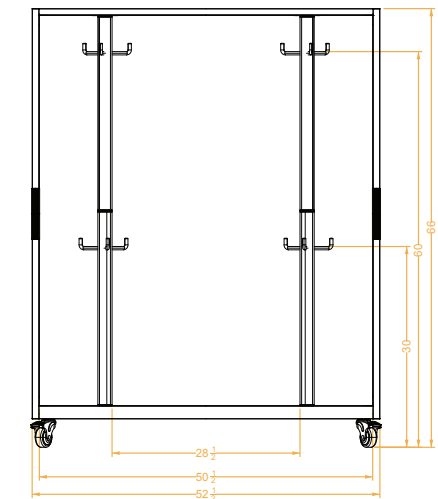

BACK VIEW

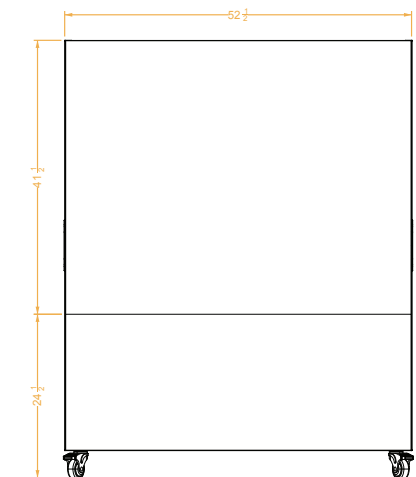

SIDE VIEW

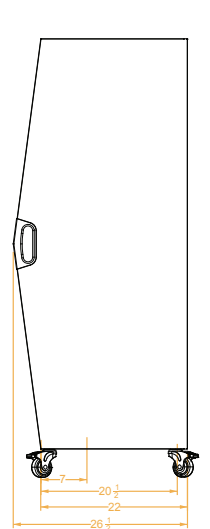



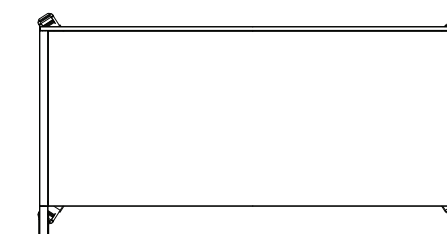

TOP VIEW

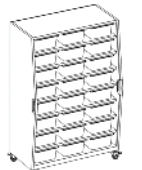

Explorer Series®

storage carts

DESCRIPTION	ITEM #	D	W	H	PRICE	SHIP WT.	LEAD TIME*
Cubby Storage Cart w/ 2 shelves, magnetic white board backing & locking casters.	CUB01	26.5"	47"	38"	\$2568	193	S
							
Cubby Storage Cart w/ 1 fixed and 2 adjustable shelves, 12 - 6" bins, magnetic white board backing & locking casters	CUB02	26.5"	47"	38"	\$3498	193	S
							
Tall Storage Cart w/ 1 fixed and 2 adjustable shelves, magnetic white board backing & locking casters	TSTOR01	26.5"	47"	66"	\$3688	264	S
							
Tall Storage Cart w/ 1 fixed and 6 adjustable shelves, 24 - 6" bins magnetic white board backing & locking casters	TSTOR02	26.5"	47"	66"	\$5488	326	S
							
Pack Storage Cart w/ 2 rotating columns w/ 12 hooks, magnetic white board backing & locking casters	PACKCART	26.5"	52"	66"	\$3418	283	S
							

to order

1. Item Number
2. Paint Finish
See paint finish options for frame below

example

CUB01 - P2 (TEXTURED PLATINUM ONLY)

ITEM NUMBER PAINT FINISH

please separate each item with a dash

to order additional bins

MODEL	DESCRIPTION	PRICE
BINPK6	Clear Tote Bin - 6"H x 20.875"L x 12.74"W Pack of 6	\$412

Ships fully assembled including casters
Freight Class 175 Origin zip 49548
* S - Standard Lead Time 4-6 weeks

Explorer Series®

introduction - think nook™



THINK NOOK™



MARKER BOARD BACK

General
Academic success goes hand in hand with social and emotional learning. As such, the emerging design criteria for today's collaborative classroom should contain a multitude of tools designed to help teachers build their students strengths, enhance their learning styles and support healthy transitions between group work and individualized learning. The Explorer Series® Think Nook™ is the perfect solution for students who need quiet time to think, read or simply recharge.

Explorer Series®

think nook™ - specifications

OVERALL DIMENSIONS

47x26.5x66

BODY

Construction

18 Gauge Formed and Welded Steel

MARKERBOARD

Dimensions

47Wx41.5H, Bottom 24.5 from floor

Surface

Non-Ghosting Powder Coat

POWER (OPTIONAL)

MiniTap

- Manufacturer : Byrne
- 1 110v Power, 2 US Rating
- 13 amps, 125 volts

Cord Length

8ft

SEAT

Inside Seat Dimension

44.5x20x49

PAD

- Seat

1in 2880 Polyurethane Foam

- Back

.25in 2880 Polyurethane Foam

- Headboard

.25in 2880 Polyurethane Foam

MAX LOAD

TBD

FABRIC

COM Yardage Requirements

- Seat: 1.75 Linear Yards
- Back: 1.6 Linear Yards
- Headboard: 1.75 Linear Yards

STORAGE

Inside dimensions

- Outer cubby
15.5Wx7Hx20D
- Center Cubby
12Wx7Hx20D

CASTERS

- 4 - 3" Locking Directional Total Lock
- High Strength Steel
- TPU Tread, Non-Marking
- Corrosion Resistant
- 250lb load rating (per caster)

SPECIFICATIONS

Max Load

TBD

Paint

Textured Powder coat

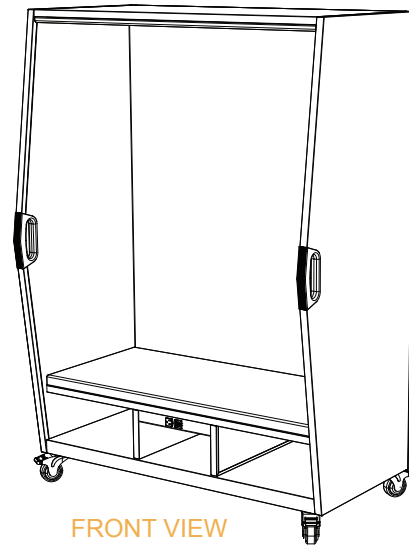

FRONT VIEW

SIDE VIEW

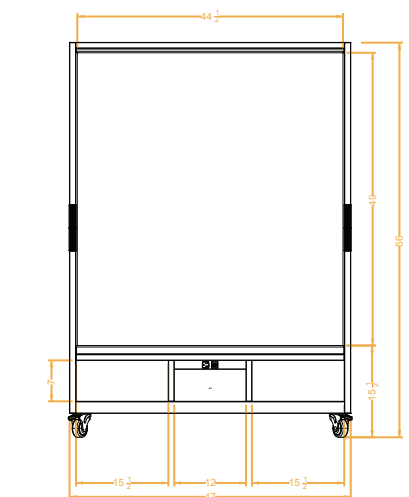

BACK VIEW

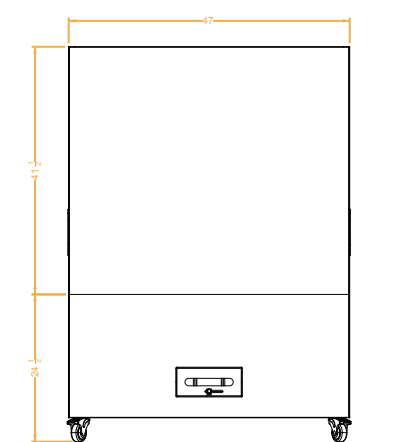
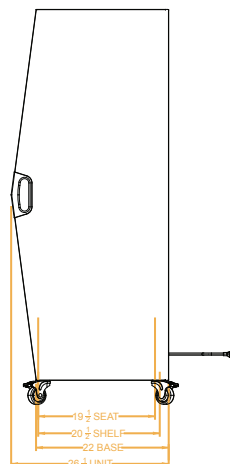

TOP VIEW

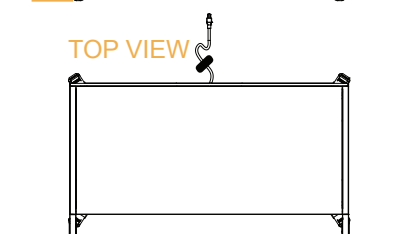

Explorer Series®

think nook™ - fabric planner

For Purchase Order Number:

Project Name:

Headboard: 1 Linear Yard

Fabric Manufacturer:

Fabric Pattern:

Fabric Color:

Back: 2 Linear Yards

Fabric Manufacturer:

Fabric Pattern:

Fabric Color:

Seat: 1 Linear Yard

Fabric Manufacturer:

Fabric Pattern:

Fabric Color:

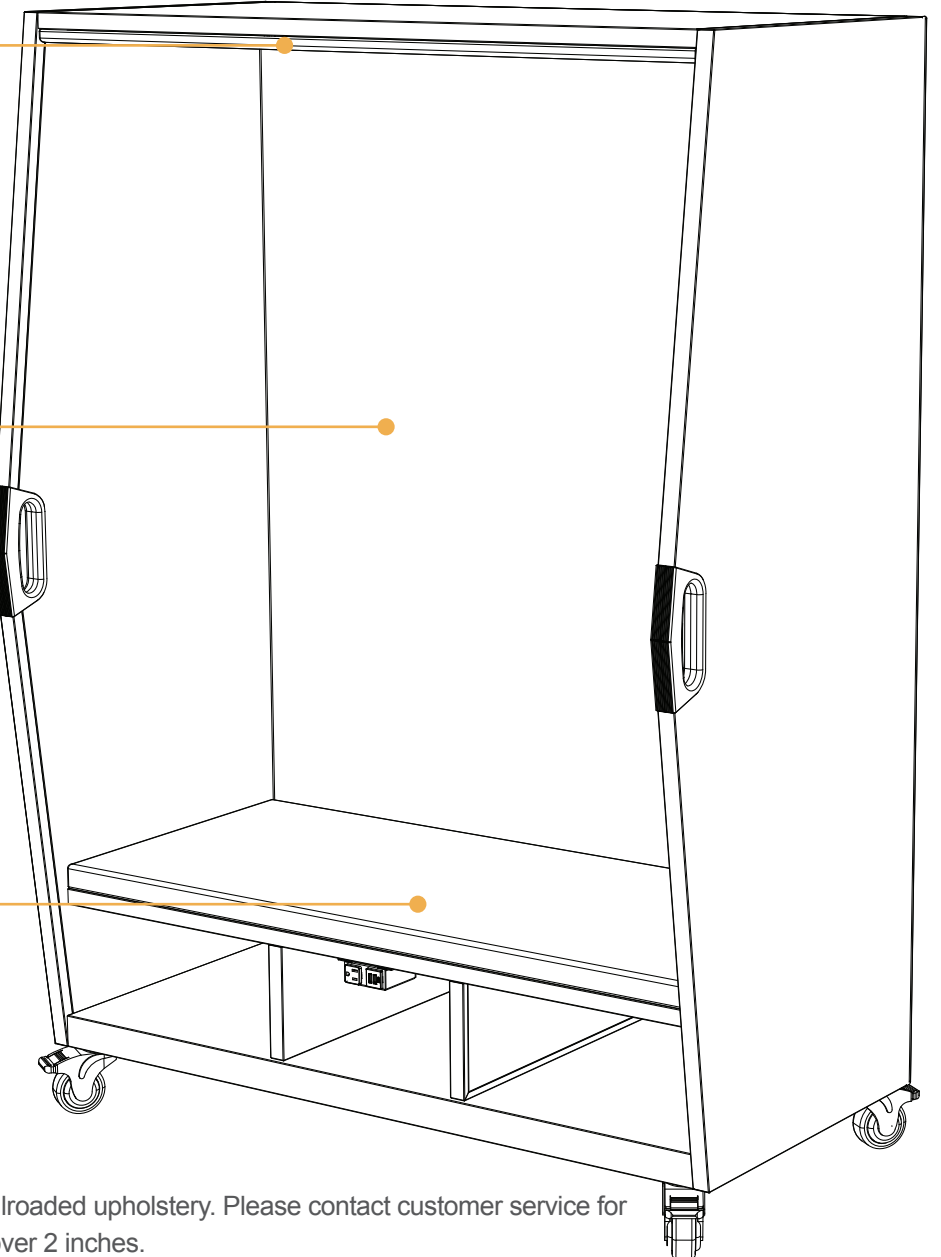

Yardage requirements are for non-railroaded upholstery. Please contact customer service for railroading requirements or repeats over 2 inches.

This form must accompany your order. Send completed form to sales@haskelloffice.com

The lead-time of your order is directly related to when the COM fabric is received.

Please ship COM to: Haskell, 3770 Hagen Dr., Wyoming, MI 49548

Clearly label all materials with the dealer name, project name, and purchase order number.

[Download the COM Fabric Planner for Think Nook™](#)

Explorer Series®

think nook™

DESCRIPTION	ITEM #	NOTE	D	W	H	COM PRICE	SHIP WT.	LEAD TIME*
Nook w/ upholstered seat, back & ceiling, cubby storage, magnetic white board backing & locking casters	THKNK01	Go to www.haskell.com to download COM form COM form must accompany your order	26.5"	47"	66"	\$4924	309	*
Nook w/ upholstered seat, back & ceiling, cubby storage, power unit, magnetic white board backing & locking casters	THKNK01E	Go to www.haskell.com to download COM form COM form must accompany your order	26.5"	47"	66"	\$5488	309	*

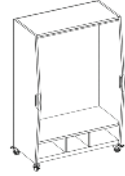

Fuzion™ Series

introduction



General

Haskell's unique sit to stand student desk is the right choice for today's active learning classroom. Our 20 year warranty on the height adjustable column insures years of uninterrupted use in the classroom promoting a healthier learning environment while fostering greater student engagement.

Whether sitting in a chair or standing, nothing gets in your way for maximum comfort. The FuZion™ has two east/west bars and north/south bars for strength and stability.

While many sit to stand desks bounce and are springy (causing the product to wear down after just a few years), our Hydraulic SureLock Construction prevents bounce and slippage of the height adjust.

The addition of an easy grip handle for raising and lowering the sit to stand desk makes height adjustment simple and fast.

The FuZion™ Sit to Stand Desk offers a large laptop storage area under the work surface.

A multi-purpose storage area on the top of the desk helps you maximize your work area and securely hold your tablet for viewing videos or reading.

The water bottle holder helps keep your classroom organized and minimize spills on the floor and on technology while not sacrificing work space.

to order	1. Item Number	THKNK01E	-	P2	-	OR	COM
	2. Paint Finish	ITEM NUMBER		PAINT FINISH		FABRIC CODE	COM
	3. Fabric Code or COM			Textured Platinum (only option)			Customer Supplying Material

please separate each item with a dash
Go to www.haskell.com to download COM form. COM form must accompany your order.

Note: COM Requirements: Headboard 1 linear yard; back 2 linear yards; seat 1 linear yard. Yardage requirements are for non-railroaded upholstery. Please contact customer service for railroading requirements or repeats over 2 inches.

Ships fully assembled including casters

Freight Class 175 Origin zip 49548

* Instock fabric - S – Standard Lead Time 4-6 weeks / COM fabric - 4-6 weeks upon receipt of customer's material

Fuzion™ Series

sit to stand

DESCRIPTION	ITEM #	D	W	H	3MM EDGE	SHIP WT.	LEAD TIME*
Fuzion™ Sit to Stand, 22x26, Formica fog (FF) laminate, fog (FG) edge, platinum paint finish Y base, grommet, locking casters	2FZPN7GQS.2226.PL.FF.FG.0	22"	26"	28 1/4" - 42"	\$830	40	QS
Sit to Stand, 22x26, standard Wilsonart laminate, platinum paint finish Y base, locking casters	2FZPN7.2226.PL	22"	26"	28 1/4" - 42"	\$975	40	S
Sit to Stand, 22x26, standard Wilsonart laminate, platinum paint finish Y base, grommet, locking casters	2FZPN7G.2226.PL	22"	26"	28 1/4" - 42"	\$1010	40	S
Fuzion Sit to Stand, 24x28.5, standard Wilsonart laminate, platinum paint finish Y base, locking casters	2FZPN7.2428.PL	24"	28.5"	28 1/4" - 42"	\$1018	40	S
Fuzion Sit to Stand, 24x28.5, standard Wilsonart laminate, platinum paint finish Y base, grommet, locking casters	2FZPN7G.2428.PL	24"	28.5"	28 1/4" - 42"	\$1050	40	S
Large Sit to Stand, 28x36, standard Wilsonart laminate, platinum paint finish base, locking casters. Can be used as an ADA desk.	FZPN8.2836.PL	28"	36"	28 1/4" - 42"	\$1244	62	S
Large Sit to Stand, 28x36, standard Wilsonart laminate, platinum paint finish base, grommet, locking casters. Can be used as an ADA desk.	FZPN8G.2836.PL	28"	36"	28 1/4" - 42"	\$1278	62	S

to order

- Item Number
- Laminate
- Edge Finish
- Options

example

FZPN7G.2226-PL - GL - 63 - BKSHF

ITEM NUMBER - LAMINATE - EDGE FINISH - OPTIONS
PL Platinum Paint Finish (only option)

please separate each item with a dash

MODEL	DESCRIPTION	PRICE
BKSHF	BOOK SHELF / LAPTOP HOLDER <small>Only available in platinum</small>	\$94



FZPNMOD.2226	MODESTY PANEL FOR 22X26 SIT TO STAND	\$144
--------------	--------------------------------------	-------

Fuzion™ Series

ADA height adjustable desk

DESCRIPTION	ITEM #	D	W	H	3MM EDGE	SHIP WT.	LEAD TIME*
Fuzion ADA height adjustable desk, 30x36, standard Wilsonart laminate, platinum paint finish base, locking casters.	FZPN9.3036.PL	30"	36"	28 1/4" - 42"	\$1320	62	S
Fuzion ADA height adjustable desk, 30x36, standard Wilsonart laminate, platinum paint finish base, grommet, locking casters.	FZPN9G.3036.PL	30"	36"	28 1/4" - 42"	\$1358	62	S

to order

- Item Number
- Laminate
- Edge Finish
- Options

example

FZPN9G.3036-PL - H - I

ITEM NUMBER - LAMINATE - EDGE FINISH
PL Platinum Paint Finish (only option)

please separate each item with a dash







MODEL	DESCRIPTION	PRICE
BKSHF	BOOK SHELF / LAPTOP HOLDER <small>Only available in platinum</small>	\$94

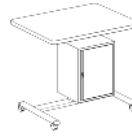

FZPNMOD	FOR 22X26 SIT TO STAND	\$144
---------	------------------------	-------

Fuzion™ Series

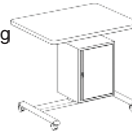
teacher's lectern with storage

DESCRIPTION	ITEM #	D	W	H	3MM EDGE	SHIP WT.	LEAD TIME*
Teacher's Lectern, 22x26, hydraulic lift, locking storage cabinet, platinum Y base, locking casters 	2FZTL7.2226.PL	22"	26"	28 1/4" - 42"	\$1465	64	S
Teacher's Lectern, 22x26, hydraulic lift, grommet, locking storage cabinet, platinum Y base, locking casters 	2FZTL7G.2226.PL	22"	26"	28 1/4" - 42"	\$1522	64	S
Fuzion Teacher's Lectern, 24x28, hydraulic lift, locking storage cabinet, platinum Y base, locking casters 	2FZTL7.2428.PL	22"	28.5"	28 1/4" - 42"	\$1528	64	S
Fuzion Teacher's Lectern, 24x28, hydraulic lift, grommet, locking storage cabinet, platinum Y base, locking casters 	2FZTL7G.2428.PL	22"	28.5"	28 1/4" - 42"	\$1560	64	S
Large Teacher's Lectern, 28x36, hydraulic lift, locking storage cabinet, platinum base, locking casters 	FZTL8.2836.PL	28"	36"	28 1/4" - 42"	\$1754	86	S
Large Teacher's Lectern, 28x36, hydraulic lift, grommet, locking storage cabinet, platinum base, locking casters 	FZTL8G.2836.PL	28"	36"	28 1/4" - 42"	\$1788	86	S

to order

- Item Number
- Paint Finish
- Laminate
- Edge Finish

example 2FZTL7.2226 - PL - H - I

ITEM NUMBER PAINT FINISH LAMINATE EDGE FINISH
 PL Platinum Paint Finish (only option)



please separate each item with a dash

options

MODEL	DESCRIPTION
PL	Platinum Only available in platinum

Fuzion™ Series

teacher's desk

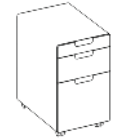
DESCRIPTION	ITEM #	D	W	H	3MM EDGE	SHIP WT.	LEAD TIME*
Fuzion™ Wave shape, right handed (podium connects on right convex side) static t-leg, 30x60, modesty panel, grommet, platinum paint and casters. Concave podium ordered separately. 	FZRWAVEC.3060.PL	30"	60"	29.5"	\$1620	94	S
Fuzion™ Wave shape, left handed (podium connects on left convex side) static t-leg, 30x60, modesty panel, grommet, platinum paint and casters. Concave podium ordered separately. 	FZLWAVEC.3060.PL	30"	60"	29.5"	\$1620	94	S
Fuzion™ Wave concave podium, 31x36, sit to stand hydraulic lift, platinum paint finish Y base and casters 	2FZWVBP.2630.PL	31"	36"	28 1/4" - 42"	\$1124	54	S
Fuzion™ mobile pedestal, tray/box/file, platinum paint 	FZTBFPEP-PL	20.78"	14.75"	22.9"	\$790	48	S
Center drawer, 23" w, platinum paint	CD27-PL	17 1/8"	23"	3"	\$320	5	S

to order

- Item Number
- Laminate
- Edge Finish

example FZRWAVE.3060.PL - H - I

ITEM NUMBER LAMINATE EDGE FINISH
 PL Platinum Paint Finish (only option)

please separate each item with a dash

Fuzion™ Series

teacher's desk

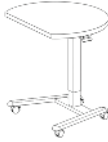
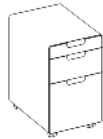
DESCRIPTION	ITEM #	NOTES	D	W	H	PRICE	SHIP WT.	LEAD TIME*
Rectangular shape, static t-leg, modesty panel, grommet, platinum paint and casters 	FZRECTC.2448.PL		24"	48"	29.5"	\$1384	78	S
	FZRECTC.2460.PL		24"	60"	29.5"	\$1468	86	S
	FZRECTC.3048.PL		30"	48"	29.5"	\$1484	86	S
	FZRECTC.3060.PL		30"	60"	29.5"	\$1554	94	S
D shape podium, sit to stand hydraulic lift, platinum paint finish Y base and casters 	2FZDP24.PL		24"	30"/24"	28 1/4" - 42"	\$1034	44	S
	2FZDP30.PL		30"	36"/30"	28 1/4" - 42"	\$1088	\$60	S
Fuzion™ mobile pedestal, tray/box/file, platinum paint 	FZTBFPEP-PL		20.78"	14.75"	22.9"	\$790	48	S
Center drawer, 23" w, platinum paint	CD27-PL		17 1/8"	23"	3"	\$320	5	S

to order

1. Item Number
2. Laminate
3. Edge Finish

example

FZRECTC.2448-PL - H - I

ITEM NUMBER - LAMINATE - EDGE FINISH
 PL Platinum Paint Finish (only option)

please separate each item with a dash

Fuzion™ Series

teacher's desk

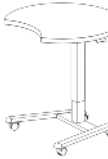
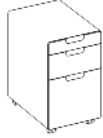
DESCRIPTION	ITEM #	NOTES	D	W	H	PRICE	SHIP WT.	LEAD TIME*
Kidney shape, static t-leg, 33X60, modesty panel, grommet, platinum paint and casters 	FZKIDC.3360-PL		33"	60"	29.5"	\$1864	98	S
3/4 moon shape podium, 27x30, sit to stand hydraulic lift, platinum paint finish Y base and casters 	FZMP.2730-PL		27"	30"	28 1/4" - 42"	\$1088	40	S
Fuzion™ mobile pedestal, tray/box/file, platinum paint 	FZTBFPEP-PL		20.78"	14.75"	22.9"	\$790	48	S
Center drawer, 23" w, platinum paint	CD27-PL		17 1/8"	23"	3"	\$320	5	S

to order

1. Item Number
2. Laminate
3. Edge Finish

example

FZKIDC.3360-PL - H - I

ITEM NUMBER - LAMINATE - EDGE FINISH
 PL Platinum Paint Finish (only option)

please separate each item with a dash

Fuzion™ Series

teacher's desk

DESCRIPTION	ITEM #	NOTES	D	W	H	PRICE	SHIP WT.	LEAD TIME*
Fuzion Mobile Teacher's Desk 24" x 60" with Box/Box/File mobile pedestal, T- legs and modesty panel	FZTD.2460.PL		24"	60"	29"	\$1578	107	S
Fuzion Mobile Teacher's Desk 24" x 66" D-shaped peninsula top with Box/Box/File mobile pedestal, T- legs and modesty panel	FZTDD.2466.PL		24"	66"	29"	\$1678	107	S

Marathon Series

introduction



General

All Marathon Desking Units are 30" H. All worksurfaces are laminate wood core tops at 1 3/16" thick and are available with a 3mm edge. All Marathon Desking Units come with center drawers and central locking systems.

Assembly

All units ship without chrome legs attached. Legs can attach with no tools, but come with an added bracket that can be screwed to the bottom of the pedestal for additional support. Interior drawer accessories are field-installed only.

Locks

Marathon Desking Units comes standard with a removable core lock for easy reconfiguration on site. Units can be keyed alike to other Haskell products upon request.

Installation

Correct installation should include proper leveling.

Application Considerations

When specifying the units for workstation configurations, note the following points:

*18" D returns can be used for the 66" x 30" or wider single pedestal desks.

*Overstorage Units can not be used on 36" D with overhangs. The 6" overhang is not suitable to support a loaded overstorage unit.

COM

All COM yardage is based on a 54" wide fabric.

Keying Information and Locking Options

All locks feature a removable core which is easily removed on site. All lock cores are interchangeable through all products as cores are universal.

Locks throughout an order or locks within a particular workstation can be keyed alike at no additional charge, if specified when ordering. Keyed Alike means that all locks are identical. To order, specify which products are to be keyed alike and order a "Removable Core Lock Kit" for each group of products to be keyed alike. The specified products will be shipped without lock cores. The cores for each workstation will be packaged separately. All Removable Core Lock Kits are shipped with a control key for removing or inserting lock cores. Note that a control key works only when a lock is in the unlocked position.

Master keys, which operate any removable core lock, are available for \$35 net each.

One control key is provided for each "key alike" order. If additional keys are needed, cost is \$35 net each.

Additional keys can be purchased for \$15 net per key.

to order

1. Item Number
2. Laminate
3. Edge Finish

example

FZKIDC.3360-PL - H - I

ITEM NUMBER LAMINATE EDGE FINISH

PL Platinum Paint Finish (only option)

please separate each item with a dash

Marathon Series

double pedestal desks

DESCRIPTION	ITEM #	D	W	H	3MM EDGE	SHIP WT.	LEAD TIME*
Double Pedestal Desk 6" overhang on side/approach, center drawer w/ central locking system	MDC6036C	36"	60"	30"	\$2214	200	E
	MDC7236C	36"	72"	30"	\$2268	224	E
Double Pedestal Desk locks & center drawer w/ central locking system	MDC6030C	30"	60"	30"	\$2560	190	E
Table Desk locks & center drawer	MTD7236C	36"	72"	30"	\$2654	198	E

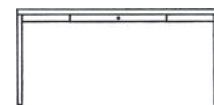
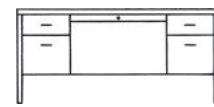
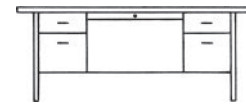

to order

- Item Number
- Pull Style
- Paint Finish
- Edge Finish
- Leg Finish

example MDC6036C - FL - 5503 - 4072 - CH99

ITEM NUMBER PULL STYLE PAINT FINISH EDGE FINISH LEG FINISH

please separate each item with a dash

drawer pull options		leg finish options	
MODEL	DESCRIPTION	FINISH	DESCRIPTION
RS	Recessed	CH99	Chrome
		Paint Finish #	Painted
			10% Upcharge



drawer accessories		
MODEL	DESCRIPTION	PRICE
HABDD	Box Drawer Divider	\$72

Marathon Series

single pedestal desks

DESCRIPTION	ITEM #	NOTE	D	W	H	3MM EDGE	SHIP WT.	LEAD TIME*
Single Pedestal Desk right b/f pedestal & center drawer w/ central locking system	MRC4530C	Not applicable for use w/ returns	30"	45"	30"	\$2302	123	E
	MRC6030C	Not applicable for use w/ returns	30"	60"	30"	\$2374	149	E
Single Pedestal Desk right b/f pedestal & center drawer w/ central locking system	MRC6030C	For use w/18" D return	30"	60"	30"	\$2610	171	E
	MRC7230C	For use w/18" D return	30"	72"	30"	\$2648	192	E
Single Pedestal Desk left b/f pedestal & center drawer w/ central locking system	MLC4530C	Not applicable for use w/ returns	30"	45"	30"	\$2302	123	E
	MLC6030C	Not applicable for use w/ returns	30"	60"	30"	\$2374	149	E
Single Pedestal Desk left b/f pedestal & center drawer w/ central locking system	MLC6030C	For use w/18" D return	30"	60"	30"	\$2610	171	E
	MLC7230C	For use w/ 18" D return	30"	72"	30"	\$2648	192	E

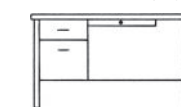
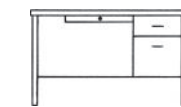
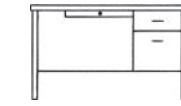

to order

- Item Number
- Pull Style
- Paint Finish
- Edge Finish
- Leg Finish

example MRC4530C - FL - 5503 - 4072 - CH99

ITEM NUMBER PULL STYLE PAINT FINISH EDGE FINISH LEG FINISH

please separate each item with a dash

drawer pull options		leg finish options	
MODEL	DESCRIPTION	FINISH	DESCRIPTION
RS	Recessed	CH99	Chrome
		Paint Finish #	Painted
			10% Upcharge

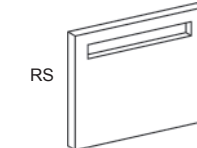

Marathon Series

single pedestal desks w/ overhang

DESCRIPTION	ITEM #	NOTE	D	W	H	3MM EDGE	SHIP WT.	LEAD TIME*
Single Pedestal Desk right b/f pedestal, w/ 6" overhang on approach & center drawer w/ central locking system	MRC6036C	Not applicable for use w/ returns	36"	60"	30"	\$2621	165	E
Single Pedestal Desk left b/f pedestal, w/ 6" overhang on approach & center drawer w/ central locking system	MLC6036C	Not applicable for use w/ returns	36"	60"	30"	\$2621	165	E

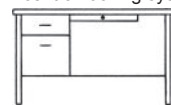
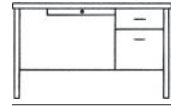

Marathon Series

returns and credenzas

DESCRIPTION	ITEM #	NOTE	D	W	H	3MM EDGE	SHIP WT.	LEAD TIME*
Right Handed Return w/ b/f pedestal	MER4218C	For use w/ 60" & 72" W	18"	42"	30"	\$1752	87	E
	MER6018C	For use w/ 60" & 72" W	18"	60"	30"	\$1778	107	E
Left Handed Return w/ b/f pedestal	MEL4218C	For use w/ 60" & 72" W	18"	42"	30"	\$1752	87	E
	MEL6018C	For use w/ 60" & 72" W	18"	60"	30"	\$1778	76	E
Credenza locks & b/f pedestals	MCK6018		18"	60"	30"	\$2788	150	E

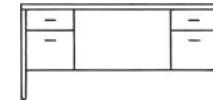

to order

- Item Number
- Pull Style
- Paint Finish
- Edge Finish
- Leg Finish

example **MRC6036C - FL - 5503 - 4072 - CH99**

ITEM NUMBER	PULL STYLE	PAINT FINISH	EDGE FINISH	LEG FINISH
MRC6036C	FL	5503	4072	CH99

please separate each item with a dash

drawer pull options		leg finish options	
MODEL	DESCRIPTION	FINISH	DESCRIPTION
RS	Recessed	CH99	Chrome
		Paint Finish #	Painted
			Standard
			10% Upcharge

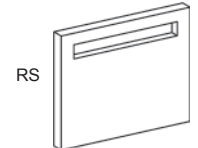

to order

- Item Number
- Pull Style
- Paint Finish
- Edge Finish
- Leg Finish

example **MER4218C - FL - 5503 - 4072 - CH99**

ITEM NUMBER	PULL STYLE	PAINT FINISH	EDGE FINISH	LEG FINISH
MER4218C	FL	5503	4072	CH99

please separate each item with a dash

drawer pull options		leg finish options	
MODEL	DESCRIPTION	FINISH	DESCRIPTION
RS	Recessed	CH99	Chrome
		Paint Finish #	Painted
			Standard
			10% Upcharge



Marathon Series

overstorage units and tackboards

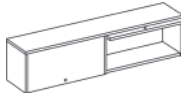
DESCRIPTION	ITEM #	NOTE	COM	D	W	H	PRICE	SHIP WT.	LEAD TIME*
Wall Mounted Overstorage Cabinet 	WM30	Includes mounting hardware		14"	30"	15 1/2"	\$962	56	E
	WM36	Includes mounting hardware		14"	36"	15 1/2"	\$988	61	E
	WM42	Includes mounting hardware		14"	42"	15 1/2"	\$1000	66	E
	WM48	Includes mounting hardware		14"	48"	15 1/2"	\$1012	70	E
	WM60	Includes mounting hardware		14"	60"	15 1/2"	\$1484	89	E
	WM66**	Includes mounting hardware		14"	66"	15 1/2"	\$1950	96	E
	WM72**	Includes mounting hardware		14"	72"	15 1/2"	\$1976	103	E
Wall Mounted Tackboards for overstorage cabinet	SFT3019	Includes mounting hardware	2 YD	1"	30"	22 1/2"	\$810	28	E
	SFT3619	Includes mounting hardware	2 YD	1"	36"	22 1/2"	\$832	38	E
	SFT4219	Includes mounting hardware	2 YD	1"	42"	22 1/2"	\$844	42	E
	SFT4819	Includes mounting hardware	2 YD	1"	48"	22 1/2"	\$858	48	E
	SFT6019	Includes mounting hardware	2 YD	1"	60"	22 1/2"	\$938	68	E
	SFT6619	Includes mounting hardware	2 YD	1"	66"	22 1/2"	\$958	74	E
	SFT7219	Includes mounting hardware	2.5 YD	1"	72"	22 1/2"	\$992	80	E

to order

1. Item Number
2. Paint Finish
3. Fabric (for tackboards only)

example **SOS4219TB - 5503 -**

ITEM NUMBER PAINT FINISH FABRIC/COM

please separate each item with a dash

**WM66 ships as (1) 30" w and (1) 36" w units
 **WM72 ships as (2) 36" w units

Marathon Series

desking accessories

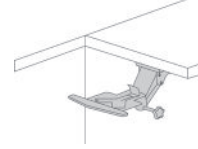
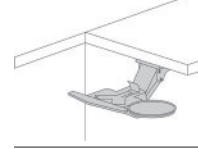
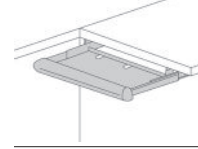
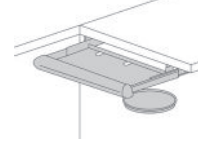
DESCRIPTION	ITEM #	NOTE	PRICE	SHIP WT.	LEAD TIME*
Keyboard Arm 	KB1	Swivels 360 degrees, tils w/ 6" height adjustments Includes wrist rest	\$428	10	S
Keyboard Arm w/ mouse pad 	KB2	Swivels 360 degrees, tils w/ 6" height adjustments Includes wrist rest & mouse pad, for use on left or right	\$484	12	S
Keyboard Tray 	KD1	Steel platform w/ cushion palm rest Steel ball bearing slides	\$634	9	S
Keyboard Tray w/ mouse pad 	KD2	Steel platform w/ cushion palm rest Steel ball bearing slides & mouse pad for use on left or right	\$368	10	S
24" W Task Light	MTL24		\$248	5.5	S
48" W Task Light	MTL48		\$274	7	S

to order

1. Item Number

example **KB1**

ITEM NUMBER

Marathon Series

introduction - seating



General

Haskell's Marathon Series is proud to be U.S. Made in Grand Rapids, Michigan.

Our seating is designed with today's workplace in mind. Superior craftsmanship, outstanding comfort, and produced with the use of recycled materials for sustainability. Our chairs our constant but the people who use them come in all shapes and sizes, that's why our task seating comes with the following features:

- Quick ship available on all Marathon seating
- Fully height adjustable one touch pneumatic height adjustment
- Comfortable waterfall seat construction with contoured foam for all day use
- Adjustable lumbar support which allows the lumbar to hit just the right spot, with vertical and horizontal adjustment
- Adjustable seat depth to fit any size individual
- Marathon chairs have a weight capacity of 300 lbs.
- Durable easy-care fabrics that breath so your body breaths as well
- Marathon chairs swivel 360 degrees
- Durable scuff resistant 5 star base with dual hard wheel casters for strength and mobility
- Synchro Tilt Hardware with back lock and tension adjustable settings
- 24/7 Intensive use chair comes with 3.5" of high-density foam for comfort and durability Intensive use chair is produced for 24/7 use, is extra wide in seat width, has a 3.5" seat of high density foam for comfort and durability and has a weight capacity of 400 lbs., with upholstered seat and back with adjustable active lumbar support.
- Your choice of arms: Vertically adjustable arms with urethane arm pads for comfort and durability or Urethane Fixed Arms when adjustability is not needed
- Marathon Guest/Side chairs stack or next for easy storage
- Task chairs upholstered seats are produced with a molded foam seat with a waterfall edge

- When headrests are used, the headrest fabric will match the seat upholstery
- Task Stools has an adjustable foot ring for ultimate size flexibility
- Nesting Chair is produced with an upholstered seat and a strong flexible polypropylene back, powder coated frame
- All Marathon Series Seating meets ANSI/BIFMA X5.1

When you are making your seating choice you can sit assured that the Marathon Series will provide you with the features that will give you hours of productivity and comfort in the workplace. Comfort and strength is built into every chair. Our seats are over 18" wide and our high back, backs are over 24" high for lots of support. Our standard frame is black and our base is super strong, made of fiberglass reinforced Nylon. Mesh backs material is protected to prevent damage from hard surfaces/edges. Domestic polyurethane arm pads are available with soft long lasting material.

Haskell Environmental Statement

Haskell has provided federal agencies, schools and the contract furniture markets, with furniture that is known for its extra long life cycle. Our furniture is constructed from steel, the most widely recycled material in North America. These products are a key value for Haskell in serving the community, including acting responsibly. In this vein, Haskell has demonstrated an exceptional commitment to Environmental improvement. Haskell has always taken the common sense approach in designing both quality and durability into its products.

- Marathon seating is Green and meets ANSI/BIFMAX7.1 VOC emissions
- All metal components are painted with powder coat
- Marathon seating is produced with over 20% recycled material



Marathon Series

introduction - seating

Steel

Haskell's primary material is steel. Steel is the most recycled post-consumer material used in North America. More steel is recycled than all other metals, paper, glass and plastic combined. The use of recycled steel does not degrade any performance characteristics of steel.

Powder Coating

Haskell's products are designed around the newest steel coating technology. All steel parts and products are coated with powder that is cured in an oven. This offers superior durability and performance while eliminating waste and pollutants. Powder coating is in the enviable position of completely eliminating ozone layer eroding VOC (Volatile Organic Compounds).

Adhesives

In keeping with our powder coating that helps eliminate harmful VOC's. Haskell's Marathon seating incorporates the use of virtually VOC free adhesives when producing our seating product. We follow the stringent Ansi/Bifma M7.1 guidelines set for VOC adhesives. Every step in our process we are evaluating and using methods that eliminate our carbon footprint.

Packaging

Delivery of an undamaged unit on-site is a positive alternative to manufacturing a replacement in terms of energy and materials. For the last three years Haskell has consistently reduced the cardboard content of it's packaging by more than half while decreasing shipping damage. Corrugated cardboard used by Haskell contain at least 25% recycled materials.

...And More

Haskell's manufacturing process and facility is a 99% solvent-free environment and the company is as dedicated to the conservation of our natural resources as it is to the elimination of pollutants. All forklifts have been converted from gasoline to either natural gas or electric power, or have been replaced by electric scissor lifts and gravity fed roller tables.

Marathon Series

task chairs

DESCRIPTION	ITEM #	MESH BACK	UPHOLSTERED BACK	LEATHER	PRICE	LEAD TIME*
High Back Task Chair w/ Integrated Headrest (shown with mesh back and integrated headrest)	SC333	✓	✓		\$1458	*
High Back Task Chair w/ Adjustable Headrest (shown with upholstered back and integrated headrest)	SC355	✓	✓	✓	\$1498	*
Mid Back Task Chair (shown with upholstered back)	SC210	✓	✓		\$1310	*
Mid Back Task Chair (shown with mesh back)	SC220	✓	✓		\$1310	*
Mid Back Rotary Stool (shown with upholstered back)	SC225	✓	✓		\$1526	*
24/7 Intensive Use (shown with upholstered back)	SC247	✓	✓		\$2726	*
Ergonomic Task chair with Flexible back	SC400	✓	✓		\$2288	*

to order

1. Item Number
2. Back Style
3. Fabric Option
4. Arm Style (if applicable)
5. Additional Options (if applicable)

example SC333 - UB - VN - ADO - BA
ITEM NUMBER BACK STYLE FABRIC OPTION ARM STYLE OPTIONS
please separate each item with a dash

back style			arm style			additional options		
CODE	DESCRIPTION		CODE	DESCRIPTION	PRICE	CODE	DESCRIPTION	PRICE
MB	Mesh Back		AD	Adjustable Arm	\$334	AZ	Fully Assembled	\$218
UB	Upholstered Back		ADO	Fixed Arm	\$230	BA	Brushed Aluminum Base	\$208
			AD4	4 way adjustable arm	\$334	BAF	Brushed Aluminum Frame	\$1248
			AD6	Adjustable up/down,in/out,front/back,pivot LFT/RT	\$322	ST	Synchro Tilt	\$252
			AD7	Adjustable polished aluminum arm	\$334	SS	Seat Slider	\$88
			FA	Fixed Arms (black poly or brushed aluminum)	\$302	QS	Quick Ship	\$208
			FP	Full Panel Arm	\$208	HWC	Hard Wheel Casters	\$130
			UC	Upholstered Cap	\$84	SWC	Soft Wheel Casters	\$130
						MPB	Plastic Base	\$146

* Please contact Customer Service for lead time.

Marathon Series

side chairs

DESCRIPTION	ITEM #	MESH BACK	POLYPROPYLENE BACK	UPHOLSTERED BACK	PRICE	LEAD TIME*
Guest Chair	SC100	✓	✓	✓	\$1014	*
Guest Chair with Casters	SC125	✓	✓	✓	\$1152	*
Guest Chair with Casters	SC150	✓	✓	✓	\$1152	*
Nesting Guest Chair with Casters	SC175	✓	✓	✓	\$1326	*

to order

1. Item Number
2. Back Style
3. Fabric Option

example SC100 - UB - GR
ITEM NUMBER BACK STYLE FABRIC OPTION
please separate each item with a dash

back style		fabric options								
CODE	DESCRIPTION	GRADE 1	GRADE 2	GRADE 3	VINYL	LEATHER	MESH BACK			
MB	Mesh Back	CODE DESCRIPTION	CODE DESCRIPTION	CODE DESCRIPTION	CODE DESCRIPTION	CODE DESCRIPTION	CODE DESCRIPTION	CODE DESCRIPTION	CODE DESCRIPTION	CODE DESCRIPTION
PB	Polypropylene Back	AW Alpine White	EB Ebony	SK Sky	AL Ale	CV Caviar	BK Black			
UB	Upholstered Back	BO Black Onyx	EC Eclipse	LN Lunar	BN Black Satin	BL Black	BE Blue			
		BL Cobalt Blue	EM Ember	NG Night	CA Cabernet	CB Coronet Blue	RD Red			
		DY Dark Gray	GL Glint	FL Fall	CD Cordial	CH Chinchilla	GY Gray			
		FG Forest Green	GP Graphite	CH Chile	CR Cream	DG Dark Gray				
		GI Graphite	LS Laser	RB Ruby	FE Feather	DM Demitasse				
		GR Gray	MD Midnight	DB Jazz	HA Harness	IL Illusion				
		SB Steel Blue	ML Moonlight	SF Surf	IC Ice	TN Tan				
		TA Tan	MT Meteor		MI Mist	WH White				
		RD Red	SP Spring		VL Velvet					
			WV Wave		TA Tan					
					WI White					
					GM Dark Gray					

* Please contact Customer Service for lead time.

Marathon Series

guest chairs & sofas

DESCRIPTION	ITEM #	PRICE	LEAD TIME*
Armless Guest Chair	GS25	\$2024	*
Closed Arm Guest Chair	GS50	\$2362	*
Open Arm Guest Chair	GS75	\$2160	*
Lounge Chair	LC100	\$8772	*
Two Seat Sofa	LC222	\$13426	*
Three Seat Sofa	LC333	\$19566	*

to order

- Item Number
- Fabric Option
- Arm Style (if applicable)

example GS25 - VN - AD6

ITEM NUMBER FABRIC OPTION ARM STYLE

please separate each item with a dash

fabric options		arm style	
CODE	DESCRIPTION	CODE	DESCRIPTION
VN	All Vinyl Grades	AD6	ADJ up/down,in/out,front/back,pivot LFT, RT
UB2	Grade 2 Fabric	FP	Full Panel Arm
UB3	Grade 3 Fabric	UC	Upholstered Cap
LT	Leather		
BA	Brushed Aluminum Base		

* Please contact Customer Service for lead time.

Market Series

introduction - pedestals



General

All Market Pedestals are 15" in width. All file drawers are designed to accommodate hanging folders. Mobile units are standard with counterweights to reduce the likelihood of tipping. However, it is recommended that not more than one heavily loaded drawer be opened at one time. Caution should be exercised when pedestals are used as freestanding units.

Assembly

All units ship fully assembled.

Locks

Market Pedestals come standard with a removable core lock for easy reconfiguration on site. Units can be keyed alike to other Haskell Products upon request.

Unit Construction

The Market Series Pedestal and Lateral drawer fronts are external to the case and are referred to as Proud.

Wood Core Tops

Laminate tops are available as a separate component. Tops are available with a 3mm edge. All wood core tops are 1 1/8" thick.

Casters/Glides

Market Pedestals are available with either adjustable glides or casters. Casters and glides are easily interchangeable in the field.

COM

All COM yardage is based on a 54" wide fabric.

Keying Information and Locking Options

All locks feature a removable core which is easily removed on site. All lock cores are interchangeable through all products as cores are universal.

Locks throughout an order or locks within a particular workstation can be keyed alike at no additional charge if specified when ordering. Keyed Alike means that all locks are identical. To order, specify which products are to be keyed alike and order a "Removable Core Lock Kit" for each group of products to be keyed alike. The specified products will be shipped without lock cores. The cores for each workstation will be packaged separately. All Removable Core Lock Kits are shipped with a control key for removing or inserting lock cores. Note that a control key works only when a lock is in the unlocked position.





Master keys, which operate any removable core lock, are available for \$35 net each.

One control key is provided for each "key alike" order. If additional keys are needed, cost is \$35 net each.

Additional keys can be purchased for \$15 net per key.

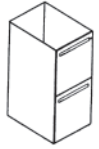
Market Series

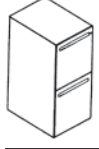
workspace supporting and fixed pedestals w/ proud drawers

DESCRIPTION	ITEM #	D	W	H	PRICE	SHIP WT.	LEAD TIME*
Worksurface Supporting Pedestals file/file, open top 	MK-WP18FF	18"	15"	27 ½"	\$734	85	S
	MK-WP24FF	22"	15"	27 ½"	\$744	85	S
	MK-WP28FF	28"	15"	27 ½"	\$830	85	S
Worksurface Supporting Pedestals box/box/file, open top 	MK-WP18BBF	18"	15"	27 ½"	\$754	88	S
	MK-WP24BBF	22"	15"	27 ½"	\$764	88	S
	MK-WP28BBF	28"	15"	27 ½"	\$850	88	S
Fixed Pedestal file/file 	MK-FP18FF	18"	15"	27 ½"	\$760	87	S
	MK-FP24FF	22"	15"	27 ½"	\$770	87	S
	MK-FP28FF	28"	15"	27 ½"	\$856	87	S
Fixed Pedestal box/box/file 	MK-FP18BBF	18"	15"	27 ½"	\$780	83	S
	MK-FP24BBF	22"	15"	27 ½"	\$790	83	S
	MK-FP28BBF	28"	15"	27 ½"	\$876	83	S

to order

- Item Number
- Pull Style
- Paint Finish

example **MK-WP18FF - FL - 5503**

ITEM NUMBER PULL STYLE PAINT FINISH

please separate each item with a dash



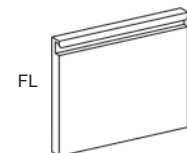

drawer pull options

MODEL	DESCRIPTION
FL	Full



Market Series

mobile pedestals w/ proud drawers

DESCRIPTION	ITEM #	COM	D	W	H	PRICE	SHIP WT.	LEAD TIME*
Mobile Pedestal file/file 	MK-MP18FF		18"	15"	27 ½"	\$860	83	S
	MK-MP24FF		22"	15"	27 ½"	\$890	83	S
	MK-MP28FF		28"	15"	27 ½"	\$990	83	S
Mobile Pedestal box/box/file 	MK-MP18BBF		18"	15"	27 ½"	\$880	87	S
	MK-MP24BBF		22"	15"	27 ½"	\$910	87	S
	MK-MP28BBF		28"	15"	27 ½"	\$1010	87	S
Mobile Pedestal cushion top box/file 	MK-ZFMP18BF	1 YD	18"	15"	24 ½"	\$964	80	S
	MK-ZFMP24BF	1 YD	22"	15"	24 ½"	\$988	80	S
	MK-ZFMP28BF	1 YD	28"	15"	24 ½"	\$1004	80	S
Mobile Pedestal metal top box/file 	MK-ZMP18BF		18"	15"	22 ¾"	\$648	80	S
	MK-ZMP24BF		22"	15"	22 ¾"	\$670	80	S
	MK-ZMP28BF		28"	15"	22 ¾"	\$770	80	S

to order

- Item Number
- Pull Style
- Paint Finish
- Fabric (for cushion top pedestal only)

example **MK-MP18FF - FL - 5503 -**

ITEM NUMBER PULL STYLE PAINT FINISH FABRIC

please separate each item with a dash

drawer pull options

MODEL	DESCRIPTION
FL	Full

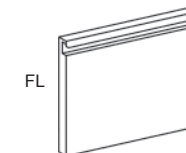

Market Series

introduction - lateral files & storage cabinets



General

Market Lateral Files and Overfile units are 18" deep. Adjustable glides are standard at the front and rear of all cases. Files are designed with safety interlock mechanisms integrated into the suspensions. All standard lateral files with fixed fronts drawers come with a set of hanging folder frames for side-to-side filing. Two dividers can be substituted for side-to-side rails at no charge if specified when ordering. Front-to-back filing bars may be ordered separately for field installation. All drawer fronts are field replaceable.

Suspensions

All Market Lateral Files have heavy duty, fully progressive steel ball bearing suspensions with integrated slide lock system. The integrated slide lock system has the interlock built into the drawer slide to enable a more positive interlock system.

Assembly

All units ship fully assembled. Interior drawer accessories are field-installed only.

Locks

Market Laterals come standard with a removable core lock for easy reconfiguration on site. Units can be keyed alike to other Haskell Products upon request.

Wood Core Tops

Laminate tops are available as a separate component to span multiple files. Tops are available with a 3mm edge. All wood core tops are 1 1/8" thick.

Unit Construction

The Market Series Pedestal and Lateral drawer fronts are external to the case and are referred to as Proud.

Keying Information and Locking Options

All locks feature a removable core which is easily removed on site. All lock cores are interchangeable through all products as cores are universal.

Locks throughout an order or locks within a particular workstation can be keyed alike at no additional charge if specified when ordering. "Keyed Alike" means that all locks are identical. To order, specify which products are to be keyed alike and order a "Removable Core Lock Kit" for each group of products to be keyed alike. The specified products will be shipped without lock cores. The cores for each workstation will be packaged separately. All Removable Core Lock Kits are shipped with a control key for removing or inserting lock cores. Note that a control key works only when a lock is in the unlocked position.

Master keys, which operate any removable core lock, are available for \$35 net each.

One control key is provided for each "key alike" order. If additional keys are needed, cost is \$35 net each.

Additional keys can be purchased for \$15 net per key.

Market Series

lateral files w/ 12" proud drawers

DESCRIPTION	ITEM #	NOTE	D	W	H	PRICE	SHIP WT.	LEAD TIME*
Two High (2) 12" proud drawers	MK-LA12P-3024-2D		18"	30"	27 1/2"	\$1336	103	S
	MK-LA12P-3624-2D		18"	36"	27 1/2"	\$1414	119	S
	MK-LA12P-4224-2D		18"	42"	27 1/2"	\$1492	134	S
Three High (3) 12" proud drawers	MK-LA12P-3036-3D		18"	30"	39 1/2"	\$1798	143	S
	MK-LA12P-3636-3D		18"	36"	39 1/2"	\$1892	162	S
	MK-LA12P-4236-3D		18"	42"	39 1/2"	\$1974	181	S
Four High (4) 12" proud drawers	MK-LA12P-3048-4D		18"	30"W	51 1/2"	\$2176	182	S
	MK-LA12P-3648-4D		18"	36"W	51 1/2"	\$2388	205	S
	MK-LA12P-4248-4D		18"	42"W	51 1/2"	\$2498	227	S
Five High (4) 12" proud drawers & (1) 12" flipper door w/ fixed shelf	MK-LA12P-3060-4D1R	Top drawer rests on top of unit	18"	30"	67 3/8"	\$2680	221	S
	MK-LA12P-3660-4D1R	Top drawer rests on top of unit	18"	36"	67 3/8"	\$2948	248	S
	MK-LA12P-4260-4D1R	Top drawer rests on top of unit	18"	42"	67 3/8"	\$3064	274	S

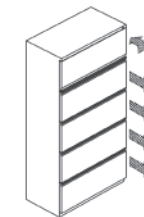

to order

- Item Number
- Pull Style
- Paint Finish

example **MK-LA12P-3024-2D - FL - 5503**

ITEM NUMBER PULL STYLE PAINT FINISH

please separate each item with a dash

drawer pull options

MODEL	DESCRIPTION
FL	Full



Market Series

lateral pedestals w/ proud drawers

DESCRIPTION	ITEM #	NOTE	D	W	H	PRICE	SHIP WT.	LEAD TIME*
Filing Center Pedestal-right combo-unit bottom drawer equipped w/ side-to-side hanging bars, open top	MK-LS12-3024R-2Y	Unit fits under worksurface	18"	30"	27 1/2"	\$2040	90	S
Filing Center Pedestal-left combo-unit bottom drawer equipped w/ side-to-side hanging bars, open top	MK-LS12-3024L-2Y	Unit fits under worksurface	18"	30"	27 1/2"	\$2040	90	S
Lateral File Pedestal file/file, drawers equipped w/ side-to-side hanging bars, open top	MK-LS12-3024-2D	Unit fits under worksurface	18"	30"	27 1/2"	\$1386	103	S
	MK-LS12-3624-2D	Unit fits under worksurface	18"	36"	27 1/2"	\$1448	119	S
	MK-LS12-4224-2D	Unit fits under worksurface	18"	42"	27 1/2"	\$1458	134	S

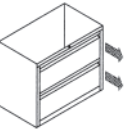
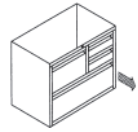
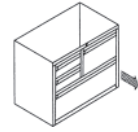

to order

- Item Number
- Pull Style
- Paint Finish

example **MK-LS12-3024R-2Y - FL - 5503**

ITEM NUMBER PULL STYLE PAINT FINISH

please separate each item with a dash

drawer pull options

MODEL DESCRIPTION

FL Full

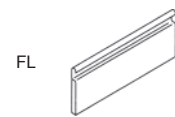

Market Series

wardrobe cabinets

DESCRIPTION	ITEM #	D	W	H	PRICE	SHIP WT.	LEAD TIME*
Wardrobe Unit, 18" D (1) fixed shelf, coat hanger, (2) hooks	MK-CW12-3048-FL	18"	30"	51 1/2"	\$1790	110	S
	MK-CW12-3060-FL	18"	30"	67 3/8"	\$2102	125	S
	MK-CW12-3648-FL	18"	36"	51 1/2"	\$1924	120	S
	MK-CW12-3660-FL	18"	36"	67 3/8"	\$2138	135	S
	MK-CW12-4248-FL	18"	42"	51 1/2"	\$2268	138	S
	MK-CW12-4260-FL	18"	42"	67 3/8"	\$2468	153	S
Wardrobe Unit, 24" D (1) fixed shelf, coat hanger, (2) hooks	MK-CW12-304824-FL	24"	30"	51 1/2"	\$2258	132	S
	MK-CW12-306024-FL	24"	30"	67 3/8"	\$2452	148	S
	MK-CW12-364824-FL	24"	36"	51 1/2"	\$2478	144	S
	MK-CW12-366024-FL	24"	36"	67 3/8"	\$2488	159	S
	MK-CW12-424824-FL	24"	42"	51 1/2"	\$2636	162	S
	MK-CW12-426024-FL	24"	42"	67 3/8"	\$2688	178	S
Wardrobe/Storage Unit, 18" D (2) adjustable shelves, coat hanger, (1) hook	MK-CC12-3048-FL	18"	30"	51 1/2"	\$2268	118	S
	MK-CC12-3060-FL	18"	30"	67 3/8"	\$2558	133	S
	MK-CC12-3648-FL	18"	36"	51 1/2"	\$2288	134	S
	MK-CC12-3660-FL	18"	36"	67 3/8"	\$2588	150	S
	MK-CC12-4248-FL	18"	42"	51 1/2"	\$2798	162	S
	MK-CC12-4260-FL	18"	42"	67 3/8"	\$2878	174	S

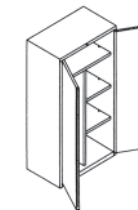
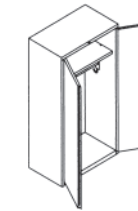
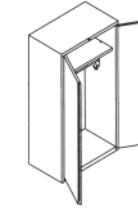

to order

- Item Number
- Paint Finish

example **MK-CW12-3648-FL - 5503**

ITEM NUMBER PAINT FINISH

please separate each item with a dash

drawer pull

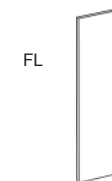

MODEL DESCRIPTION

FL Full

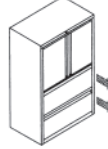

Market Series

combination cabinets w/ proud drawers

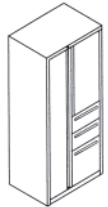
DESCRIPTION	ITEM #	D	W	H	PRICE	SHIP WT.	LEAD TIME*
Lateral/Storage Unit (2) 12" drawers (1) 36" storage cabinet (1) adjustable shelf 	MK-FC12-3660-2D-FL	18"	36"	67 3/8"	\$3024	205	S
Lateral/Storage Unit (3) 12" drawers (1) 24" storage cabinet (1) adjustable shelf 	MK-FC12-3660-3D-FL	18"	36"	67 3/8"	\$3162	248	S
Personal Storage Tower (1) full height wardrobe (1) Box/Box/File pedestal (1) 36" storage cabinet 	MK-TW12-242365-BBF	23"	24"	63 1/2"	\$2988	265	S

to order 1. Item Number
2. Paint Finish

example **MK-FC12-3660-2D-FL - 5503**

ITEM NUMBER PAINT FINISH

please separate each item with a dash

drawer pull

MODEL DESCRIPTION

FL Full

FL 

Market Series

storage cabinets

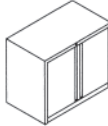
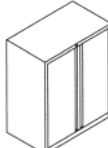
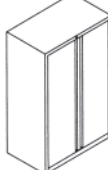
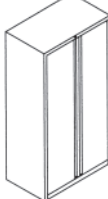
DESCRIPTION	ITEM #	D	W	H	PRICE	SHIP WT.	LEAD TIME*
Storage Cabinet, 27 1/2" H (1) adjustable shelf 	MK-CA12-3024-1A-FL	18"	30"	27 1/2"	\$1224	72	S
	MK-CA12-3624-1A-FL	18"	36"	27 1/2"	\$1266	75	S
	MK-CA12-4224-1A-FL	18"	42"	27 1/2"	\$1366	80	S
	MK-CA12-302424-1A-FL	24"	30"	27 1/2"	\$1632	83	S
	MK-CA12-362424-1A-FL	24"	36"	27 1/2"	\$1688	85	S
	MK-CA12-422424-1A-FL	24"	42"	27 1/2"	\$1824	88	S
Storage Cabinet, 39 1/2" H (2) adjustable shelves 	MK-CA12-3036-2A-FL	18"	30"	39 1/2"	\$1468	91	S
	MK-CA12-3636-2A-FL	18"	36"	39 1/2"	\$1538	100	S
	MK-CA12-4236-2A-FL	18"	42"	39 1/2"	\$1670	105	S
	MK-CA12-302436-2A-FL	24"	30"	39 1/2"	\$2190	104	S
	MK-CA12-362436-2A-FL	24"	36"	39 1/2"	\$2294	111	S
	MK-CA12-422436-2A-FL	24"	42"	39 1/2"	\$2490	118	S
Storage Cabinet, 51 1/2" H (3) adjustable shelves 	MK-CA12-3048-3A-FL	18"	30"	51 1/2"	\$1768	118	S
	MK-CA12-3648-3A-FL	18"	36"	51 1/2"	\$1876	125	S
	MK-CA12-4248-3A-FL	18"	42"	51 1/2"	\$2090	133	S
	MK-CA12-302448-3A-FL	24"	30"	51 1/2"	\$2358	130	S
	MK-CA12-362448-3A-FL	24"	36"	51 1/2"	\$2500	138	S
	MK-CA12-422448-3A-FL	24"	42"	51 1/2"	\$2784	144	S
Storage Cabinet, 67 3/8" H (3) adjustable shelves 	MK-CA12-3060-3A-FL	18"	30"	67 3/8"	\$2140	139	S
	MK-CA12-3660-3A-FL	18"	36"	67 3/8"	\$2282	150	S
	MK-CA12-4260-3A-FL	18"	42"	67 3/8"	\$2496	155	S
	MK-CA12-302460-3A-FL	24"	30"	67 3/8"	\$2850	159	S
	MK-CA12-362460-3A-FL	24"	36"	67 3/8"	\$3040	164	S
	MK-CA12-422460-3A-FL	24"	42"	67 3/8"	\$3328	171	S

to order 1. Item Number
2. Paint Finish

example **MK-CA12-3624-1A-FL - 5503**

ITEM NUMBER PAINT FINISH

please separate each item with a dash

drawer pull



MODEL DESCRIPTION

FL Full

FL 

Market Series

storage cabinets

DESCRIPTION	ITEM #	NOTE	D	W	H	PRICE	SHIP WT.	LEAD TIME*
Single Door Storage Cabinet	MK-SC18R-1864-FL	Door opens to the right	24"	18"	67 3/4"	\$1690	84	S
								
Single Door Storage Cabinet	MK-SC18L-1864-FL	Door opens to the left	24"	18"	67 3/4"	\$1690	84	S
								
Hanger Bar	MK-SC18-HB	For 18" W cabinet				\$130	4	S
Shelf	MK-SC18-SSH	For 18" W cabinet				\$130	4	S

to order

1. Item Number
2. Paint Finish

example **MK-SC18R-1864-FL - 5503**

ITEM NUMBER PAINT FINISH

please separate each item with a dash

drawer pull

MODEL DESCRIPTION

FL Full

FL 

Market Series

overfiles cabinets

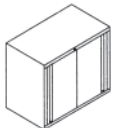
DESCRIPTION	ITEM #	NOTE	D	W	H	PRICE	SHIP WT.	LEAD TIME*
Overfile Cabinet, 27 1/2" H hinged doors	MK-OA12-3025-FL-H	When used in conjunction w/ 3-12" lateral the height will line up w/ a 5-12" lateral case	18"	30"	27 1/2"	\$1016	78	S
								
	MK-OA12-3625-FL-H	When used in conjunction w/ 3-12" lateral the height will line up w/ a 5-12" lateral case	18"	36"	27 1/2"	\$1194	89	S
	MK-OA12-4225-FL-H	When used in conjunction w/ 3-12" lateral the height will line up w/ a 5-12" lateral case	18"	42"	27 1/2"	\$1440	89	S

to order

1. Item Number
2. Paint Finish

example **MK-OA12-3015-FL-H - 5503**

ITEM NUMBER PAINT FINISH

please separate each item with a dash

drawer pull

MODEL DESCRIPTION

FL Full

FL 

Market Series

lateral files laminate tops

DESCRIPTION	ITEM NUMBER	NOTE	D	W	3MM EDGE	SHIP WT.	LEAD TIME*
Laminate Tops	HKLFT1830	For (1) 30" W lateral file	18"	30"	\$208	18	S
	HKLFT1836	For (1) 36" W lateral file	18"	36"	\$240	20	S
	HKLFT1842	For (1) 42" W lateral file	18"	42"	\$270	25	S
	HKLFT1860	For (2) 30" W lateral files	18"	60"	\$340	35	S
	HKLFT1872	For (2) 36" W lateral files	18"	72"	\$410	42	S
	HKLFT1884	For (2) 42" W lateral files	18"	84"	\$470	49	S

to order

- Item Number
- Laminate
- Edge Finish

example **HKLFT1830 - HS - 4072**

ITEM NUMBER LAMINATE EDGE FINISH

please separate each item with a dash

Market Series

lateral files accessories

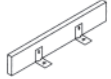
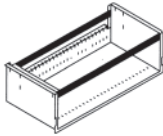
DESCRIPTION	ITEM #	NOTE	PRICE	SHIP WT.	LEAD TIME*
Counter Weight	CWF	For use with any size lateral file	\$248	20	S
					
Proud Hanging Bars front-to-back	FBS/18-2-P	Sold as set, one set required per drawer. For use in any size lateral file	\$88	1	S
Proud Hanging Bars side-to-side	SSS-30-P	For 30" W drawers	\$88	1	S
	SSS-36-P	For 36" W drawers	\$88	1	S
	SSS-42-P	For 42" W drawers	\$88	1	S

to order

- Item Number

example **CWF**

ITEM NUMBER

Market Series

introduction - vertical files



Vertical files shown with recessed pulls. Full pulls only are available.

General

Market Vertical Files are 28" in exterior depth with an interior filing capacity of 26". Market Vertical Files come standard with the safety interlock system integrated within each slide, allowing only one drawer to open at a time. All vertical files are available in 15" (letter) width. Adjustable glides are standard at the front and rear of all cases and all files drawers have been designed to accommodate hanging folders.

Suspensions:

All Market Vertical Files have heavy duty, fully progressive steel ball bearing suspensions with integrated slide lock system.

Assembly

All units ship fully assembled. Interior drawer accessories are field-installed only.

Locks

Market Vertical Files come standard with a removable core lock for easy reconfiguration on site. Units can be keyed alike to other Haskell Products upon request.

Unit Construction

The Market Series Pedestal and Vertical drawer fronts are external to the case and are referred to as Proud.

Wood Core Tops

Laminate tops are available as a separate component to span one to four files. Tops are available with a 3mm edge. All wood core tops are 1 1/8" thick.

Keying Information and Locking Options

All locks feature a removable core which is easily removed on site. All lock cores are interchangeable through all products as cores are universal.

Locks throughout an order or locks within a particular workstation can be keyed alike at no additional charge if specified when ordering. Keyed Alike means that all locks are identical. To order, specify which products are to be keyed alike and order a "Removable Core Lock Kit" for each group of products to be keyed alike. The specified products will be shipped without lock cores. The cores for each workstation will be packaged separately. All Removable Core Lock Kits are shipped with a control key for removing or inserting lock cores. Note that a control key works only when a lock is in the unlocked position.

Master keys, which operate any removable core lock, are available for \$35 net each.

One control key is provided for each "key alike" order. If additional keys are needed, cost is \$35 net each.

Additional keys can be purchased for \$15 net per key.

Market Series

letter width vertical file w/ proud drawers

DESCRIPTION	ITEM #	D	W	H	PRICE	SHIP WT.	LEAD TIME*
Letter Two High	MK-HVFR2	28"	15"	27 1/2"	\$925	72	S
Letter Three High	MK-HVFR3	28"	15"	39 1/2"	\$1320	98	S
Letter Four High	MK-HVFR4	28"	15"	51 1/2"	\$1514	125	S
Letter Five High	MK-HVFR5	28"	15"	63 1/2"	\$2064	148	S

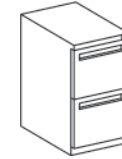

to order

1. Item Number
2. Pull Style
3. Paint Finish

example

MK-HVFR2 - FL - 5503
ITEM NUMBER PULL STYLE PAINT FINISH
 please separate each item with a dash

drawer pull options

MODEL	DESCRIPTION
FL	Full

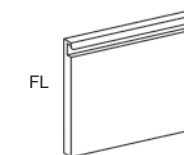

Market Series

vertical files laminate tops

DESCRIPTION	ITEM NUMBER	NOTE	D	W	3MM EDGE	SHIP WT.	LEAD TIME*
Laminate Tops for letter width files	HKVF1428	For (1) letter width file	28"	15"	\$218	12	S
	HKVF2928	For (2) letter width files	28"	30"	\$304	22	S
	HKVF4328	For (3) letter width files	28"	45 7/8"	\$378	32	S
	HKVF5828	For (4) letter width files	28"	60"	\$448	42	S

to order

- Item Number
- Laminate
- Edge Finish

example **HKVF1428 - HS - 4072**

ITEM NUMBER LAMINATE EDGE FINISH

please separate each item with a dash

Market Series

introduction - bookcases



General

All Market Bookcases are 14" in exterior depth and are available in three standard widths 30", 36" and 42". Market Bookcases have 4 height options 27 1/2", 39 1/2", 51 1/2" and 67 1/2". Adjustable glides are standard at the front and rear of all cases.

Shelf Configuration

All Market Bookcases have (1) fixed bottom shelf.

- 27 1/2" high bookcases have (1) adjustable shelf.
- 39 1/2" high bookcases have (2) adjustable shelves.
- 51 1/2" high bookcases have (3) adjustable shelves.
- 67 1/2" high bookcases have (4) adjustable shelves.

Each Adjustable shelf includes 4 clips to position the shelf at customer's preference. Additional shelves are available.

Assembly

All units ship fully assembled.

Installation





Correct installation should include proper leveling and ganging of multiple units.

Wood Core Tops

Laminate tops are available as a separate component. Tops are available with a 3mm edge. All wood core tops are 1 1/8" thick.

Market Series

bookcases

DESCRIPTION	ITEM #	NOTE	D	W	H	PRICE	SHIP WT.	LEAD TIME*
Bookcase, 27 1/2"H (1) adjustable shelf 	MK-BC215-30		14"	30"	27 1/2"	\$748	40	S
	MK-BC215-36		14"	36"	27 1/2"	\$768	46	S
	MK-BC215-42		14"	42"	27 1/2"	\$818	52	S
Bookcase, 39 1/2"H (2) adjustable shelves 	MK-BC315-30		14"	30"	39 1/2"	\$868	58	S
	MK-BC315-36		14"	36"	39 1/2"	\$906	64	S
	MK-BC315-42		14"	42"	39 1/2"	\$948	70	S
Bookcase, 51 1/2"H (3) adjustable shelves 	MK-BC415-30		14"	30"	51 1/2"	\$1062	72	S
	MK-BC415-36		14"	36"	51 1/2"	\$1110	78	S
	MK-BC415-42		14"	42"	51 1/2"	\$1156	84	S
Bookcase, 68"H (4) adjustable shelves 	MK-BC515-30		14"	30"	68"	\$1224	82	S
	MK-BC515-36		14"	36"	68"	\$1272	88	S
	MK-BC515-42		14"	42"	68"	\$1318	94	S
Adjustable Shelves (4) clips 	MK-HFBC3015SH	For 30" W bookcase	14"	30"		\$162	5	
	MK-HFBC3615SH	For 36" W bookcase	14"	36"		\$168	5	
	MK-HFBC4215SH	For 42" W bookcase	14"	42"		\$178	5	

to order

- Item Number
- Paint Finish

example **MK-BC215-30 - 5503**

ITEM NUMBER PAINT FINISH

please separate each item with a dash

Market Series

bookcases laminate tops

DESCRIPTION	ITEM NUMBER	NOTE	D	W	3MM EDGE	SHIP WT.	LEAD TIME*
Laminate Tops for bookcases 	HKBCT1430	For 30" W bookcase	14"	30"	\$276	20	S
	HKBCT1436	For 36" W bookcase	14"	36"	\$304	24	S
	HKBCT1442	For 42" W bookcase	14"	42"	\$338	28	S

to order

- Item Number
- Laminate
- Edge Finish

example **HKBCT1430 - HS - 4072**

ITEM NUMBER LAMINATE EDGE FINISH

please separate each item with a dash

Market Series

introduction - desking



General

All Market Desking Units are 28 3/4" H. All worksurfaces are laminate wood core tops at 1 3/16" thick and are available with a 3mm edge. Pedestals lock individually.

Locks

Market Desks come standard with a removable core lock for easy reconfiguration on site. Units can be keyed alike to other Haskell products upon request.

Installation

Correct installation should include proper leveling.

Application Considerations

When specifying the units for workstation configurations, note the following points:

*24" D returns are used for the 66" x 30" or wider single pedestal desks.

COM

All COM yardage is based on a 54" wide fabric.

Keying Information and Locking Options

All locks feature a removable core which is easily removed on site. All lock cores are interchangeable through all products as cores are universal.

Locks throughout an order or locks within a particular workstation can be keyed alike at no additional charge if specified when ordering. Keyed Alike means that all locks are identical. To order, specify which products are to be keyed alike and order a "Removable Core Lock Kit" for each group of products to be keyed alike. The specified products will be shipped without lock cores. The cores for each workstation will be packaged separately. All Removable Core Lock Kits are shipped with a control key for removing or inserting lock cores. Note that a control key works only when a lock is in the unlocked position.

Master keys, which operate any removable core, lock are available for \$35 net each.

One control key is provided for each "key alike" order. If additional keys are needed, cost is \$35 net each.

Additional keys can be purchased for \$15 net per key.

Market Series

double pedestal desks

DESCRIPTION	ITEM #	D	W	H	3MM EDGE	SHIP WT.	LEAD TIME*
Double Pedestal Desk full height, 28 3/4" D pedestals, locks & center drawer	MK-SDC6030FP-BBF-FF	30"	60"	28 3/4"	\$2794	236	S
	MK-SDC6630FP-BBF-FF	30"	66"	28 3/4"	\$2830	253	S
	MK-SDC7230FP-BBF-FF	30"	72"	28 3/4"	\$2944	265	S
Double Pedestal Desk full height, 28 3/4" D pedestals & locks	MK-SD6030FP-BBF-FF	30"	60"	28 3/4"	\$2514	236	S
	MK-SD6630FP-BBF-FF	30"	66"	28 3/4"	\$2564	253	S
	MK-SD7230FP-BBF-FF	30"	72"	28 3/4"	\$2680	265	S
Double Pedestal Desk full height, 28 3/4" D pedestals, end panels & locks	MK-SD6030EP-BBF-FF-24	30"	60"	28 3/4"	\$3068	231	S
	MK-SD6630EP-BBF-FF-24	30"	66"	28 3/4"	\$3088	251	S
	MK-SD7230EP-BBF-FF-24	30"	72"	28 3/4"	\$3264	263	S

to order

1. Item Number
2. Pull Style
3. Paint Finish
4. Laminate
5. Edge Finish

example MK-SDC6030FP-BBF-FF - 5503 - HS - 4072

ITEM NUMBER PAINT FINISH LAMINATE EDGE FINISH

please separate each item with a dash

drawer pull options

MODEL DESCRIPTION

FL Full

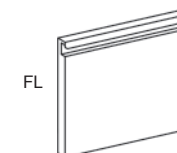

Market Series

bow front double pedestal desks

DESCRIPTION	ITEM #	D	W	H	3MM EDGE	SHIP WT.	LEAD TIME*
Bow Front Double Pedestal Desk full height, 28 3/4" D pedestals, locks & center drawer	MK-SDC6648FP-BOW	48"	66"	28 3/4"	\$3264	273	S
	MK-SDC7248FP-BOW	48"	72"	28 3/4"	\$3564	285	S
Bow Front Double Pedestal Desk full height, 28 3/4" D pedestals & locks	MK-SD6648FP-BOW	48"	66"	28 3/4"	\$3000	273	S
	MK-SD7248FP-BOW	48"	72"	28 3/4"	\$3300	285	S



Market Series

single pedestal desks - right

DESCRIPTION	ITEM #	D	W	H	3MM EDGE	SHIP WT.	LEAD TIME*
Single Right Pedestal Desk full height b/b/f pedestal, locks & center drawer	MK-SSC6024FP-18-BBF	24"	60"	28 3/4"	\$2258	175	S
	MK-SSC6624FP-18-BBF	24"	66"	28 3/4"	\$2298	180	S
	MK-SSC7224FP-18-BBF	24"	72"	28 3/4"	\$2388	195	S
	MK-SSC4830FP-18-BBF	30"	48"	28 3/4"	\$2150	175	S
	MK-SSC6030FP-18-BBF	30"	60"	28 3/4"	\$2344	185	S
	MK-SSC6630FP-18-BBF	30"	66"	28 3/4"	\$2398	210	S
	MK-SSC7230FP-18-BBF	30"	72"	28 3/4"	\$2514	235	S
	MK-SSC7236FP-18-BBF	36"	72"	28 3/4"	\$2564	240	S
Single Right Pedestal Desk full height b/b/f pedestal & locks	MK-SS6024FP-18-BBF	24"	60"	28 3/4"	\$1984	170	S
	MK-SS6624FP-18-BBF	24"	66"	28 3/4"	\$2020	175	S
	MK-SS7224FP-18-BBF	24"	72"	28 3/4"	\$2110	190	S
	MK-SS4830FP-18-BBF	30"	48"	28 3/4"	\$1904	170	S
	MK-SS6030FP-18-BBF	30"	60"	28 3/4"	\$2040	180	S
	MK-SS6630FP-18-BBF	30"	66"	28 3/4"	\$2064	205	S
	MK-SS7230FP-18-BBF	30"	72"	28 3/4"	\$2148	220	S
	MK-SS7236FP-18-BBF	36"	72"	28 3/4"	\$2174	235	S

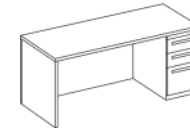

to order

- Item Number
- Pull Style
- Paint Finish
- Laminate
- Edge Finish
- Options

example **MK-SDC6648FP-BOW - FL - 5503 - HS - 4072 - CL**

ITEM NUMBER	PULL STYLE	PAINT FINISH	LAMINATE	EDGE FINISH	OPTIONS
<i>please separate each item with a dash</i>					

drawer pull options		central locking options	
MODEL	DESCRIPTION	MODEL	DESCRIPTION
FL	Full	CL	Central locking is available on desks 66" in width or less
			\$84

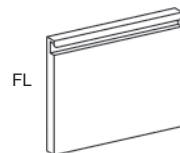

to order

- Item Number
- Pull Style
- Paint Finish
- Laminate
- Edge Finish

example **MK-SSC6024FP-18-BBF - FL - 5503 - HS - 4072**

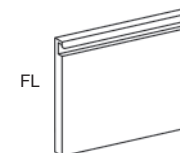

ITEM NUMBER	PULL STYLE	PAINT FINISH	LAMINATE	EDGE FINISH
<i>please separate each item with a dash</i>				

drawer pull options		specification note	
MODEL	DESCRIPTION		
FL	Full	Haskell offers 22 1/4" depth pedestals on 24" depth desks.	
		Haskell offers 28 3/4" depth pedestals on 30" & 36" depth desks.	



Market Series

single pedestal desks - left

DESCRIPTION	ITEM #	D	W	H	3MM EDGE	SHIP WT.	LEAD TIME*
Single Left Pedestal Desk full height b/b/f pedestal, locks & center drawer 	MK-SSC6024FP-12-BBF	24"	60"	28 3/4"	\$2258	175	S
	MK-SSC6624FP-12-BBF	24"	66"	28 3/4"	\$2298	180	S
	MK-SSC7224FP-12-BBF	24"	72"	28 3/4"	\$2388	195	S
	MK-SSC4830FP-12-BBF	30"	48"	28 3/4"	\$2150	175	S
	MK-SSC6030FP-12-BBF	30"	60"	28 3/4"	\$2344	185	S
	MK-SSC6630FP-12-BBF	30"	66"	28 3/4"	\$2398	210	S
	MK-SSC7230FP-12-BBF	30"	72"	28 3/4"	\$2514	235	S
	MK-SSC7236FP-12-BBF	36"	72"	28 3/4"	\$2564	240	S
Single Left Pedestal Desk full height b/b/f pedestal & locks 	MK-SS6024FP-12-BBF	24"	60"	28 3/4"	\$1984	170	S
	MK-SS6624FP-12-BBF	24"	66"	28 3/4"	\$2020	175	S
	MK-SS7224FP-12-BBF	24"	72"	28 3/4"	\$2110	190	S
	MK-SS4830FP-12-BBF	30"	48"	28 3/4"	\$1904	170	S
	MK-SS6030FP-12-BBF	30"	60"	28 3/4"	\$2014	180	S
	MK-SS6630FP-12-BBF	30"	66"	28 3/4"	\$2064	205	S
	MK-SS7230FP-12-BBF	30"	72"	28 3/4"	\$2148	220	S
	MK-SS7236FP-12-BBF	36"	72"	28 3/4"	\$2174	235	S

to order

- Item Number
- Pull Style
- Paint Finish
- Laminate
- Edge Finish

example MK-SSC6024FP-12-BBF - FL - 5503 - HS - 4072

ITEM NUMBER PULL STYLE PAINT FINISH LAMINATE EDGE FINISH

please separate each item with a dash

drawer pull options

MODEL DESCRIPTION
FL Full

specification note
Haskell offers 22 1/4" depth pedestals on 24" depth desks.
Haskell offers 28 3/4" depth pedestals on 30" & 36" depth desks.

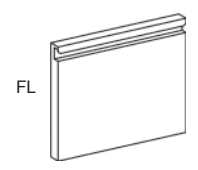

Market Series

desk & return shells

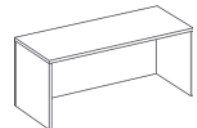
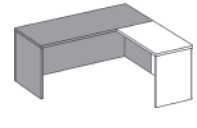
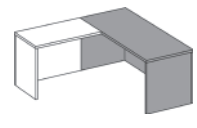
DESCRIPTION	ITEM #	D	W	H	3MM EDGE	SHIP WT.	LEAD TIME*
Desk Shell accommodates right or left return 	MK-DS4824	24"	48"	28 3/4"	\$1294	107	S
	MK-DS6024	24"	60"	28 3/4"	\$1404	121	S
	MK-DS6624	24"	66"	28 3/4"	\$1434	129	S
	MK-DS7224	24"	72"	28 3/4"	\$1464	149	S
	MK-DS4830	30"	48"	28 3/4"	\$1358	118	S
	MK-DS6030	30"	60"	28 3/4"	\$1538	133	S
	MK-DS6630	30"	66"	28 3/4"	\$1574	144	S
	MK-DS7230	30"	72"	28 3/4"	\$1634	154	S
	MK-DS7236	36"	72"	28 3/4"	\$1658	165	S
Return Shell - right 	MK-SR3618-18	18"	36"	28 3/4"	\$884	58	S
	MK-SR4218-18	18"	42"	28 3/4"	\$904	64	S
	MK-SR4818-18	18"	48"	28 3/4"	\$924	68	S
	MK-SR6018-18	18"	60"	28 3/4"	\$944	78	S
	MK-SR3624-18	24"	36"	28 3/4"	\$958	71	S
	MK-SR4224-18	24"	42"	28 3/4"	\$974	71	S
	MK-SR4824-18	24"	48"	28 3/4"	\$998	77	S
	MK-SR6024-18	24"	60"	28 3/4"	\$1054	88	S
	Return Shell - left 	MK-SR3618-12	18"	36"	28 3/4"	\$884	58
MK-SR4218-12		18"	42"	28 3/4"	\$904	64	S
MK-SR4818-12		18"	48"	28 3/4"	\$924	68	S
MK-SR6018-12		18"	60"	28 3/4"	\$944	78	S
MK-SR3624-12		24"	36"	28 3/4"	\$958	71	S
MK-SR4224-12		24"	42"	28 3/4"	\$974	71	S
MK-SR4824-12		24"	48"	28 3/4"	\$998	77	S
MK-SR6024-12		24"	60"	28 3/4"	\$1054	88	S

to order

- Item Number
- Pull Style
- Paint Finish
- Laminate
- Edge Finish

example MK-DS4824 - FL - 5503 - HS - 4072

ITEM NUMBER PULL STYLE PAINT FINISH LAMINATE EDGE FINISH

please separate each item with a dash

drawer pull options

MODEL DESCRIPTION
FL Full

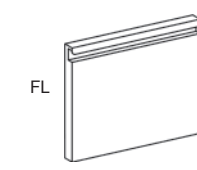

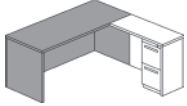
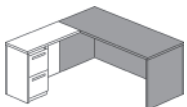

Market Series

pedestal returns

DESCRIPTION	ITEM #	D	W	H	3MM EDGE	SHIP WT.	LEAD TIME*
Right Pedestal Return full height, 22¼" D fff pedestal 	MK-SPR3624FP-18-FF	24"	36"	28 ¾"	\$1350	120	S
	MK-SPR4224FP-18-FF	24"	42"	28 ¾"	\$1358	126	S
	MK-SPR4824FP-18-FF	24"	48"	28 ¾"	\$1448	132	S
	MK-SPR6024FP-18-FF	24"	60"	28 ¾"	\$1520	140	S
Left Pedestal Return full height, 22¼" D fff pedestal 	MK-SPR3624FP-12-FF	24"	36"	28 ¾"	\$1350	120	S
	MK-SPR4224FP-12-FF	24"	42"	28 ¾"	\$1350	126	S
	MK-SPR4824FP-12-FF	24"	48"	28 ¾"	\$1448	132	S
	MK-SPR6024FP-12-FF	24"	60"	28 ¾"	\$1520	140	S

Market Series

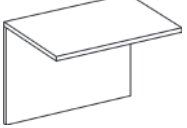
bridge, credenza, corner units

DESCRIPTION	ITEM #	D	W	H	3MM EDGE	SHIP WT.	LEAD TIME*
Bridge for use between two desks 	MK-SUB3624R	24"	36"	28 ¾"	\$718	58	S
	MK-SUB4224R	24"	42"	28 ¾"	\$738	62	S
	MK-SUB4824R	24"	48"	28 ¾"	\$788	70	S
Kneespace Credenza full height, 22¼" D fff pedestal 	MK-SCK6024-FP	24"	60"	28 ¾"	\$2334	230	S
	MK-SCK6624-FP	24"	66"	28 ¾"	\$2398	240	S
	MK-SCK7224-FP	24"	72"	28 ¾"	\$2478	250	S

to order

- Item Number
- Pull Style
- Paint Finish
- Laminate
- Edge Finish

example MK-SPR3624FP-18-FF - FL - 5503 - HS - 4072

ITEM NUMBER PULL STYLE PAINT FINISH LAMINATE EDGE FINISH

please separate each item with a dash

drawer pull options

MODEL DESCRIPTION

FL Full

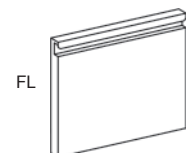

to order

- Item Number
- Pull Style
- Paint Finish
- Laminate
- Edge Finish

example MK-SUB3624R - FL - 5503 - HS - 4072

ITEM NUMBER PULL STYLE PAINT FINISH LAMINATE EDGE FINISH

please separate each item with a dash

drawer pull options

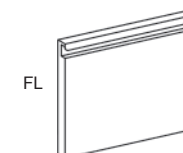

MODEL DESCRIPTION

FL Full



Market Series

D-shape conferencing desk & peninsula

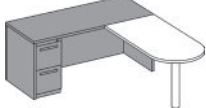
DESCRIPTION	ITEM #	D	W	H	3MM EDGE	SHIP WT.	LEAD TIME*
 D-Shape Conferencing Desk for use with bridge units	MK-SCD6030	30"	60"	28 ¾"	\$1404	102	S
	MK-SCD6630	30"	66"	28 ¾"	\$1448	108	S
	MK-SCD7230	30"	72"	28 ¾"	\$1498	114	S
 P-Shape Conferencing Desk for use with bridge units	MK-SCP7242	42"	72"	28 ¾"	\$1768	125	S
 D-Shape Conferencing Return for use w/ 72", 66" or 60" single ped desks	MK-SCR6030	30"	60"	28 ¾"	\$900	66	S
	MK-SCR6630	30"	66"	28 ¾"	\$948	71	S
	MK-SCR7230	30"	72"	28 ¾"	\$990	77	S

to order

- Item Number
- Pull Style
- Paint Finish
- Laminate
- Edge Finish

example **MK-SCD6030 - FL - 5503 - HS - 4072**

ITEM NUMBER PULL STYLE PAINT FINISH LAMINATE EDGE FINISH

please separate each item with a dash

drawer pull options

MODEL DESCRIPTION

FL Full

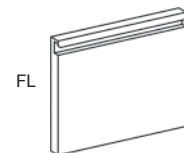

Market Series

overstorage units and tackboards

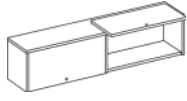
DESCRIPTION	ITEM #	NOTE	COM	D	W	H	PRICE	SHIP WT.	LEAD TIME*
 Wall Mounted Overstorage Cabinet w/ doors that stow on unit top	MK-WM30	Includes mounting hardware		14"	30"	15 ½"	\$962	56	S
	MK-WM36	Includes mounting hardware		14"	36"	15 ½"	\$988	61	S
	MK-WM42	Includes mounting hardware		14"	42"	15 ½"	\$1000	66	S
	MK-WM48	Includes mounting hardware		14"	48"	15 ½"	\$1012	70	S
	MK-WM60	Includes mounting hardware		14"	60"	15 ½"	\$1484	89	S
	MK-WM66**	Includes mounting hardware		14"	66"	15 ½"	\$1950	96	S
Wall Mounted Tackboards for overstorage cabinet	MK-WM72**	Includes mounting hardware		14"	72"	15 ½"	\$1976	103	S
	MK-SFT3019	Includes mounting hardware	2 YD	1"	30"	22 ½"	\$810	28	S
	MK-SFT3619	Includes mounting hardware	2 YD	1"	36"	22 ½"	\$832	38	S
	MK-SFT4219	Includes mounting hardware	2 YD	1"	42"	22 ½"	\$844	42	S
	MK-SFT4819	Includes mounting hardware	2 YD	1"	48"	22 ½"	\$858	48	S
	MK-SFT6019	Includes mounting hardware	2 YD	1"	60"	22 ½"	\$938	68	S
	MK-SFT6619	Includes mounting hardware	2 YD	1"	66"	22 ½"	\$958	74	S
MK-SFT7219	Includes mounting hardware	2.5 YD	1"	72"	22 ½"	\$992	80	S	

to order

- Item Number
- Paint Finish
- Fabric (for tackboards only)

example **MK-SFT3019 - 5503 -**

ITEM NUMBER PAINT FINISH FABRIC/COM



please separate each item with a dash

**MK-WM66 ships as (1) 30" w and (1) 36" w units

**MK-WM72 ships as (2) 36" w units

Market Series

desking accessories

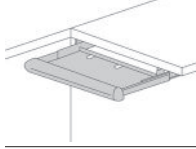
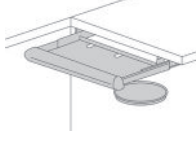
DESCRIPTION	ITEM #	NOTE	PRICE	SHIP WT.	LEAD TIME*
Keyboard Arm 	KB1	Swivels 360 degrees, tils w/ 6" height adjustments Includes wrist rest	\$428	10	S
Keyboard Arm w/ mouse pad 	KB2	Swivels 360 degrees, tils w/ 6" height adjustments Includes wrist rest & mouse pad, for use on left or right	\$484	12	S
Keyboard Tray 	KD1	Steel platform w/ cushion palm rest Steel ball bearing slides	\$634	9	S
Keyboard Tray w/ mouse pad 	KD2	Steel platform w/ cushion palm rest Steel ball bearing slides & mouse pad for use on left or right	\$368	10	S
Box Drawer Divider	HABDD		\$66	4	S
Pedestal Side-to-Side File Bar	HASFB		\$62	4	S
Pencil Tray	MAP1	Black Only	\$62	1	S
24" W Task Light	MTL24		\$248	5.5	S
48" W Task Light	MTL48		\$274	7	S
Center Drawer	CD27	23" D, Specify finish	\$336	5	S

to order 1. Item Number **KB1** example ITEM NUMBER

Market Series

introduction - instruction zone

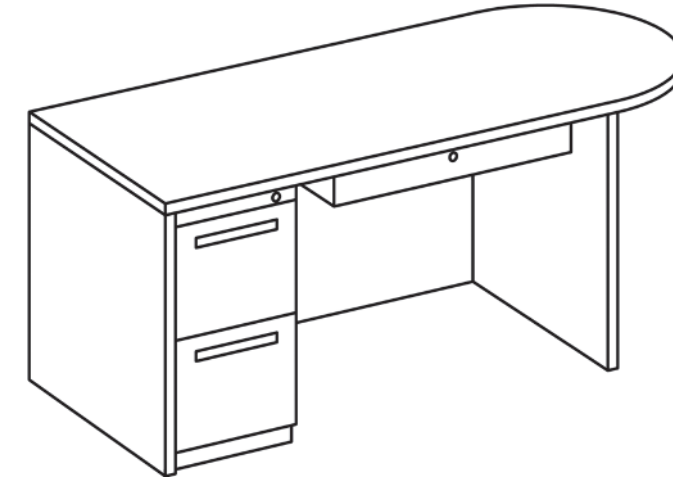

General

All Market Series Desking Units are 28 3/4" H. All worksurfaces are laminate wood core tops at 1 3/16" thick and are available with a 3mm edge. Pedestals lock individually.

Locks

Market Desks come standard with a removable core lock for easy reconfiguration on site. Units can be keyed alike to other Haskell products upon request.

Keying Information and Locking Options

All locks feature a removable core which is easily removed on site. All lock cores are interchangeable through all products as cores are universal.

Locks throughout an order or locks within a particular workstation can be keyed alike at no additional charge if specified when ordering. Keyed Alike means that all locks are identical. To order, specify which products are to be keyed alike and order a "Removable Core Lock Kit" for each group of products to be keyed alike. The specified products will be shipped without lock cores. The cores for each workstation will be packaged separately. All Removable Core Lock Kits are shipped with a control key for removing or inserting lock cores. Note that a control key works only when a lock is in the unlocked position.

Master keys, which operate any removable core, lock are available for \$35 net each.

One control key is provided for each "key alike" order. If additional keys are needed, cost is \$35 net each.

Additional keys can be purchased for \$15 net per key.

Market Series

D-shape educator desk - left

DESCRIPTION	ITEM #	D	W	H	3MM EDGE	SHIP WT.	LEAD TIME*
D-Shape Educators Desk 28 3/4" D f/f pedestal, locks & center drawer	MK-SED6630FL-FF	30"	66"	28 3/4"	\$2424	180	S
	MK-SED7230FL-FF	30"	72"	28 3/4"	\$2508	190	S
D-Shape Educators Desk 28 3/4" D b/b/f pedestal, locks & center drawer	MK-SED6630BL-BBF	30"	66"	28 3/4"	\$2424	180	S
	MK-SED7230BL-BBF	30"	72"	28 3/4"	\$2588	190	S



to order

- Item Number
- Pull Style
- Paint Finish
- Laminate
- Edge Finish

example MK-SED6630FL-FF - FL - 5503 - HS - 4072

ITEM NUMBER PULL STYLE PAINT FINISH LAMINATE EDGE FINISH

please separate each item with a dash

drawer pull options

MODEL	DESCRIPTION
FL	Full

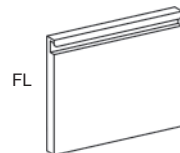

Smart Series

introduction - desking



General

All Smart Desking Units are 29 1/16" H. All worksurfaces are laminate wood core tops at 1 3/16" thick and are available with a 3mm edge. Select Smart Desks are available with locking central drawers and will be noted in product descriptions. Pedestals lock individually. Overstorage units are constructed with a single wall steel back panel with a fabric tackboard insert on front. Overstorage units are available with flipper doors or open shelves.

Locks

Smart Desks come standard with a removable core lock for easy reconfiguration on site. Units can be keyed alike to other Haskell products upon request. Central locking is available on desks 66" in width or less.

Installation

Correct installation should include proper leveling.

Application Considerations

When specifying the units for workstation configurations, note the following points:

*24" D returns are used for the 66" x 30" or wider single pedestal desks.

*Overstorage Units can not be used on 36" D with overhangs. The 6" overhang is not suitable to support a loaded overstorage unit.

COM

All COM yardage is based on a 54" wide fabric.

Keying Information and Locking Options

All locks feature a removable core which is easily removed on site. All lock cores are interchangeable through all products as cores are universal.

Locks throughout an order or locks within a particular workstation can be keyed alike at no additional charge if specified when ordering. Keyed Alike means that all locks are identical. To order, specify which products are to be keyed alike and order a "Removable Core Lock Kit" for each group of products to be keyed alike. The specified products will be shipped without lock cores. The cores for each workstation will be packaged separately. All Removable Core Lock Kits are shipped with a control key for removing or inserting lock cores. Note that a control key works only when a lock is in the unlocked position.

Master keys, which operate any removable core, lock are available for \$35 net each.

One control key is provided for each "key alike" order. If additional keys are needed, cost is \$35 net each.

Additional keys can be purchased for \$15 net per key.

Smart Series

double pedestal desks

DESCRIPTION	ITEM #	D	W	H	3MM EDGE	SHIP WT.	LEAD TIME*
Double Pedestal Desk full height, 28¼" D pedestals, locks & center drawer	SDC6030FP-BBF-FF	30"	60"	29"	\$2720	236	E
	SDC6630FP-BBF-FF	30"	66"	29"	\$2768	253	E
	SDC7230FP-BBF-FF	30"	72"	29"	\$2820	265	E



Double Pedestal Desk full height, 28¼" D pedestals & locks	SD6030FP-BBF-FF	30"	60"	29"	\$2560	236	E
	SD6630FP-BBF-FF	30"	66"	29"	\$2600	253	E
	SD7230FP-BBF-FF	30"	72"	29"	\$2640	265	E



Double Pedestal Desk full height, 28¼" D pedestals, end panels & locks	SD6030EP-BBF-FF-24	30"	60"	29"	\$2816	231	E
	SD6630EP-BBF-FF-24	30"	66"	29"	\$2864	251	E
	SD7230EP-BBF-FF-24	30"	72"	29"	\$3098	263	E



to order

- Item Number
- Pull Style
- Paint Finish
- Laminate
- Edge Finish
- Options

example SDC6030EP-BF - FL - 5503 - HS - 4072 - CL

ITEM NUMBER	PULL STYLE	PAINT FINISH	LAMINATE	EDGE FINISH	OPTIONS
SDC6030EP-BF	FL	5503	HS	4072	CL

please separate each item with a dash

drawer pull options

MODEL	DESCRIPTION
FL	Full

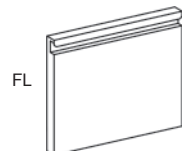

FL

Smart Series

bow front double pedestal desks

DESCRIPTION	ITEM #	D	W	H	3MM EDGE	SHIP WT.	LEAD TIME*
Bow Front Double Pedestal Desk full height, 28¼" D pedestals, locks & center drawer	SDC6648FP-BOW	48"	66"	29"	\$3182	273	E
	SDC7248FP-BOW	48"	72"	29"	\$3476	285	E



Bow Front Double Pedestal Desk full height, 28¼" D pedestals & locks	SD6648FP-BOW	48"	66"	29"	\$2924	273	E
	SD7248FP-BOW	48"	72"	29"	\$3218	285	E



to order

- Item Number
- Pull Style
- Paint Finish
- Laminate
- Edge Finish
- Options

example SDC6648FP-BOW - FL - 5503 - HS - 4072 - CL

ITEM NUMBER	PULL STYLE	PAINT FINISH	LAMINATE	EDGE FINISH	OPTIONS
SDC6648FP-BOW	FL	5503	HS	4072	CL

please separate each item with a dash

drawer pull options

MODEL	DESCRIPTION
FL	Full

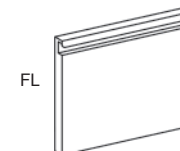

FL

central locking options

MODEL	DESCRIPTION	PRICE
CL	Central locking is available on desks 66" in width or less	\$132

Smart Series

single pedestal desks - right

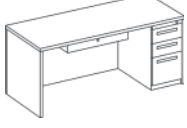
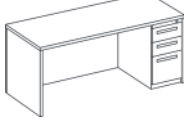
DESCRIPTION	ITEM #	D	W	H	3MM EDGE	SHIP WT.	LEAD TIME*
 Single Right Pedestal Desk, locks & center drawer	SSC6024FP-18-BBF	24"	60"	29"	\$2294	175	E
	SSC6624FP-18-BBF	24"	66"	29"	\$2342	180	E
	SSC7224FP-18-BBF	24"	72"	29"	\$2384	195	E
	SSC4830FP-18-BBF	30"	48"	29"	\$2310	175	E
	SSC6030FP-18-BBF	30"	60"	29"	\$2358	185	E
	SSC6630FP-18-BBF	30"	66"	29"	\$2406	210	E
	SSC7230FP-18-BBF	30"	72"	29"	\$2458	235	E
	SSC7236FP-18-BBF	36"	72"	29"	\$2508	240	E
 Single Right Pedestal Desk & locks	SS6024FP-18-BBF	24"	60"	29"	\$2134	170	E
	SS6624FP-18-BBF	24"	66"	29"	\$2182	175	E
	SS7224FP-18-BBF	24"	72"	29"	\$2224	190	E
	SS4830FP-18-BBF	30"	48"	29"	\$2150	170	E
	SS6030FP-18-BBF	30"	60"	29"	\$2182	180	E
	SS6630FP-18-BBF	30"	66"	29"	\$2246	205	E
	SS7230FP-18-BBF	30"	72"	29"	\$2298	220	E
	SS7236FP-18-BBF	36"	72"	29"	\$2348	235	E

to order

- Item Number
- Pull Style
- Paint Finish
- Laminate
- Edge Finish

example **SSC4830R - FL - 5503 - HS - 4072**

ITEM NUMBER PULL STYLE PAINT FINISH LAMINATE EDGE FINISH

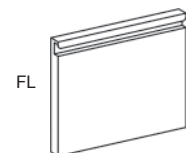

please separate each item with a dash

drawer pull options	specification note
MODEL DESCRIPTION FL Full	Haskell offers 22¼" depth pedestals on 24" depth desks. Haskell offers 28¼" depth pedestals on 30" & 36" depth desks.



Smart Series

single pedestal desks - left

DESCRIPTION	ITEM #	D	W	H	3MM EDGE	SHIP WT.	LEAD TIME*
 Single Left Pedestal Desk, locks & center drawer	SSC6024FP-12-BBF	24"	60"	29"	\$2294	175	E
	SSC6624FP-12-BBF	24"	66"	29"	\$2342	180	E
	SSC7224FP-12-BBF	24"	72"	29"	\$2384	195	E
	SSC4830FP-12-BBF	30"	48"	29"	\$2310	175	E
	SSC6030FP-12-BBF	30"	60"	29"	\$2358	185	E
	SSC6630FP-12-BBF	30"	66"	29"	\$2406	210	E
	SSC7230FP-12-BBF	30"	72"	29"	\$2458	235	E
	SSC7236FP-12-BBF	36"	72"	29"	\$2508	240	E
 Single Left Pedestal Desk & locks	SS6024FP-12-BBF	24"	60"	29"	\$2134	170	E
	SS6624FP-12-BBF	24"	66"	29"	\$2182	175	E
	SS7224FP-12-BBF	24"	72"	29"	\$2224	190	E
	SS4830FP-12-BBF	30"	48"	29"	\$2150	170	E
	SS6030FP-12-BBF	30"	60"	29"	\$2182	180	E
	SS6630FP-12-BBF	30"	66"	29"	\$2246	205	E
	SS7230FP-12-BBF	30"	72"	29"	\$2298	220	E
	SS7236FP-12-BBF	36"	72"	29"	\$2348	235	E

to order

- Item Number
- Pull Style
- Paint Finish
- Laminate
- Edge Finish

example **SSC4830L - FL - 5503 - HS - 4072**

ITEM NUMBER PULL STYLE PAINT FINISH LAMINATE EDGE FINISH

please separate each item with a dash

drawer pull options	specification note
MODEL DESCRIPTION FL Full	Haskell offers 22¼" depth pedestals on 24" depth desks. Haskell offers 28¼" depth pedestals on 30" & 36" depth desks.

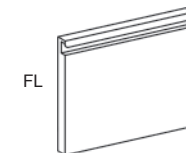

Smart Series

desk & return shells

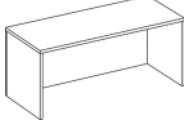
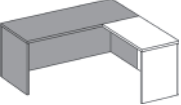
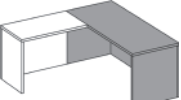
DESCRIPTION	ITEM #	D	W	H	3MM EDGE	SHIP WT.	LEAD TIME*
Desk Shell accommodates right or left return 	DS4824	24"	48"	29"	\$1348	107	E
	DS6024	24"	60"	29"	\$1368	121	E
	DS6624	24"	66"	29"	\$1378	129	E
	DS7224	24"	72"	29"	\$1388	149	E
	DS4830	30"	48"	29"	\$1368	118	E
	DS6030	30"	60"	29"	\$1408	133	E
	DS6630	30"	66"	29"	\$1438	144	E
	DS7230	30"	72"	29"	\$1478	154	E
	DS7236	36"	72"	29"	\$1588	165	E
	Return Shell - right 	SR3624-18	24"	36"	29"	\$1018	71
SR4224-18		24"	42"	29"	\$1032	71	E
SR4824-18		24"	48"	29"	\$1068	77	E
SR6024-18		24"	60"	29"	\$1088	88	E
Return Shell - left 	SR3624-12	24"	36"	29"	\$1018	71	E
	SR4224-12	24"	42"	29"	\$1032	71	E
	SR4824-12	24"	48"	29"	\$1068	77	E
	SR6024-12	24"	60"	29"	\$1088	88	E

to order

- Item Number
- Pull Style
- Paint Finish
- Laminate
- Edge Finish

example **DS4824 - FL - 5503 - HS - 4072**

ITEM NUMBER PULL STYLE PAINT FINISH LAMINATE EDGE FINISH

please separate each item with a dash

drawer pull options

MODEL	DESCRIPTION
FL	Full

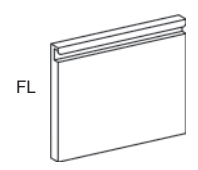

Smart Series

pedestal returns

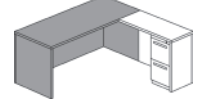
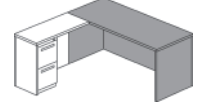
DESCRIPTION	ITEM #	D	W	H	3MM EDGE	SHIP WT.	LEAD TIME*
Right Pedestal Return full height, 22 1/4" D f/f pedestal 	SPR3624FP-18-FF	24"	36"	29"	\$1490	120	E
	SPR4224FP-18-FF	24"	42"	29"	\$1500	126	E
	SPR4824FP-18-FF	24"	48"	29"	\$1638	132	E
	SPR6024FP-18-FF	24"	60"	29"	\$1678	140	E
Left Pedestal Return full height, 22 1/4" D f/f pedestal 	SPR3624FP-12-FF	24"	36"	29"	\$1490	120	E
	SPR4224FP-12-FF	24"	42"	29"	\$1500	126	E
	SPR4824FP-12-FF	24"	48"	29"	\$1638	132	E
	SPR6024FP-12-FF	24"	60"	29"	\$1678	140	E

to order

- Item Number
- Pull Style
- Paint Finish
- Laminate
- Edge Finish

example **SPR4824FP-18-FF - FL - 5503 - HS - 4072**

ITEM NUMBER PULL STYLE PAINT FINISH LAMINATE EDGE FINISH

please separate each item with a dash

drawer pull options

MODEL	DESCRIPTION
FL	Full

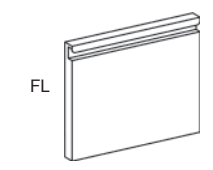

Smart Series

bridge, credenza

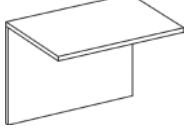
DESCRIPTION	ITEM #	D	W	H	3MM EDGE	SHIP WT.	LEAD TIME*
Bridge for use between two desks 	SUB3624R	24"	36"	29"	\$814	58	E
	SUB4224R	24"	42"	29"	\$834	62	E
	SUB4824R	24"	48"	29"	\$856	70	E

Kneespace Credenza full height, 22 1/4" D fff pedestals 	SCK6024-FP	24"	60"	29"	\$2558	230	E
	SCK6624-FP	24"	66"	29"	\$2606	240	E
	SCK7224-FP	24"	72"	29"	\$2654	250	E

to order

- Item Number
- Pull Style
- Paint Finish
- Laminate
- Edge Finish

example SUB3624R - FL - 5503 - HS - 4072

ITEM NUMBER PULL STYLE PAINT FINISH LAMINATE EDGE FINISH

please separate each item with a dash

drawer pull options

MODEL	DESCRIPTION
FL	Full

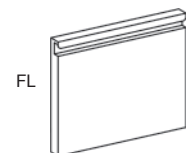

Smart Series

D-shape conferencing desk & peninsula

DESCRIPTION	ITEM #	D	W	H	3MM EDGE	SHIP WT.	LEAD TIME*
D-Shape Conferencing Desk for use with bridge units 	SCD6030	30"	60"	29"	\$1404	102	E
	SCD6630	30"	66"	29"	\$1448	108	E
	SCD7230	30"	72"	29"	\$1498	114	E

P-Shape Conferencing Desk for use with bridge units 	SCP7242	42"	72"	29"	\$1768	125	E
---	---------	-----	-----	-----	--------	-----	---

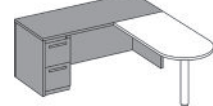
D-Shape Conferencing Return for use w/ 72", 66" or 60" single ped desks 	SCR6030	30"	60"	29"	\$900	66	E
	SCR6630	30"	66"	29"	\$948	71	E
	SCR7230	30"	72"	29"	\$990	77	E

to order

- Item Number
- Pull Style
- Paint Finish
- Laminate
- Edge Finish

example SCP6030 - FL - 5503 - HS - 4072

ITEM NUMBER PULL STYLE PAINT FINISH LAMINATE EDGE FINISH

please separate each item with a dash

drawer pull options

MODEL	DESCRIPTION
FL	Full

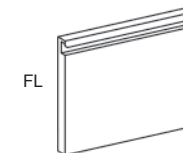

Smart Series

overstorage units and tackboards

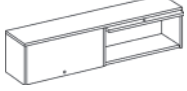
DESCRIPTION	ITEM #	NOTE	COM	D	W	H	PRICE	SHIP WT.	LEAD TIME*
Wall Mounted Overstorage Cabinet 	WM30	Includes mounting hardware		14"	30"	15 1/2"	\$962	56	E
	WM36	Includes mounting hardware		14"	36"	15 1/2"	\$988	61	E
	WM42	Includes mounting hardware		14"	42"	15 1/2"	\$1000	66	E
	WM48	Includes mounting hardware		14"	48"	15 1/2"	\$1012	70	E
	WM60	Includes mounting hardware		14"	60"	15 1/2"	\$1484	89	E
	WM66**	Includes mounting hardware		14"	66"	15 1/2"	\$1950	96	E
	WM72**	Includes mounting hardware		14"	72"	15 1/2"	\$1976	103	E
Wall Mounted Tackboards for overstorage cabinet	SFT3019	Includes mounting hardware	2 YD	1"	30"	22 1/2"	\$810	28	E
	SFT3619	Includes mounting hardware	2 YD	1"	36"	22 1/2"	\$832	38	E
	SFT4219	Includes mounting hardware	2 YD	1"	42"	22 1/2"	\$844	42	E
	SFT4819	Includes mounting hardware	2 YD	1"	48"	22 1/2"	\$858	48	E
	SFT6019	Includes mounting hardware	2 YD	1"	60"	22 1/2"	\$938	68	E
	SFT6619	Includes mounting hardware	2 YD	1"	66"	22 1/2"	\$958	74	E
	SFT7219	Includes mounting hardware	2.5 YD	1"	72"	22 1/2"	\$992	80	E

to order

1. Item Number
2. Paint Finish
3. Fabric (for tackboards only)

example **SOS3619TB - 5503 -**



ITEM NUMBER PAINT FINISH FABRIC/COM

please separate each item with a dash

**WM66 ships as (1) 30" w and (1) 36" w units
 **WM72 ships as (2) 36" w units

Smart Series

desking accessories

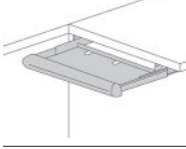
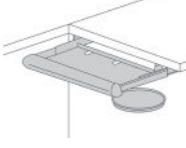
DESCRIPTION	ITEM #	NOTE	PRICE	SHIP WT.	LEAD TIME*
Keyboard Arm 	KB1	Swivels 360 degrees, tils w/ 6" height adjustments Includes wrist rest	\$428	10	S
Keyboard Arm w/ mouse pad 	KB2	Swivels 360 degrees, tils w/ 6" height adjustments Includes wrist rest & mouse pad, for use on left or right	\$484	12	S
Keyboard Tray 	KD1	Steel platform w/ cushion palm rest Steel ball bearing slides	\$634	9	S
Keyboard Tray w/ mouse pad 	KD2	Steel platform w/ cushion palm rest Steel ball bearing slides & mouse pad for use on left or right	\$368	10	S
Box Drawer Divider	HABDD		\$66	4	S
Pedestal Side-to-Side File Bar	HASFB		\$62	4	S
Pencil Tray	MAP1	Black Only	\$62	1	S
24" W Task Light	MTL24		\$248	5.5	S
48" W Task Light	MTL48		\$274	7	S
Center Drawer	CD27	23" D, Specify finish	\$336	5	S

to order

1. Item Number

example **KB1**

ITEM NUMBER

* S – Standard Lead Time 4-6 weeks | E – Extended Lead Time 10-12 weeks | Lead times subject to change without notice

Smart Series

introduction - instruction zone

General

All Smart Desking Units are 29 1/16" H. All worksurfaces are laminate wood core tops at 1 3/16" thick and are available with a 3mm edge. Select Smart Desks are available with locking central drawers and will be noted in product descriptions. Pedestals lock individually. Overstorage units are constructed with a single wall steel back panel with a fabric tackboard insert on front. Overstorage units are available with flipper doors or open shelves.

Locks

Smart Desks come standard with a removable core lock for easy reconfiguration on site. Units can be keyed alike to other Haskell products upon request. Central locking is available on desks 66" in width or less.

Installation

Correct installation should include proper leveling.

Application Considerations

When specifying the units for workstation configurations, note the following points:

*24" D returns are used for the 66" x 30" or wider single pedestal desks.

*Overstorage Units can not be used on 36" D with overhangs. The 6" overhang is not suitable to support a loaded overstorage unit.

COM

All COM yardage is based on a 54" wide fabric.

Keying Information and Locking Options

All locks feature a removable core which is easily removed on site. All lock cores are interchangeable through all products as cores are universal.

Locks throughout an order or locks within a particular workstation can be keyed alike at no additional charge if specified when ordering. Keyed Alike means that all locks are identical. To order, specify which products are to be keyed alike and order a "Removable Core Lock Kit" for each group of products to be keyed alike. The specified products will be shipped without lock cores. The cores for each workstation will be packaged separately. All Removable Core Lock Kits are shipped with a control key for removing or inserting lock cores. Note that a control key works only when a lock is in the unlocked position.





Master keys, which operate any removable core, lock are available for \$35 net each.

One control key is provided for each "key alike" order. If additional keys are needed, cost is \$35 net each.

Additional keys can be purchased for \$15 net per key.

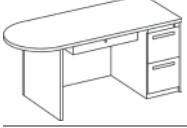
Smart Series

D-shape educator desk - right

DESCRIPTION	ITEM #	D	W	H	3MM EDGE	SHIP WT.	LEAD TIME*
D-Shape Educators Desk 28 1/4" D f/f pedestal, locks & center drawer	SEDC6630FR-FF SEDC7230FR-FF	30"	66"	29"	\$2424	180	E
							
D-Shape Educators Desk 28 1/4" D b/b/f pedestal, locks & center drawer	SEDC6630BR-BBF SEDC7230BR-BBF	30"	66"	29"	\$2458	180	E
							
D-Shape Educators Desk 28 1/4" D f/f pedestal, bookcase, locks & center drawer	SEDC7230FCR-FF	30"	72"	29"	\$3412	260	E
							
D-Shape Educators Desk 28 1/4" D b/b/f pedestal, bookcase, locks & center drawer	SEDC7230BCR-BBF	30"	72"	29"	\$3552	260	E
							

to order

1. Item Number
2. Pull Style
3. Paint Finish
4. Laminate
5. Edge Finish

example

SEDC6630FR-FF - FL - 5503 - HS - 4072
ITEM NUMBER PULL STYLE PAINT FINISH LAMINATE EDGE FINISH
please separate each item with a dash

drawer pull options

MODEL	DESCRIPTION
FL	Full

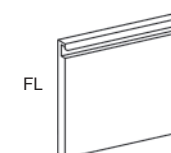

Smart Series

D-shape educator desk - left

DESCRIPTION	ITEM #	D	W	H	3MM EDGE	SHIP WT.	LEAD TIME*
D-Shape Educators Desk 28 1/4" D f/f pedestal, locks & center drawer	SED6630FL-FF	30"	66"	29"	\$2424	180	E
	SED7230FL-FF	30"	72"	29"	\$2508	190	E
D-Shape Educators Desk 28 1/4" D b/b/f pedestal, locks & center drawer	SED6630BL-BBF	30"	66"	29"	\$2458	180	E
	SED7230BL-BBF	30"	72"	29"	\$2588	190	E
D-Shape Educators Desk 28 1/4" D f/f pedestal, bookcase, locks & center drawer	SED7230FCL-FF	30"	72"	29"	\$3412	260	E
D-Shape Educators Desk 28 1/4" D b/b/f pedestal, bookcase, locks & center drawer	SED7230BCL-BBF	30"	72"	29"	\$3552	260	E

Voyager Series

introduction



to order

1. Item Number
2. Pull Style
3. Paint Finish
4. Laminate
5. Edge Finish

example SED6630FL-FF - FL - 5503 - HS - 4072

ITEM NUMBER	PULL STYLE	PAINT FINISH	LAMINATE	EDGE FINISH
SED6630FL-FF	FL	5503	HS	4072

please separate each item with a dash

drawer pull options

MODEL DESCRIPTION

FL Full

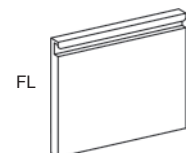

Voyager Series

butcher block table

DESCRIPTION	ITEM #	D	W	H	PRICE	SHIP WT.	LEAD TIME*
Voyager table, 36d x 48w, butcher block top and locking casters. H-frame, no storage options. Platinum frame only.	MK3.3648.P2	36"	48"	36"	\$1566		



Voyager table, 36d x 60w, butcher block top and locking casters. H-frame, no storage options. Platinum frame only.	MK3.3660.P2	36"	60"	36"	\$1636		
--	-------------	-----	-----	-----	--------	--	--



Voyager table, 36d x 72w, laminate top and locking casters. H-frame, no storage options. Platinum frame only.	MK3.3672.P2	36"	72"	36"	\$1730		
---	-------------	-----	-----	-----	--------	--	--



to order 1. Item Number **MK3.3660.P2**
ITEM NUMBER

example

Voyager Series

laminate table

DESCRIPTION	ITEM #	D	W	H	PRICE	SHIP WT.	LEAD TIME*
Voyager table, 36d x 48w, butcher laminate top and locking casters. H-frame, no storage options. Platinum frame only.	MK3L.3648.P2	36"	48"	35.75"	\$1230		



Voyager table, 36d x 60w, laminate top and locking casters. H-frame, no storage options. Platinum frame only.	MK3L.3660.P2	36"	60"	35.75"	\$1288		
---	--------------	-----	-----	--------	--------	--	--

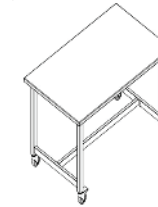

Voyager table, 36d x 72w, laminate top and locking casters. H-frame, no storage options. Platinum frame only.	MK3L.3672.P2	36"	72"	35.75"	\$1358		
---	--------------	-----	-----	--------	--------	--	--



to order 1. Item Number **MK3.3660.P2**
ITEM NUMBER

example

Voyager Series

adjustable ht. butcher block table

DESCRIPTION	ITEM #	D	W	H	PRICE	SHIP WT.	LEAD TIME*
Voyager table, 36d x 60w, butcher block top and locking casters. Adjustable Height, no storage options. Platinum frame only.	VY1.3660.P2	36"	60"	30"-40"	\$2230		

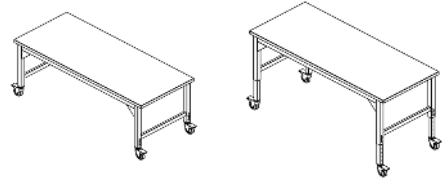

Voyager table, 36d x 72w, butcher block top and locking casters. Adjustable height, no storage options. Platinum frame only.	VY1.3672.P2	36"	72"	30"-40"	\$2480		
--	-------------	-----	-----	---------	--------	--	--

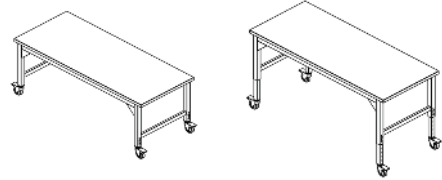

to order 1. Item Number

example **MK3.3660.P2**
ITEM NUMBER

Voyager Series

adj ht. laminate table

DESCRIPTION	ITEM #	D	W	H	PRICE	SHIP WT.	LEAD TIME*
Voyager table, 36d x 60w, standard laminate top and locking casters. Adjustable Height, no storage options. Platinum frame only.	VY1L.3660.P2	36"	60"	29.25"-39.25"	\$1882		

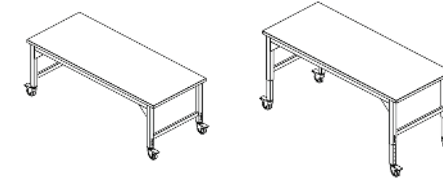

Voyager table, 36d x 72w, standard laminate top and locking casters. Adjustable height, no storage options. Platinum frame only.	VY1L.3672.P2	36"	72"	29.25"-39.25"w	\$1952		
--	--------------	-----	-----	----------------	--------	--	--

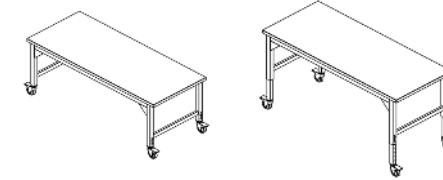





to order 1. Item Number

example **MK3.3660.P2**
ITEM NUMBER

Voyager Series

storage carts

DESCRIPTION	ITEM #	D	W	H	PRICE	SHIP WT.	LEAD TIME*
Short Storage Cart w/ 2 shelves, magnetic white board backing & locking casters. Platinum frame.	MBC.3642.P2	19"	36"	42.5"	\$1014		
							
Tall Storage Cart w/ 1 fixed and 2 adjustable shelves, magnetic white board backing & locking casters. Platinum frame.	MBC.4159.P2	19"	41"	59.5"	\$1790		
							
Short Storage Cart w/ 24 - 3" bins, magnetic white board backing & locking casters. Platinum frame.	MBSA8.4142.P2	19"	41"	42.5"	\$1796		
							
Tall Storage Cart w/ 36 - 3" bins, magnetic white board backing & locking casters. Platinum frame.	MBSA12.4159.P2	19"	41"	59.5"	\$2396		
							

to order 1. Item Number **MK3.3660.P2** example
ITEM NUMBER

To order additional bins

MODEL	DESCRIPTION	PRICE EACH
BINPK3	Clear Tote Bin - 3"H x 16.81"L x 12.28"W Pack of 6	\$120.00

Price List

February 2023

2.8.23