

WORKSURFACES

March 2023 Price List

AIS

PRODUCT INFORMATION

Universal Worksurfaces Statement of Line 3
Universal Worksurface Finish Options 4
Universal Worksurfaces Product Details 5
Universal Worksurfaces Grommet Specifications 6

Worksurfaces

Rectangular Worksurfaces 8
Rectangular Worksurfaces for Height Adjustable Tables 10
System Specific Extended Rectangular Worksurfaces 11
System Specific Bullpen Surfaces 12
Rectilinear and Extended Rectilinear Corners 13
Curvilinear Corners 14
Cockpit Corners. 15
Extended Curvilinear Corners. 16
D-Tops and P-Tops 17
System Specific Spanner Half Moons 18
Rounds and 120° Corners 19
Shelf Surfaces and Rectangular / Radius Transactions. 20
Grommet Hole Covers 21

WARRANTY & TERMS AND CONDITIONS

For Warranty & Terms and Conditions please visit:
<https://aiscmsprod.blob.core.windows.net/infocenter/AISTermsWarranty.pdf>

WORKSURFACES

2MM EDGE WORKSURFACES

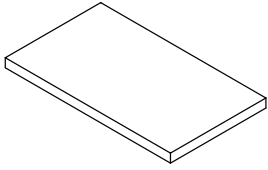

Rectangular Worksurfaces

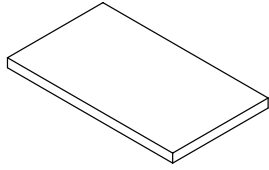

Extended Rectangular Worksurfaces
System Specific

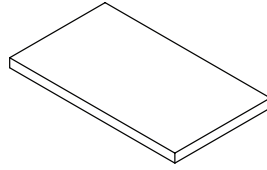

Bullpen Surfaces
System Specific

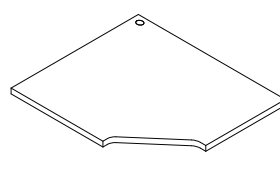

Standard Rectilinear Corners Type B

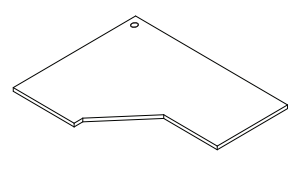

Extended Rectilinear Corners
Left or Right Hand

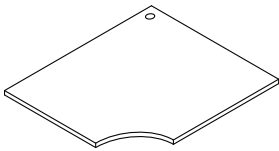

Curvilinear Corners Type A

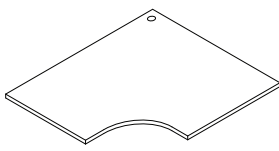

Standard Curvilinear Corners Type B

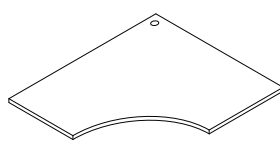

Cockpit Corner

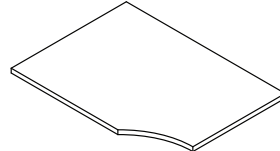

Cockpit Corner Returns
Left or Right Hand

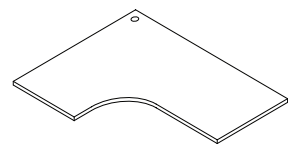

Extended Curvilinear Corners
Left or Right Hand

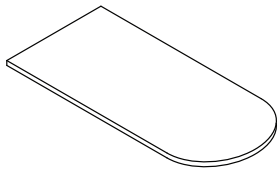

D-Top

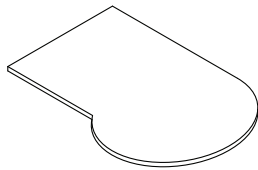

P-Top
Left or Right Hand

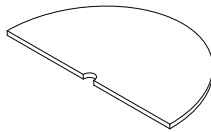

Spanner Half Moons
System Specific

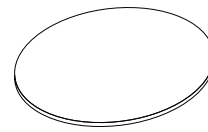

Rounds

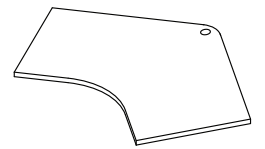

Standard 120° C, 90° L, 90° R Corner

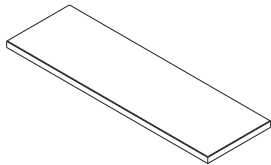

Shelf Surface

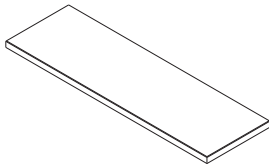

Rectangular Transaction

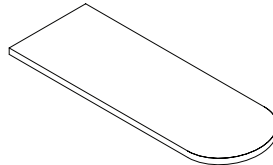

Radius Transaction

Worksurface Laminate Options

WORKSURFACE LAMINATE OPTIONS	
Name	Grade
Absolute Acajou	A
Aimtoo Savatre	A
Black	A
Brazilwood	A
Chalk	A
Corporate Walnut	A
Dark Rum Cherry	A
Field Elm	A
Grand Cherry	A
Grey Elm	A
Landmark	A
Leave Likatre	A
Linen	A
Looks Likatre	A
Maritime Dune	A
Midwest Maple	A
Neo Walnut	A
Phantom Ecrú	A
Phantom Pearl	A
Storm	A
Summer Drops	A
True White	A
Trytoo Savatre	A
White Chocolate	A
Asian Night	B
Asian Sand	B
Beige Granite	B
Colombian Walnut	B

WORKSURFACE LAMINATE OPTIONS	
Name	Grade
Fonthill Pear	B
Grey Mesh	B
Gridlock in L.A.	B
Madagascar	B
Mahogany Clove	B
Monticello Maple	B
Nightfall	B
Paris White Potteryware	B
Pewter Mesh	B
Recon Oak	B
Shadow	B
Sunset	B
Titanium EV	B
Tungsten EV	B
White Spektrum	B
Windswept Pewter	B
Yorkshire Cherry	B
Ebony	C
Bright White (Writable Surface)	C
Pecan Woodline	C
Strand Burnt	C
Strand Wedge	C
Strand Wheat	C
Twill Earthen	C
Twill Graphite	C
Twill Sarum	C
Warm White	C

EDGE BAND OPTIONS		
Name	Color Code	Grade
Absolute Acajou	AA	A
Aimtoo Savatre	AS	A
Black	BK	A
Brazilwood	BZ	A
Chalk	CK	A
Corporate Walnut	CT	A
Dark Rum Cherry	DR	A
Dark Tone	DT	A
Field Elm	FE	A
Grand Cherry	GC	A
Grey Elm	GE	A
Grey Value 1	GV1	A
Landmark	LM	A
Leave Likatre	LV	A

EDGE BAND OPTIONS		
Name	Color Code	Grade
Light Tone	LT	A
Linen	LN	A
Looks Likatre	LK	A
Maritime Dune	MD	A
Medium Tone	MT	A
Midwest Maple	MM	A
Neo Walnut	NW	A
Phantom Ecrú	PE	A
Phantom Pearl	PP	A
Satin White / True White	SW/TW	A
Storm	ST	A
Summer Drops	SD	A
Trytoo Savatre	TS	A
White Chocolate	WC	A

Custom Edgeband Options

- Custom match non-standard edgebands must be submitted as a special. Pricing varies based on edge thickness and finish.
- Minimum order size for any custom color is \$75,000.00 list. Extended lead-time will apply.

Product Detail 1
2mm Edge Details

2 mm edge banding (approximately 3/32") is made of rigid, dent resistant PVC. Impregnated colors match panel trim colors and help to reduce visible scratches. Edges are rounded/beveled for comfort. 2mm edging is available on all worksurface shapes. All surfaces shown are 2mm unless noted otherwise.

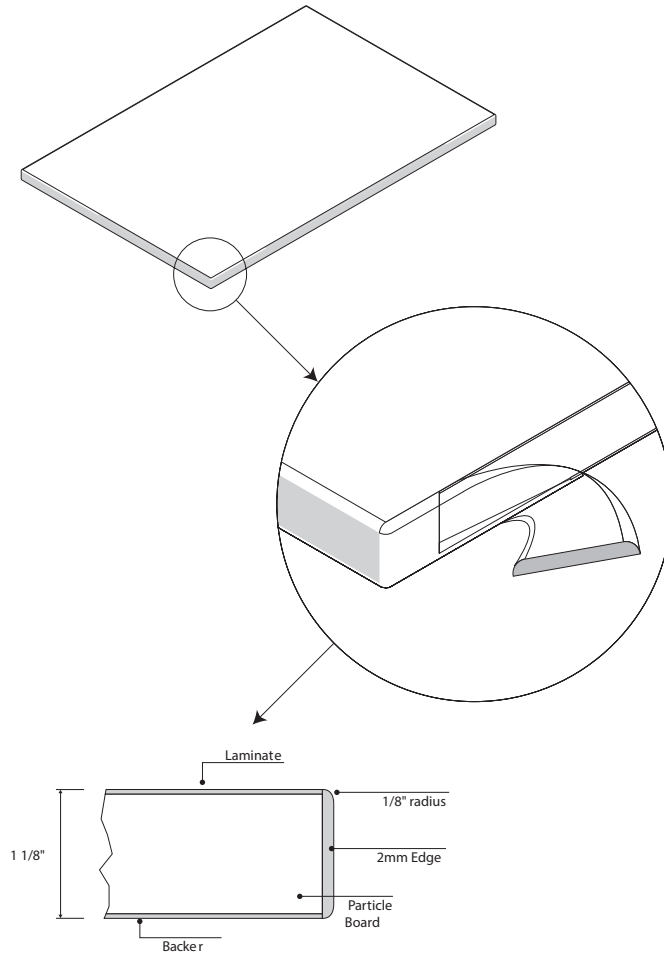

Product Detail 2
Worksurfaces for Height Adjustable Tables

Worksurfaces for Height Adjustable Tables require a 1" gap on all sides to prevent pinch points. When placing two Worksurfaces for Height Adjustable Tables side-by-side each worksurface requires the 1" gap resulting in a 2" gap between worksurfaces. See examples below.

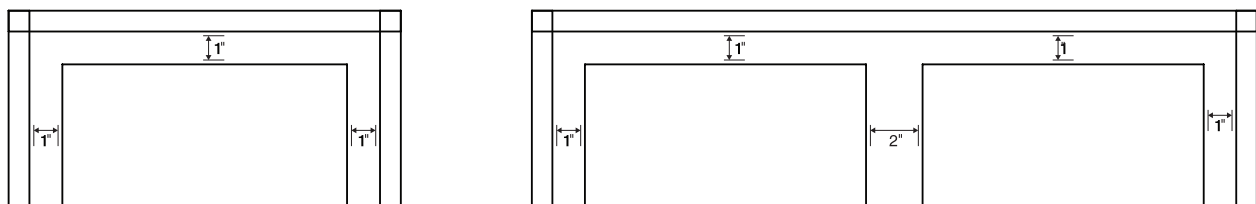

Universal Worksurfaces Grommet Specifications

RECTANGULAR GROMMET OPTIONS

Option	Location	List
A	No Grommets	-
B	Location 1	+38
C	Location 2	+38
D	Location 3	+38
E	Locations 2 and 3	+76
F	Locations 1, 2 and 3	+114
G	Locations 1 and 2	+76
H	Locations 1 and 3	+76

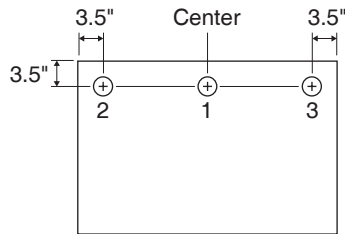

Applies to: Rectangulars, Extended Rectangulars, Cockpit Returns, 120° Returns

CORNER GROMMET OPTIONS

Option	Location	List
A	No Grommets	-
B	Location 1 (Default)	-
C	Location 1 and 2	+38
D	Location 1 and 3	+38
E	Locations 1, 2 and 3	+76

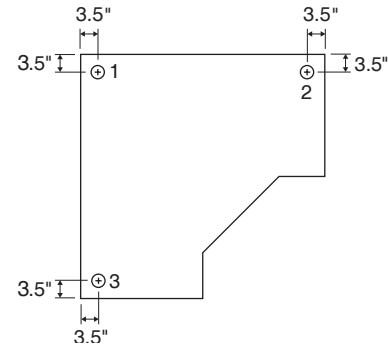

Applies to: All Corners (Rectilinear, Curvilinear, Depth Transitions, Cockpit Corners, 120° Corners, 135° Corners, Corner Keyboards)

EXTENDED LEFT HAND CORNER GROMMET OPTIONS

Option	Location	List
A	No Grommets	-
B	Location 1 (Default)	-
C	Location 1 and 2	+38
D	Location 1 and 4	+38
E	Locations 1 and 3*	+38
F	Locations 1, 2 and 4	+76
G	Locations 1, 3 and 4*	+76

*Available on 72" Wide only.

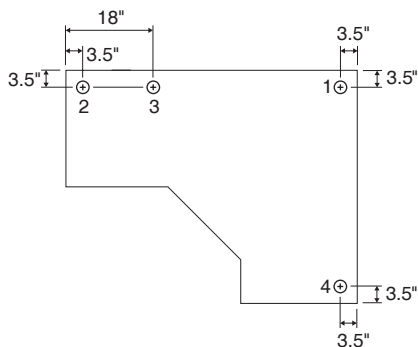

Applies to: All Extended Left Hand Corners (Rectilinear, Curvilinear, Depth Transitions, 120° Corners, 135° Corners). Excludes all Extended D-Tops.

EXTENDED RIGHT HAND CORNER GROMMET OPTIONS

Option	Location	List
A	No Grommets	-
B	Location 1 (Default)	-
C	Location 1 and 2	+38
D	Location 1 and 4	+38
E	Locations 1 and 3*	+38
F	Locations 1, 2 and 4	+76
G	Locations 1, 3 and 4*	+76

*Available on 72" Wide only.

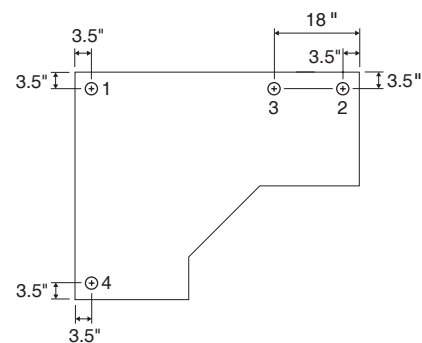

Applies to: All Extended Right Hand Corners (Rectilinear, Curvilinear, Depth Transitions, 120° Corners, 135° Corners). Excludes all Extended D-Tops.

Notes

- Grommet holes are 2 3/4" outside diameter with a 2 5/8" inside diameter (inside sleeve).
- Grommet covers are available in either grey or black and are included with grommet options.
- Grommet covers may also be purchased separately.

Grommet Specifications

D-TOP GROMMET OPTIONS

Option	Location	List
A	No Grommets	-
B	Location 1	+38
C	Location 2	+38
D	Locations 1 and 2	+76

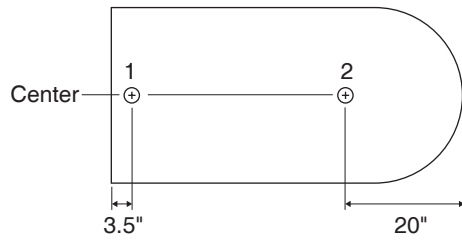

Applies to: D-Tops

P-TOP GROMMET OPTIONS

Option	Location	List
A	No Grommets	-
B	Location 1	+38
C	Location 2	+38
D	Locations 1 and 2	+76

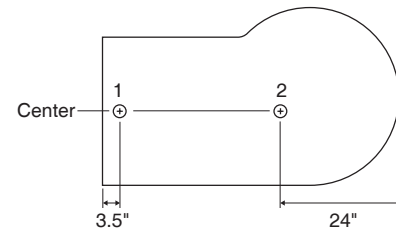

Applies to: P-Tops

Notes

- Grommet holes are 2 3/4" outside diameter with a 2 5/8" inside diameter (inside sleeve).
- Grommet covers are available in either grey or black and are included with grommet options.
- Grommet covers may also be purchased separately.

Rectangular Worksurfaces

18" DEEP RECTANGULAR WORKSURFACES

D	W	Model Number	List	Grade C Laminate
18	18	W-WS1818	321	+21
18	24	W-WS1824	350	+21
18	30	W-WS1830	420	+28
18	36	W-WS1836	455	+28
18	42	W-WS1842	496	+30
18	48	W-WS1848	538	+33
18	54	W-WS1854	601	+41
18	60	W-WS1860	663	+41
18	66	W-WS1866	754	+46
18	72	W-WS1872	780	+51
18	78	W-WS1878	881	+58
18	84	W-WS1884	942	+58
18	90	W-WS1890	992	+68
18	96	W-WS1896	1,103	+68

24" DEEP RECTANGULAR WORKSURFACES

D	W	Model Number	List	Grade C Laminate
24	24	W-WS2424	354	+21
24	30	W-WS2430	423	+25
24	36	W-WS2436	461	+28
24	42	W-WS2442	501	+30
24	48	W-WS2448	544	+33
24	54	W-WS2454	605	+41
24	60	W-WS2460	666	+41
24	66	W-WS2466	758	+46
24	72	W-WS2472	829	+51
24	78	W-WS2478	886	+54
24	84	W-WS2484	947	+58
24	90	W-WS2490	960	+68
24	96	W-WS2496	1,107	+68

30" DEEP RECTANGULAR WORKSURFACES

D	W	Model Number	List	Grade C Laminate
30	24	W-WS3024	423	+25
30	30	W-WS3030	498	+30
30	36	W-WS3036	543	+34
30	42	W-WS3042	642	+39
30	48	W-WS3048	696	+42
30	54	W-WS3054	807	+50
30	60	W-WS3060	807	+50
30	66	W-WS3066	911	+56
30	72	W-WS3072	991	+61
30	78	W-WS3078	1,201	+69
30	84	W-WS3084	1,396	+87
30	90	W-WS3090	1,417	+96
30	96	W-WS3096	1,546	+96

36" DEEP RECTANGULAR WORKSURFACES

D	W	Model Number	List	Grade C Laminate
36	24	W-WS3624	461	+28
36	30	W-WS3630	558	+34
36	36	W-WS3636	653	+40
36	42	W-WS3642	810	+50
36	48	W-WS3648	869	+53
36	54	W-WS3654	994	+61
36	60	W-WS3660	1,101	+68
36	66	W-WS3666	1,161	+72
36	72	W-WS3672	1,292	+80
36	78	W-WS3678	1,428	+88
36	84	W-WS3684	1,547	+96
36	90	W-WS3690	1,584	+99
36	96	W-WS3696	1,717	+99

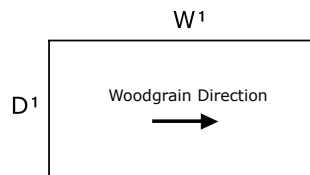

Specify

- Laminate Selection
- Color Selection for 2mm Edge
- Additional Grommet Locations (+38)
- Grommet Cover Color (if applicable)

Notes

- Worksurface support hardware is specified separately.
- Grommet holes with covers are specified as options.
- It is highly recommended that a center support be used on all worksurfaces greater than 48" width.
- When spanning panel connections with a worksurface greater than 48" wide, an additional center cantilever is recommended for added support. Otherwise, a U-channel is recommended for additional center worksurface support.
- It is not recommended that 36", 42" and 48" deep worksurfaces be cantilevered to panels.
- If these size depths must be panel hung, it is highly recommended that an additional front support, such as a combination leg or full laminate support panel, also be specified.

Rectangular Worksurfaces

42" DEEP RECTANGULAR WORKSURFACES

D	W	Model Number	List	Grade C Laminate
42	24	W-WS4224	477	+30
42	30	W-WS4230	582	+39
42	36	W-WS4236	685	+50
42	42	W-WS4242	845	+52
42	48	W-WS4248	903	+57
42	54	W-WS4254	1,038	+63
42	60	W-WS4260	1,291	+67
42	66	W-WS4266	1,212	+68
42	72	W-WS4272	1,355	+77
42	84	W-WS4284	1,616	+96
42	90	W-WS4290	1,768	+99
42	96	W-WS4296	1,664	+99

48" DEEP RECTANGULAR WORKSURFACES

D	W	Model Number	List	Grade C Laminate
48	24	W-WS4824	544	+33
48	30	W-WS4830	696	+42
48	36	W-WS4836	869	+53
48	42	W-WS4842	924	+57
48	48	W-WS4848	977	+60
48	54	W-WS4854	1,099	+68
48	60	W-WS4860	1,088	+67
48	66	W-WS4866	1,212	+75
48	72	W-WS4872	1,240	+77
48	84	W-WS4884	1,557	+97
48	90	W-WS4890	1,735	+99
48	96	W-WS4896	1,603	+99

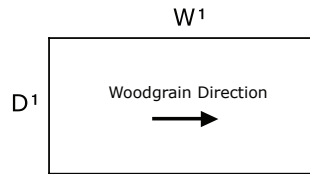

Specify	Notes
<ul style="list-style-type: none"> • Laminate Selection • Color Selection for 2mm Edge • Additional Grommet Locations (+38) • Grommet Cover Color (if applicable) 	<ul style="list-style-type: none"> • Worksurface support hardware is specified separately. • Grommet holes with covers are specified as options. • It is highly recommended that a center support be used on all worksurfaces greater than 48" width. • When spanning panel connections with a worksurface greater than 48" wide, an additional center cantilever is recommended for added support. Otherwise, a U-channel is recommended for additional center worksurface support. • It is not recommended that 36", 42" and 48" deep worksurfaces be cantilevered to panels. • If these size depths must be panel hung, it is highly recommended that an additional front support, such as a combination leg or full laminate support panel, also be specified.

Rectangular Worksurfaces for Height Adjustable Tables

RECTANGULAR WORKSURFACES FOR HEIGHT ADJUSTABLE TABLES

D'	W'	Model Number	List
23	46	W-WS2346	544
23	52	W-WS2352	629
23	58	W-WS2358	666
23	64	W-WS2364	758
23	70	W-WS2370	829
29	46	W-WS2946	696
29	52	W-WS2952	714
29	58	W-WS2958	807
29	64	W-WS2964	911
29	70	W-WS2970	991

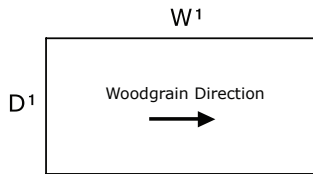

Specify	Notes
<ul style="list-style-type: none"> • Laminate Selection • Color Selection for 2mm Edge • Grommet Location • Color Selection for Grommet Cover 	<ul style="list-style-type: none"> • Rectangular Worksurfaces for Height Adjustable Tables have a 1 1/8" thickness. • Height adjustable worksurface support base is specified separately. • Grommet holes with covers are specified as options. • These worksurfaces are for use with height adjustable table bases only. • Worksurfaces for Height Adjustable Tables require a 1" gap around to prevent pinch points. See example in Product Details.

System Specific Extended Rectangular Worksurfaces

⚠ The following worksurface is designed for use with Matrix systems only:

⚠ The following worksurface is designed for use with MWall/Divi systems only:

MATRIX SYSTEM EXTENDED RECTANGULAR WORKSURFACE

MWALL AND DIVI SYSTEM EXTENDED RECTANGULAR WORKSURFACE

D	W	Model Number	List	Grade C Laminate
24	27 1/4	W-WSE2424MX	359	+23
24	33 1/4	W-WSE2430MX	430	+28
24	39 1/4	W-WSE2436MX	466	+30
24	45 1/4	W-WSE2442MX	512	+33
24	51 1/4	W-WSE2448MX	556	+36
24	57 1/4	W-WSE2454MX	625	+41
24	63 1/4	W-WSE2460MX	682	+45
24	69 1/4	W-WSE2466MX	777	+51
24	75 1/4	W-WSE2472MX	847	+56
24	87 1/4	W-WSE2484MX	971	+64
30	27 1/4	W-WSE3024MX	479	+31
30	33 1/4	W-WSE3030MX	509	+33
30	39 1/4	W-WSE3036MX	565	+37
30	45 1/4	W-WSE3042MX	621	+41
30	51 1/4	W-WSE3048MX	670	+44
30	57 1/4	W-WSE3054MX	779	+51
30	63 1/4	W-WSE3060MX	829	+54
30	69 1/4	W-WSE3066MX	934	+62
30	75 1/4	W-WSE3072MX	1,012	+67
30	87 1/4	W-WSE3084MX	1,329	+88

D	W	Model Number	List	Grade C Laminate
24	26 3/16	W-WSE2424MW	383	+23
24	32 3/16	W-WSE2430MW	461	+28
24	38 3/16	W-WSE2436MW	498	+30
24	44 3/16	W-WSE2442MW	546	+33
24	50 3/16	W-WSE2448MW	593	+36
24	56 3/16	W-WSE2454MW	666	+41
24	62 3/16	W-WSE2460MW	728	+45
24	68 3/16	W-WSE2466MW	830	+51
24	74 3/16	W-WSE2472MW	904	+56
24	86 3/16	W-WSE2484MW	1,036	+64
30	26 3/16	W-WSE3024MW	512	+31
30	32 3/16	W-WSE3030MW	544	+33
30	38 3/16	W-WSE3036MW	603	+37
30	44 3/16	W-WSE3042MW	664	+41
30	50 3/16	W-WSE3048MW	714	+44
30	56 3/16	W-WSE3054MW	831	+51
30	62 3/16	W-WSE3060MW	884	+54
30	68 3/16	W-WSE3066MW	995	+62
30	74 3/16	W-WSE3072MW	1,083	+67
30	86 3/16	W-WSE3084MW	1,420	+88

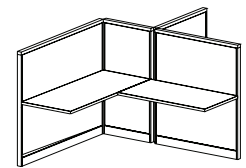
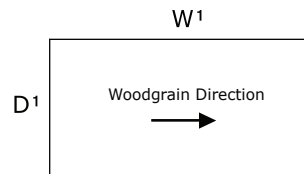
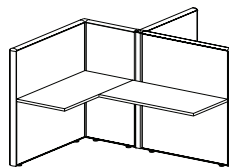
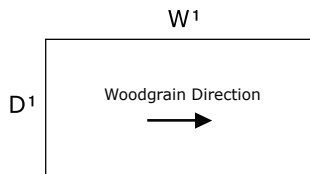

Specify

Notes

- Laminate Selection
- Color Selection for 2mm Edge
- Additional Grommet Locations (+38)
- Grommet Cover Color (if applicable)

- Worksurface support hardware is specified separately.
- Grommet holes with covers are specified as options.
- Extended rectangulars are designed to compensate for the gap created when a panel is inserted into a panel run at a 3-way connection.
- Be sure to order worksurface that corresponds to the system you are specifying.
- It is highly recommended that a center support be used on all worksurfaces greater than 48" wide.
- When spanning panel connections with a worksurface greater than 48" wide, an additional center cantilever is recommended for added support. Otherwise a U-Channel is recommended for additional center worksurface support.

System Specific Bullpen Surfaces

 The following worksurface is designed for use with Divi systems only:

DIVI BULLPEN SURFACES						
D	W	Number of Panels	Model Number	List	Grade C Laminate	
24	24 1/8	1	W-WSDV2424	380	+21	
24	30 1/8	1	W-WSDV2430	445	+25	
24	36 1/8	1	W-WSDV2436	485	+28	
24	42 1/8	1	W-WSDV2442	526	+30	
24	48 1/8	1	W-WSDV2448	567	+33	
24	54 1/4	2	W-WSDV2454	693	+41	
24	60 1/8	1	W-WSDV2460A	693	+41	
24	60 1/4	2	W-WSDV2460B	693	+41	
24	66 1/4	2	W-WSDV2466	783	+46	
24	72 1/4	2	W-WSDV2472A	850	+51	
24	72 3/8	3	W-WSDV2472B	850	+51	
24	78 1/4	2	W-WSDV2478A	911	+54	
24	78 3/8	3	W-WSDV2478B	911	+54	
24	84 1/4	2	W-WSDV2484A	972	+58	
24	84 3/8	3	W-WSDV2484B	972	+58	

 The following worksurface is designed for use with Divi systems only:

DIVI BULLPEN SURFACES						
D	W	Number of Panels	Model Number	List	Grade C Laminate	
30	24 1/8	1	W-WSDV3024	445	+25	
30	30 1/8	1	W-WSDV3030	524	+30	
30	36 1/8	1	W-WSDV3036	584	+34	
30	42 1/8	1	W-WSDV3042	665	+39	
30	48 1/8	1	W-WSDV3048	715	+42	
30	54 1/4	2	W-WSDV3054	835	+42	
30	60 1/8	1	W-WSDV3060A	835	+50	
30	60 1/4	2	W-WSDV3060B	835	+50	
30	66 1/4	2	W-WSDV3066	937	+58	
30	72 1/4	2	W-WSDV3072A	1,019	+61	
30	72 3/8	3	W-WSDV3072B	1,019	+61	
30	78 1/4	2	W-WSDV3078A	1,228	+69	
30	78 3/8	3	W-WSDV3078B	1,228	+69	
30	84 1/4	2	W-WSDV3084A	1,422	+87	
30	84 3/8	3	W-WSDV3084B	1,422	+87	

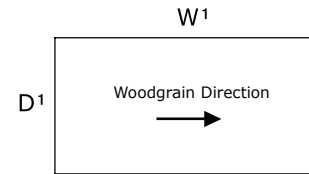
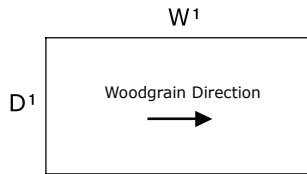

Specify

- Laminate Selection
- Color Selection for 2mm Edge
- Additional Grommet Locations (+38)
- Grommet Cover Color (if applicable)

Notes

- Worksurface support hardware is specified separately.
- Grommet holes with covers are specified as options.
- Bullpen Rectangular surfaces are designed to compensate for the gap created by natural panel creep for system specific (MWall or Divi) panels only.
- It is highly recommended that a center support be used on all workspaces greater than 48" wide.
- When spanning panel connections with a worksurface greater than 48" wide, an additional center cantilever is recommended for added support. Otherwise a U-Channel is recommended for additional center worksurface support.

Rectilinear and Extended Rectilinear Corners

EXTENDED RECTILINEAR LEFT HAND CORNERS

D ¹	W ¹	W ²	F	Model Number	List	Grade C Laminate
24	36	42	17	W-WSCE244236	796	+50
24	36	48	17	W-WSCE244836	801	+51
24	36	60	17	W-WSCE246036	934	+59
24	36	72	17	W-WSCE247236	1,304	+83
24	42	48	21.25	W-WSCE244842	972	+61
24	42	60	21.25	W-WSCE246042	1,145	+72
24	42	72	21.25	W-WSCE247242	1,319	+83
24	48	60	21.25	W-WSCE246048	1,150	+73
24	48	72	21.25	W-WSCE247248	1,322	+84

EXTENDED RECTILINEAR RIGHT HAND CORNERS

D ¹	W ¹	W ²	F	Model Number	List	Grade C Laminate
24	36	42	17	W-WSCE243642	796	+50
24	36	48	17	W-WSCE243648	801	+51
24	36	60	17	W-WSCE243660	934	+59
24	36	72	17	W-WSCE243672	1,304	+83
24	42	48	21.25	W-WSCE244248	972	+61
24	42	60	21.25	W-WSCE244260	1,145	+72
24	42	72	21.25	W-WSCE244272	1,319	+83
24	48	60	21.25	W-WSCE244860	1,150	+73
24	48	72	21.25	W-WSCE244872	1,322	+84

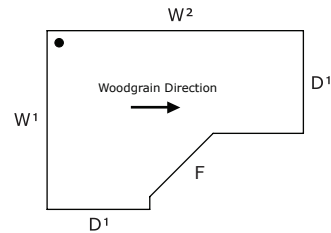
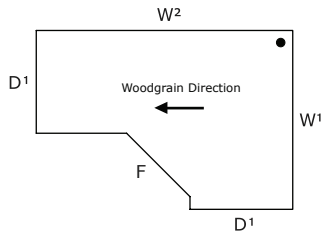

Specify

Notes

- Laminate Selection
- Color Selection for 2mm Edge
- Additional Grommet Locations (+38)
- Grommet Cover Color (if applicable)
- Worksurface support hardware is specified separately.
- Rear corner grommet hole with cover is included.
- Additional grommet holes with covers are specified as options.

STANDARD RECTILINEAR CORNER TYPE B

D ¹	W ¹	F	Model Number	List	Grade C Laminate
24	36	10.25	W-WSC2436B	731	+45
24	42	18.75	W-WSC2442B	879	+54
24	48	18.75	W-WSC2448	978	+60
30	42	10.25	W-WSC3042B	975	+60
30	48	18.75	W-WSC3048B	1,107	+69

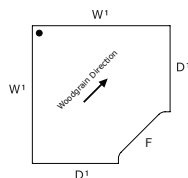

Specify

Notes

- Laminate Selection
- Color Selection for 2mm Edge
- Additional Grommet Locations (+38)
- Grommet Cover Color (if applicable)
- Worksurface support hardware is specified separately.
- Rear corner grommet hole with cover is included.
- Additional grommet holes with covers are specified as options.

Curvilinear Corners

CURVILINEAR CORNER TYPE A

D'	W'	Model Number	List	Grade C Laminate
24	36	W-WSCC2436	765	+47
30	42	W-WSCC3042	1,018	+63

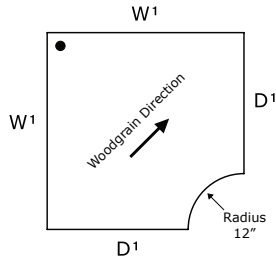

STANDARD CURVILINEAR CORNER TYPE B

D'	W'	Model Number	List	Grade C Laminate
24	42	W-WSCC2442	924	+58
24	48	W-WSCC2448	1,021	+64
30	48	W-WSCC3048	1,164	+72

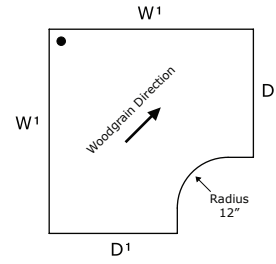

Specify

Notes

- Laminate Selection
- Color Selection for 2mm Edge
- Additional Grommet Locations (+38)
- Grommet Cover Color (if applicable)

- Worksurface support hardware is specified separately.
- Rear corner grommet hole with cover is included.
- Additional grommet holes with covers are specified as options.

Cockpit Corners

LEFT HAND COCKPIT CORNER RETURNS

D ¹	D ²	W ¹	Model Number	List	Grade C Laminate
24	30	36	W-WSCRL36	826	+54
24	30	42	W-WSCRL42	904	+60
24	30	48	W-WSCRL48	990	+66
24	30	60	W-WSCRL60	1,073	+71
24	30	66	W-WSCRL66	1,161	+77
24	30	72	W-WSCRL72	1,240	+83
24	30	84	W-WSCRL84	1,327	+88
24	30	96	W-WSCRL96	1,411	+94

RIGHT HAND COCKPIT CORNER RETURNS

D ¹	D ²	W ¹	Model Number	List	Grade C Laminate
24	30	36	W-WSCRR36	826	+54
24	30	42	W-WSCRR42	904	+60
24	30	48	W-WSCRR48	990	+66
24	30	60	W-WSCRR60	1,073	+71
24	30	66	W-WSCRR66	1,161	+77
24	30	72	W-WSCRR72	1,240	+83
24	30	84	W-WSCRR84	1,327	+88
24	30	96	W-WSCRR96	1,411	+94

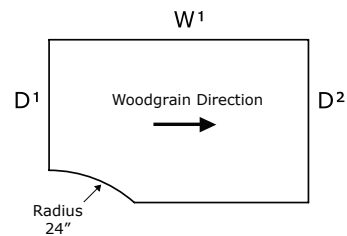
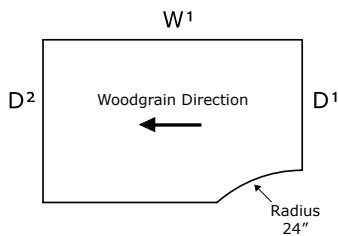

COCKPIT CORNER

D ¹	W ¹	Model Number	List	Grade C Laminate
24	48	W-WSCC48	961	+70

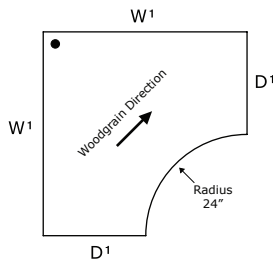

Specify

Notes

- Laminate Selection
- Color Selection for 2mm Edge
- Additional Grommet Locations (+38)
- Grommet Cover Color (if applicable)
- Worksurface support hardware is specified separately.
- Rear corner grommet hole with cover is included.
- Additional grommet holes with covers are specified as options.

Extended Curvilinear Corners

EXTENDED CURVILINEAR LEFT HAND CORNER

D ¹	W ¹	W ²	Model Number	List	Grade C Laminate
24	36	42	W-WSCCE244236	836	+53
24	36	48	W-WSCCE244836	840	+53
24	36	60	W-WSCCE246036	984	+62
24	36	72	W-WSCCE247236	1,373	+87
24	42	48	W-WSCCE244842	1,019	+64
24	42	60	W-WSCCE246042	1,199	+76
24	42	72	W-WSCCE247242	1,380	+87
24	48	60	W-WSCCE246048	1,210	+76
24	48	72	W-WSCCE247248	1,385	+88

EXTENDED CURVILINEAR RIGHT HAND CORNER

D ¹	W ¹	W ²	Model Number	List	Grade C Laminate
24	36	42	W-WSCCE243642	836	+53
24	36	48	W-WSCCE243648	840	+53
24	36	60	W-WSCCE243660	984	+62
24	36	72	W-WSCCE243672	1,373	+87
24	42	48	W-WSCCE244248	1,019	+64
24	42	60	W-WSCCE244260	1,199	+76
24	42	72	W-WSCCE244272	1,380	+87
24	48	60	W-WSCCE244860	1,210	+76
24	48	72	W-WSCCE244872	1,385	+88

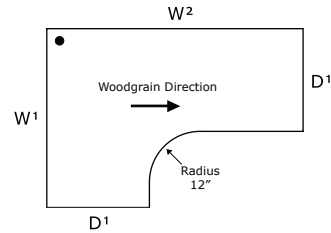
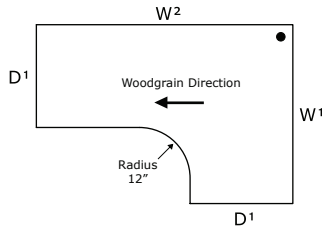

Specify

- Laminate Selection
- Color Selection for 2mm Edge
- Additional Grommet Locations (+38)
- Grommet Cover Color (if applicable)

Notes

- Worksurface support hardware is specified separately.
- Rear corner grommet hole with cover is included.
- Additional grommet holes with covers are specified as options.

D-Tops and P-Tops

D-TOPS				
D'	W'	Model Number	List	Grade C Laminate
24	60	W-WSD2460	831	+51
24	66	W-WSD2466	868	+54
24	72	W-WSD2472	934	+58
24	84	W-WSD2484	1,082	+67
30	60	W-WSD3060	854	+53
30	66	W-WSD3066	934	+58
30	72	W-WSD3072	1,016	+63
30	84	W-WSD3084	1,167	+70

P-TOPS						
Hand	D'	D ²	W'	Model Number	List	Grade C Laminate
Left	30	36	60	W-WSPL3060	1,088	+67
Left	30	36	66	W-WSPL3066	1,169	+72
Left	30	36	72	W-WSPL3072	1,248	+78
Left	30	36	84	W-WSPL3084	1,461	+91
Right	30	36	60	W-WSPR3060	1,088	+67
Right	30	36	66	W-WSPR3066	1,169	+72
Right	30	36	72	W-WSPR3072	1,248	+78
Right	30	36	84	W-WSPR3084	1,461	+91

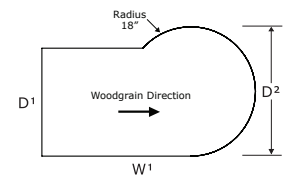
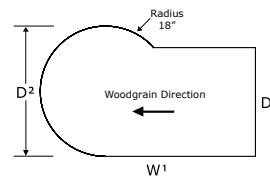
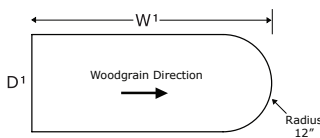

Specify

Notes

- Laminate Selection
- Color Selection for 2mm Edge
- Additional Grommet Locations (+38)
- Grommet Cover Color (if applicable)

- Worksurface support hardware is specified separately.
- Grommet holes with covers are specified as options.

System Specific Spanner Half Moons

⚠ The following worksurface is designed for use with Divi systems only:

DIVI SPANNER HALF MOONS

D¹	D²	W¹	Model Number	List	Grade C Laminate
24	25 1/8	50 1/8	W-WSHM2450DV	778	+48
30	31 1/8	61 3/4	W-WSHM3062DV	833	+51

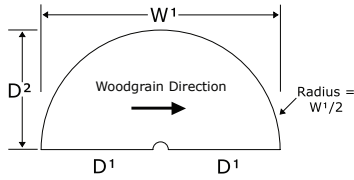

Specify **Notes**

- | | |
|--|---|
| <ul style="list-style-type: none"> • Laminate Selection • Color Selection for 2mm Edge | <ul style="list-style-type: none"> • For use with Divi. • Worksurface support hardware is specified separately. |
|--|---|

Rounds and 120° Corners

ROUNDS

W'	Model Number	List	Grade C Laminate	Swing Hole
30	C-TBLR30	616	+39	+38
36	C-TBLR36	884	+56	+38
42	C-TBLR42	1,055	+67	+38
48	C-TBLR48	1,103	+70	+38

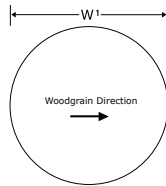

Specify

- Laminate Selection
- Color Selection for 2mm Edge

Notes

- Worksurface support hardware is specified separately.

120° C, 90° L, 90° R CORNER

D'	W'	Model Number	List	Grade C Laminate
24	36	W-WSYCC2436	765	+47
24	42	W-WSYCC2442	924	+58
24	48	W-WSYCC2448	1,021	+64
30	42	W-WSYCC3042	1,018	+63
30	48	W-WSYCC3048	1,164	+72

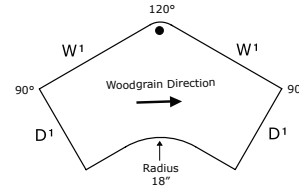

Specify

- Laminate Selection
- Color Selection for 2mm Edge
- Additional Grommet Locations (+38)
- Grommet Cover Color

Notes

- Worksurface support hardware is specified separately.
- Rear corner grommet hole with cover is included.
- Additional grommet holes with covers are specified as options.

Shelf Surfaces and Rectangular / Radius Transactions

SHELF SURFACE				
D ¹	W ¹	Model Number	List	Grade C Laminate
12	24	W-CT1224	265	+17
12	30	W-CT1230	286	+18
12	36	W-CT1236	307	+19
12	42	W-CT1242	316	+20
12	48	W-CT1248	323	+21
12	54	W-CT1254	376	+24
12	60	W-CT1260	382	+24
12	66	W-CT1266	401	+27
12	72	W-CT1272	428	+27
12	78	W-CT1278	436	+28
12	84	W-CT1284	441	+28
12	90	W-CT1290	451	+29
12	96	W-CT1296	458	+29

RECTANGULAR TRANSACTION				
D ¹	W ¹	Model Number	List	Grade C Laminate
15	24	W-CT1524	279	+17
15	30	W-CT1530	303	+18
15	36	W-CT1536	320	+19
15	42	W-CT1542	331	+20
15	48	W-CT1548	344	+21
15	54	W-CT1554	394	+24
15	60	W-CT1560	398	+24
15	66	W-CT1566	448	+27
15	72	W-CT1572	448	+27
15	84	W-CT1584	465	+28
15	96	W-CT1596	480	+29

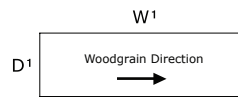
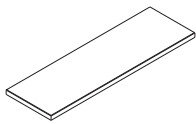

RADIUS TRANSACTION				
D ¹	W ¹	Model Number	List	Grade C Laminate
15	31.5	W-CT1524R	364	+17
15	37.5	W-CT1530R	385	+18
15	43.5	W-CT1536R	403	+19
15	49.5	W-CT1542R	421	+20
15	55.5	W-CT1548R	430	+21
15	61.5	W-CT1554R	477	+24
15	67.5	W-CT1560R	485	+24
15	73.5	W-CT1566R	533	+27
15	79.5	W-CT1572R	533	+27
15	91.5	W-CT1584R	548	+28

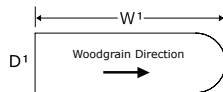

Specify

Notes

- Laminate Selection
- Color Selection for 2mm Edge

- Worksurface support hardware is specified separately.

GROMMET HOLE COVERS

Diameter	Model Number	List
3	W-GROMMET	37

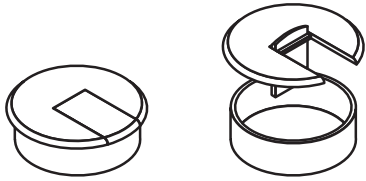

Specify	Notes
---------	-------

- | | |
|--|--|
| <ul style="list-style-type: none"> • Color Selection - White, Black or Grey Value 1 | <ul style="list-style-type: none"> • Grommet Hole Covers for cord management may be specified when ordering worksurfaces. • Grommet covers are included when worksurfaces are ordered with grommets. Order separately only if extra covers are required or if retrofitting grommets in the field. • Grommet holes required are 2 3/4" outside diameter with a 2 5/8" inside diameter (inside sleeve). • Available in White, Black or Grey Value 1. |
|--|--|



National Showrooms:

Leominster

AIS Headquarters
25 Tucker Drive
Leominster, MA 01453

Chicago

The Merchandise Mart
Suite 1086
Chicago, Illinois 60654

New York

AIS New York
257 Park Avenue South
New York, New York 10010

Washington, D.C.

AIS Washington, D.C.
1501 M St, NW, STE 230
Washington, D.C. 20005

GSA Sales

GSA Contract GS-29F-0006K
FSC Group 71,
Part 1 Office Furniture

For additional information on AIS:

Dealer Showrooms, Representative
Directory, Project Case Studies, Online
Catalog & Product Showcase
Visit: www.ais-inc.com